



W E S E

WAVE ENERGY
IN SOUTHERN EUROPE

DELIVERABLE 2.4 MONITORING OF SEAFLOOR INTEGRITY



This project has been funded by the European Commission under the European Maritime and Fisheries Fund (EMFF), Call for Proposals EASME/EMFF/2017/1.2.1.1 – “Environmental monitoring of wave and tidal devices”. This communication reflects only the author’s view. EASME is not responsible for any use that may be made of the information it contains.



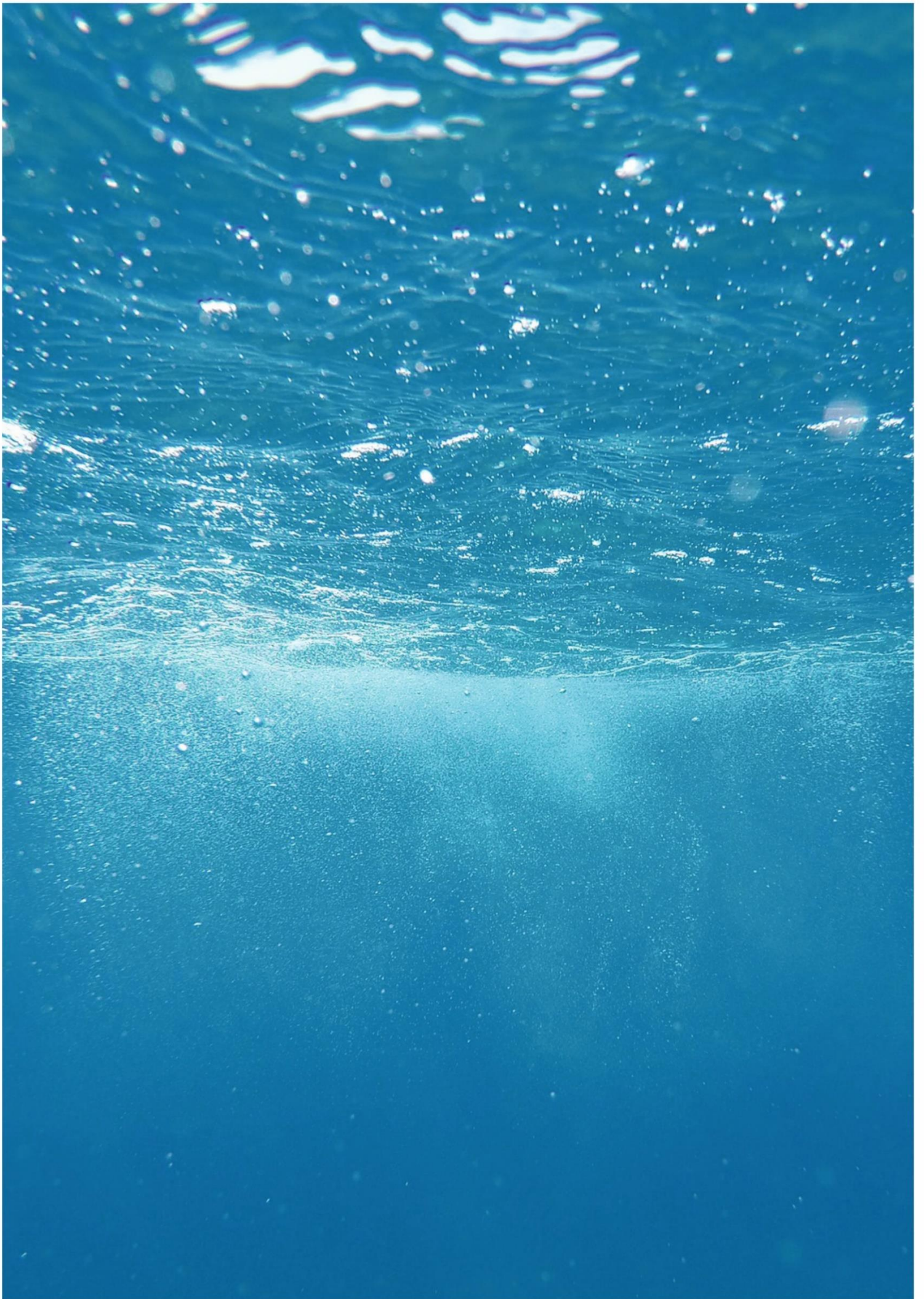

WP 2.4
Deliverable 2.4 Monitoring of seafloor integrity

PROJECT COORDINATOR
AZTI

TASK LEADER
AZTI

AUTHORS
Iñigo Muxika - AZTI
Pedro Vinagre - WavEC
Juan Bald - AZTI

SUBMISSION DATE
30 | November | 2020

CITATION

Muxika I., Vinagre P., and Bald, J., 2020. Deliverable 2.4 (Monitoring of seafloor integrity). Corporate deliverable of the WESE Project funded by the European Commission. Agreement number EASME/EMFF/2017/1.2.1.1/02/SI2.787640. 59 pp.

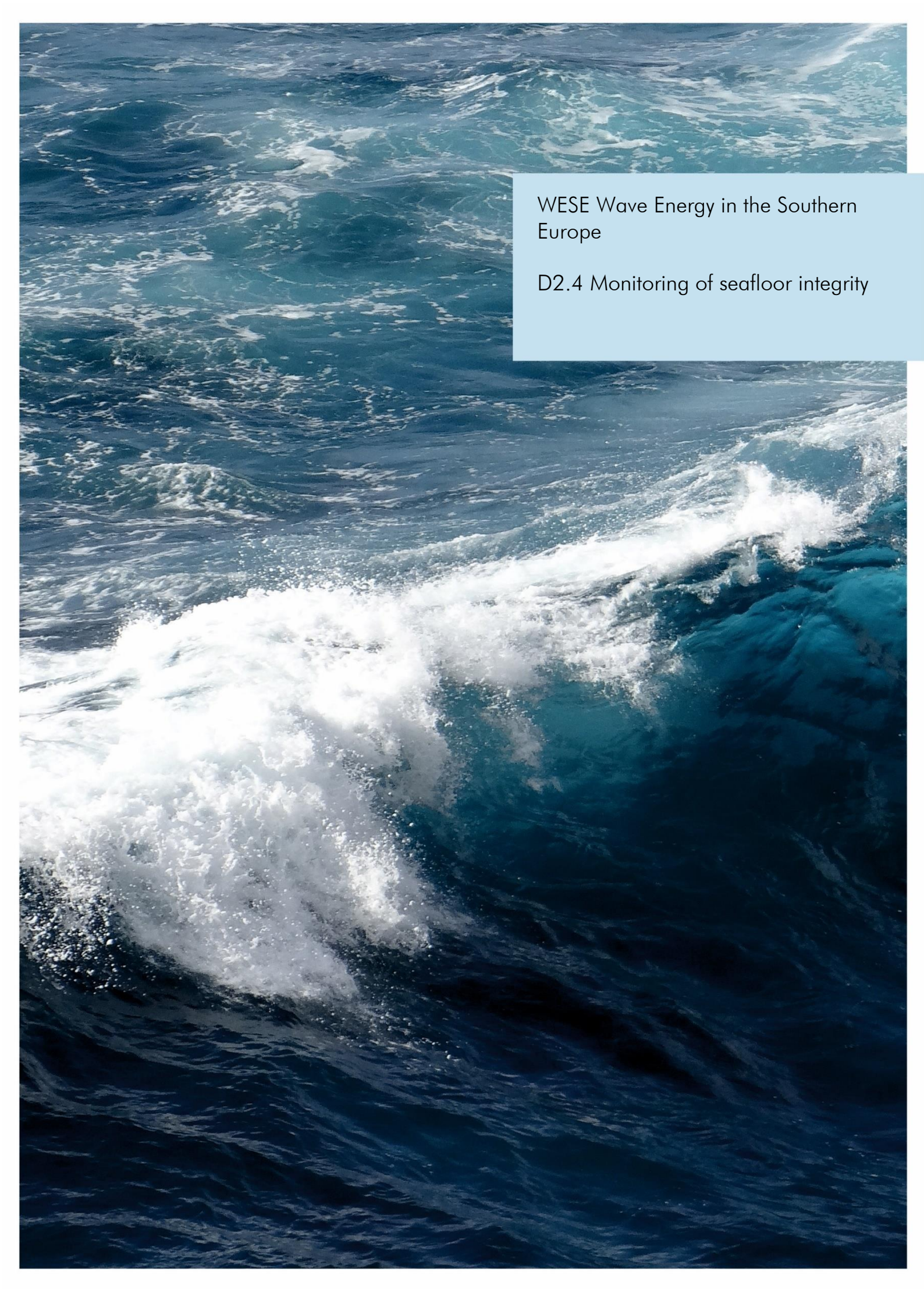

This project has been funded by the European Commission under the European Maritime and Fisheries Fund (EMFF), Call for Proposals EASME/EMFF/2017/1.2.1.1 – “Environmental monitoring of wave and tidal devices”. This communication reflects only the author’s view. EASME is not responsible for any use that may be made of the information it contains.

An aerial photograph of a boat's wake in the ocean. The water is a deep blue, and the wake is a bright white, frothy trail of water that curves from the bottom left towards the top right. The surrounding water has a textured, wavy appearance with small whitecaps.

WESE Wave Energy in the Southern
Europe

D2.4 Monitoring of seafloor integrity

CONTENTS

1. WESE PROJECT SYNOPSIS	0
2. EXECUTIVE SUMMARY	2
3. DESCRIPTION OF TEST SITES AND DEVICES	3
3.1 TEST SITES	3
3.1.1 <i>BiMEP</i>	3
3.1.2 <i>WaveRoller test site</i>	3
3.2 DEVICES	5
3.2.1 <i>MARMOK-A-5</i>	5
3.2.2 <i>WaveRoller</i>	5
4. SAMPLING DESIGN	7
4.1 MARMOK-A-5 MONITORING	7
4.1.1 <i>ROV</i>	7
4.1.2 <i>Side-scan SONAR</i>	9
4.2 WAVEROLLER MONITORING	13
5. FINDINGS OF THE SEAFLOOR INTEGRITY MONITORING	18
5.1 MARMOK-A-5 MONITORING	18
5.1.1 <i>ROV survey</i>	18
5.1.2 <i>Side-scan SONAR survey</i>	25
5.2 WAVEROLLER MONITORING	27
5.2.1 <i>ROV survey</i>	28
6. FUTURE WORK.....	36
7. ANNEXES	37



1. WESE project synopsis

The Atlantic seaboard offers a vast marine renewable energy (MRE) resource which is still far from being exploited. These resources include offshore wind, wave and tidal. This industrial activity holds considerable potential for enhancing the diversity of energy sources, reducing greenhouse gas emissions, and stimulating and diversifying the economies of coastal communities. Therefore, the ocean energy development is one of the main pillars of the EU Blue Growth strategy. While the technological development of devices is growing fast, their potential environmental effects are not well-known. In a new industry like MRE, and Wave Energy (WE) in particular, there may be interactions between devices and marine organisms or habitats that regulators or stakeholders perceive as risky. In many instances, this perception of risk is due to the high degree of uncertainty that results from a paucity of data collected in the ocean. However, the possibility of real risk to marine organisms or habitats cannot be ignored; the lack of data continues to confound our ability to differentiate between real and perceived risks. Due to the present and future demand for marine resources and space, human activities in the marine environment are expected to increase, which will produce higher pressures on marine ecosystems; as well as competition and conflicts among marine users. This context still continues to present challenges to permitting/consenting of commercial-scale development. Time-consuming procedures linked to uncertainty about project environmental impacts, the need to consult with numerous stakeholders and potential conflicts with other marine users appear to be the main obstacles to consenting WE projects. These are considered as non-technological barriers that could hinder the future development of WE in EU and Spain and Portugal in particular were, for instance, consenting approaches remain fragmented and sequential. Consequently, and in accordance with the Ocean Energy Strategic Roadmap published in November 2016¹, the main aim of the project consists on overcoming these non-technological barriers through the following specific objectives:

- Development of environmental monitoring around wave energy converters (WECs) operating at sea, to analyse, share and improve the knowledge of the positive and negative environmental pressures and impacts of these technologies and consequently a better knowledge of real risks.
- The resulting data collection will be used to apply and improve existing modelling tools and contribute to the overall understanding of potential cumulative pressures and impacts of larger scale, and future, wave energy deployments.

- Development of efficient guidance for planning and consenting procedures in Spain and Portugal for WE projects, to better inform decision-makers and managers on environmental real risks and reduce environmental consenting uncertainty of ocean WE introducing the Risk Based Approach suggested by the RiCORE, a Horizon 2020 project, which underline the difficulties for developers with an existing fragmented and sequential consenting approaches in these countries;
- Development and implementation of innovative maritime spatial planning (MSP) Decision Support Tools (DSTs) for Portugal and Spain for site selection of WE projects. The final objective of such tools will be the identification and selection of suitable areas for WE development, as well as to support decision makers and developers during the licensing process. These DSTs will consider previous findings (both environmental and legal, found in RiCORE) and the new knowledge acquired in WESE in order to support the development of the risk-based approach mentioned in iii);
- Development of a Data Sharing Platform that will serve data providers, developers and regulators. This includes the partners of the project. WESE Data Platform will be made of a number of ICT services in order to have: (i) a single web access point to relevant data (either produced within the project or by others); (ii) Generation of OGC compliant requests to access data via command line (advanced users); (iii) a dedicated cloud server to store frequently used data or data that may not fit in existing Data Portals; (iv) synchronized biological data and environmental parameters in order to feed models automatically.

2. Executive summary

As summarized in the Deliverable 2.1 (Vinagre *et al.*, 2019)¹, the Work Package 2 of the WESE project aims to collect, process, analyse and share the environmental data in three areas affected by different types of wave energy projects, i.e.: (1) oscillating water column device deployed offshore – MARMOK-A-5 developed by IDOM – in the Biscay Marine Energy Platform test site (BiMEP) located in Armintza (Spain); (2) oscillating wave surge converter deployed nearshore – WaveRoller developed by AW-Energy – in Peniche (Portugal); and (3) water turbine converter deployed onshore – Mutriku Wave Power Plant – in Mutriku (Spain).

The Deliverable 2.1 represented the first phase for the fulfilment of the objectives above, which is the planification of the monitoring plans for noise, electromagnetic fields (EMF) and seafloor integrity for the projects mentioned.

The Deliverables 2.2, 2.3 and 2.4 are focused on the results obtained from the monitoring plans executed for EMF, noise, and seafloor integrity, respectively. For the particular case of seafloor integrity, it should be noticed that, from the devices above, the Mutriku Wave Power Plant operates in a breakwater, on artificial substrata, whereas both MARMOK-A-5 and WaveRoller were installed on natural seafloor. Hence, the main aim of the present Deliverable is to describe the main findings of the environmental effects coming from the latter two devices mentioned.

¹ Vinagre P.A., Cruz E., Chainho P., Ruiz P., Felis I., Muxika I., Bald J., 2019. Deliverable 2.1 Monitoring plans for Noise, Electromagnetic Fields and Seabed Integrity. Corporate deliverable of the Wave Energy in the Southern Europe (WESE) Project funded by the European Commission. Agreement number EASME/EMFF/2017/1.2.1.1/02/SI2.787640. 64 pp.

3. Description of test sites and devices

3.1 Test sites

3.1.1 BiMEP

The Biscay Marine Energy Platform (BiMEP, www.bimep.com) is an open-sea facility to support research, technical testing and commercial demonstration of pre-commercial prototype utility-scale floating Marine Renewable Energy Devices (MREDs). BiMEP provides manufacturers of such devices with ready-to-use facilities to validate their designs and to test their technical and economic feasibility.

BiMEP occupies a 5.3 km² marked area excluded from navigation and maritime traffic. It is located at a minimum distance of 1,700 m from shore, close enough for fast access to deployed devices. The water depth in this area ranges from 50 m to 90 m. The total power of 20 MW is distributed over four offshore connection points of 5 MW each (Figure 1).

Each berth is connected to the onshore substation via a dedicated three-phase submarine cable in series with a land three-phase line, both at 13.2 kV. The onshore electricity substation houses electrical protection systems, measurement systems and transformer, allowing the berths to be connected to the national power grid. The berths are fitted with commercial power and fibre optic connectors to enable swift connection and disconnection of MREDs.

Until recently, BiMEP hosted the first floating wave energy device connected to the grid in Spain, the MARMOK-A-5 device, developed by IDOM-Oceantec.

3.1.2 WaveRoller test site

The concession area of the WaveRoller is located in a mostly sandy bottom of the Almagreira beach in the Peniche municipality (West Coast of Portugal). It is included in the Site of Community Importance (SCI) Peniche/Santa Cruz (PTCON0056) defined in the EC Habitats Directive (HD, 1992) of Rede Natura 2000.

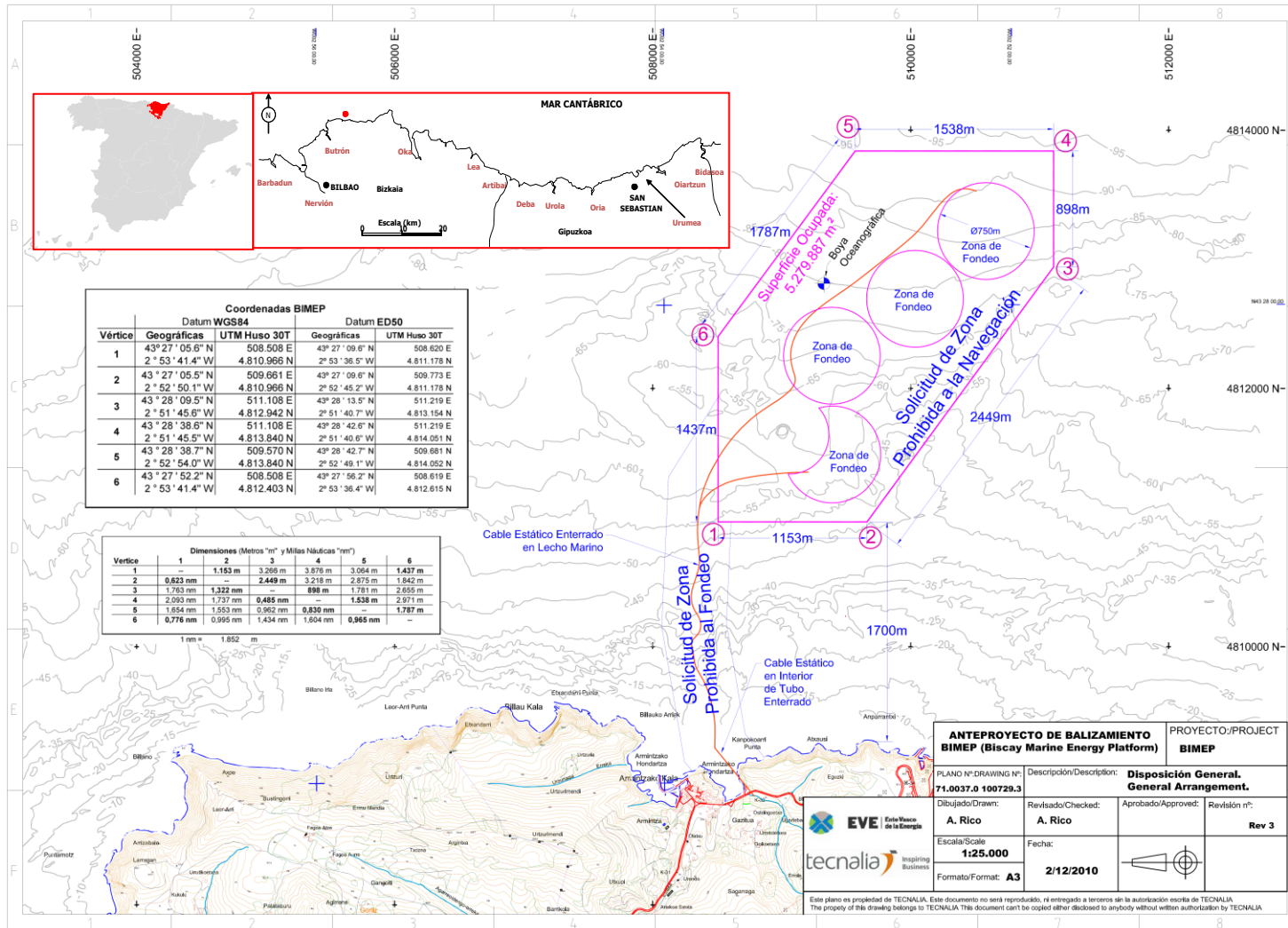

Figure 1. General arrangement of BIMEP.

3.2 Devices

3.2.1 MARMOK-A-5

The MARMOK-A-5, developed by IDOM-Oceantec, is a low power device prototype based on the oscillating water column (OWC) working principle, with a point absorber configuration.

The device is typically known as SPAR BUOY OWC. It consists of a simple and robust buoy that moves by the action of the waves and is composed of three parts: a float that moves by the effect of waves, a hollow cylinder that contains the water column and a last lower element that provides stability and inertia. The size of the OWC is 42 m length and 5 m diameter, with a capacity of 30 kW (Figure 2).

The MARMOK-A-5 was deployed in BiMEP (43°28'9.52"N, 2°52'11.42"W) in October 2016 at a depth of 80 m and moored to the seafloor trough 4 mooring lines. It was decommissioned in July 2019.



Figure 2. MARMOK-A-5 device deployed at BiMEP (By Oceantec - Own work, CC BY-SA 4.0, <https://commons.wikimedia.org/w/index.php?curid=59387399>).

3.2.2 WaveRoller

The WaveRoller system was developed by AW-Energy (<https://aw-energy.com/waveroller>). The WaveRoller unit (Figure 3) is mounted on a large concrete foundation 42 m long and 18 m wide and consists of an oscillating bottom hinged WEC with a steel flap 18 m wide and 10 m high, representing a total area of 860 m² of which 756 m² integrate the maritime public domain.

The WaveRoller unit was deployed in the end of October 2019, positioned at about 850 m of the shoreline ($39^{\circ}23.374'N$, $9^{\circ}18.500'W$) between the -15 m and the -20 m bathymetries. It was to be removed from water for maintenance in October 2020; however, the foundation and WEC were in the same day (October 17th) lifted from the seafloor and again set in place, and the decommissioning was cancelled.

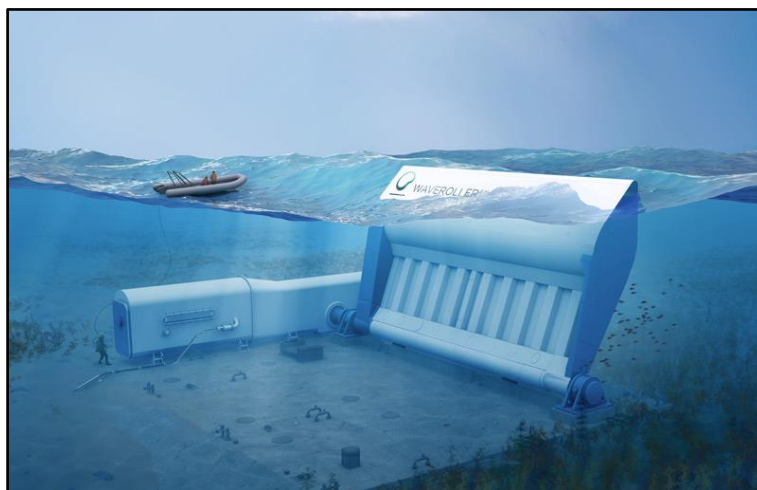

Figure 3. Representation of the WaveRoller unit. Source: AW-Energy (<https://aw-energy.com/waveroller>).

4. Sampling design

Non-destructive methods were used for seafloor monitoring both in BiMEP and in Peniche. A ROV was used to record videos of the seafloor in the vicinities of the MARMOK-A-5 moorings and chains (and also of the electric cable and the connector), and at the WaveRoller area including the foundation, the electrical cable, and mooring cables.

The video recordings were then analysed with the aim of describing the main effects on seafloor integrity in quality, but also quantitatively or, at least, semi-quantitatively. For that, alterations over the bottom structures (e.g., ripples) were described and the approximate affected area was calculated. The attraction of fishes and invertebrates by the moorings was also considered.

In the BiMEP area, a side-scan SONAR survey was also undertaken to look for changes in the reflectivity of the seafloor close to the moorings. This would provide information on the seafloor integrity beyond the visual changes observed in the video recordings, such as changes in the degree of compaction of the sediment.

4.1 MARMOK-A-5 monitoring

4.1.1 ROV

In BiMEP, a SEAEYE Falcon DR ROV, equipped with two video cameras, was employed (Figure 4). An onboard camera was used for navigation and a full HD camera with a resolution of 1920×1080 px at a $16 \text{ Mbit}\cdot\text{s}^{-1}$ was used for the video shots. It was also equipped with a SONAR system to scan the surroundings of the ROV looking for outcrops. The SONAR was used to locate the anchors and the connector.



Figure 4. SEAEYE Falcon DR ROV employed in the seafloor monitoring in BiMEP. On the left, all the equipment on board the vessel. On the right, the ROV ready to be deployed in the sea.

The four mooring lines and anchors of the device were recorded between the area the chains landed on the bottom and the area the anchors were settled. The operation was repeated for the electric cable and the connector that provide service to the MARMOK-A-5 device. The mooring scheme of the device is represented in Figure 5.

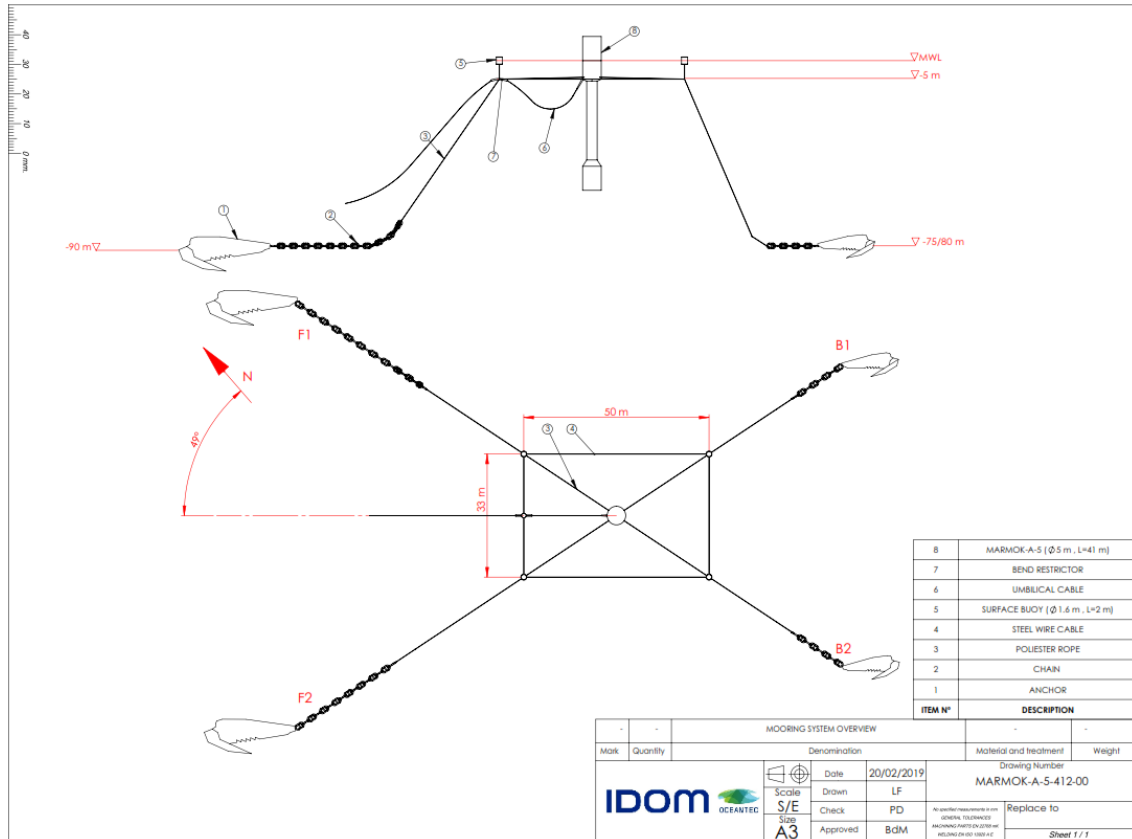

Figure 5. Mooring scheme for the MARMOK-A-5 device deployed in BiMEP.

Several problems were experienced during the survey, hence it lasted two days to complete the inspection. On May 15th, 2019, the ROV was deployed to look for the F2 anchor. However, it experienced problems with the SONAR. Hence, the ROV was navigated to the surface buoys to follow the moorings from surface to the bottom, and then, from the landing area to the anchor. This operation was undertaken satisfactorily for the B2 mooring. On the contrary, the F1 and F2 mooring lines, and the umbilical cable were not recorded as they were too long, and the ocean and weather conditions were not ideal. The F2 mooring was recorded from surface to the landing area only. The B1 mooring was not recorded either as the adverse ocean and weather conditions made the operation risky.

On May 22nd, 2019, a new SONAR was installed in the ROV and it was used to locate the B1 and F1 anchors and the connector between the umbilical cable of the

MARMOK-A-5 device. The export cable to land, the anchors, moorings, connector, and umbilical cable were recorded.

During the operations, the wind blew from the north at a speed of approximately $5 \text{ km}\cdot\text{h}^{-1}$. The waves were 0.5 m high.

4.1.2 Side-scan SONAR

Besides the ROV campaign, another survey was carried out in BiMEP with a side-scan SONAR. A GeoAcoustics 100/410 kHz profiler was employed to cover the area around the moorings, mooring lines and cables providing service to the MARMOK-A-5 device. The position of the SONAR was examined by a GPS TRIMBLE 850 SPS connected to an ultra-short baseline (USBL) transponder and a laptop with HYPACK2017 software. Detail of the system and data acquisition are shown in Figure 6 to 13.

The side-scan SONAR survey was completed on May 14th, 2019. A total of 18 lines were carried out, covering a total distance of 15.75 km (Figure 14).

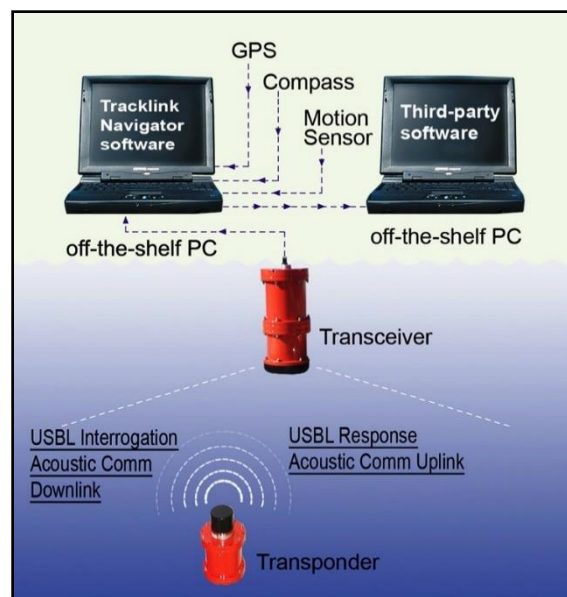

Figure 6. Functional diagram of the USBL system.



Figure 7. USBL System.



Figure 8. USBL bar mounted transducer to be installed on the band.



Figure 9. Mounting on the band of the USBL, gyro and GPS.



Figure 10. GeoAcoustics 100/500 kHz side-scan SONAR, including a GeoAcoustics transmitter-receiver unit and an underwater location pinger.



Figure 11. Side-scan SONAR winch and towing cable.

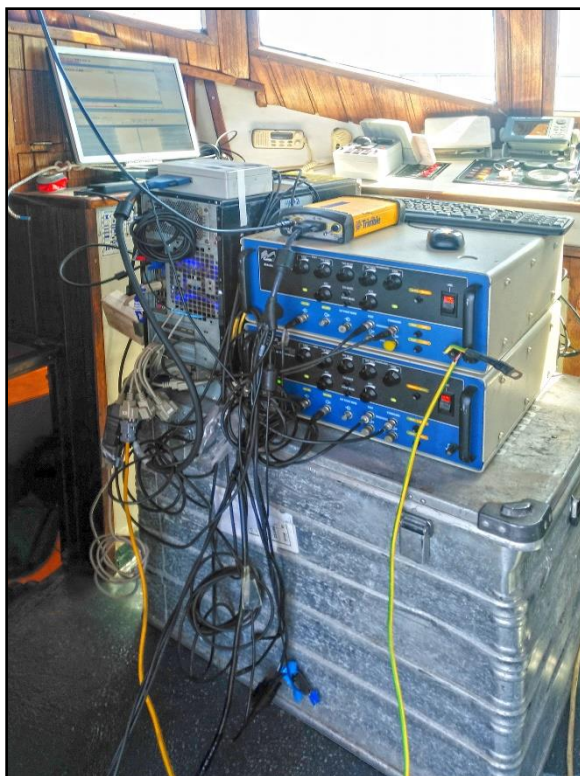

Figure 12. Side-scan SONAR data acquisition system and position.

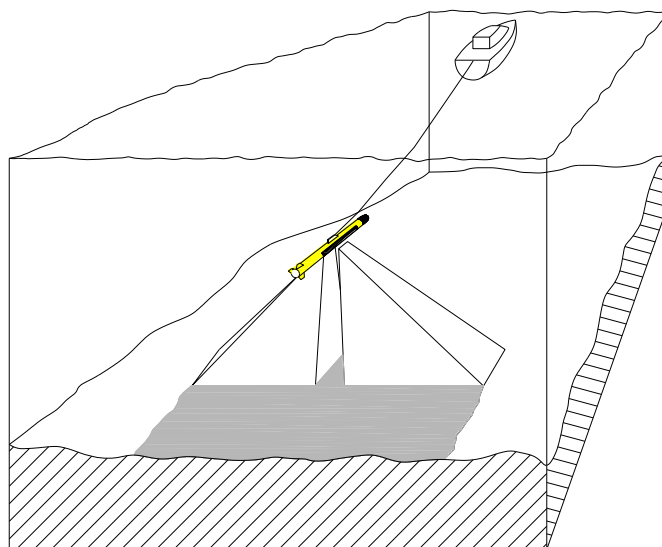

Figure 13. Data acquisition with side-scan SONAR.

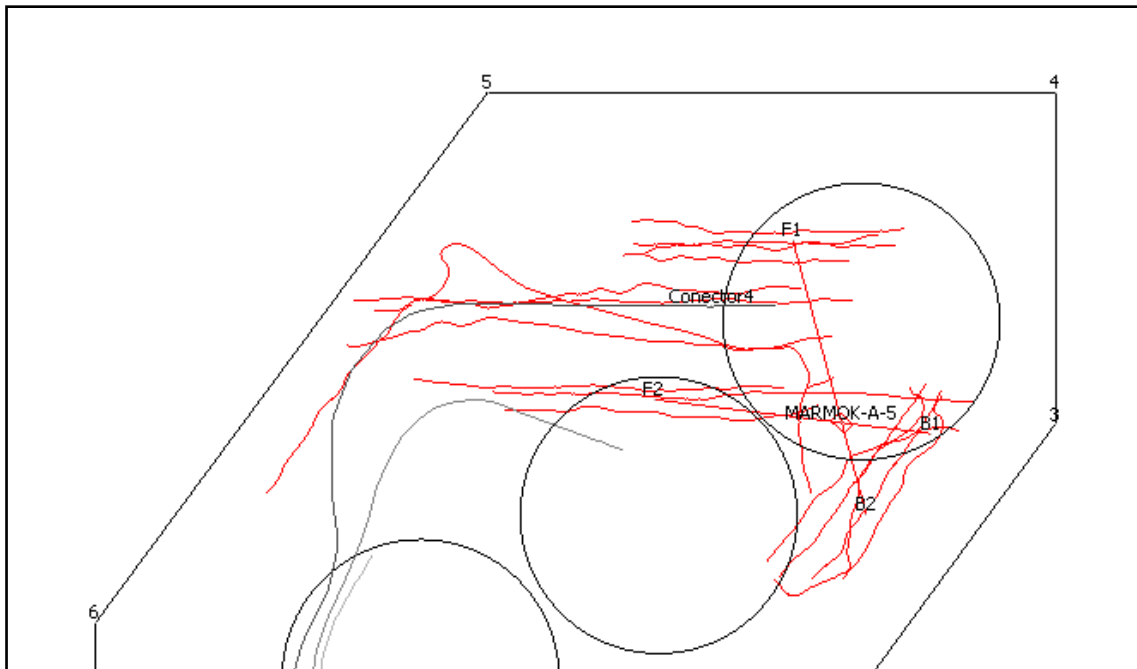

Figure 14. Map of itineraries (in red).

However, the wave height of 1.5-2 m prevented the collection of adequate data: due to the risk of entanglement with the mooring lines, the transducer was towed at a greater distance from the seafloor than the distance planned; moreover, the waves pulled the transducer, consequently introducing artefacts in the data acquisition, especially in the band of high frequency of 500 kHz (Figure 15).

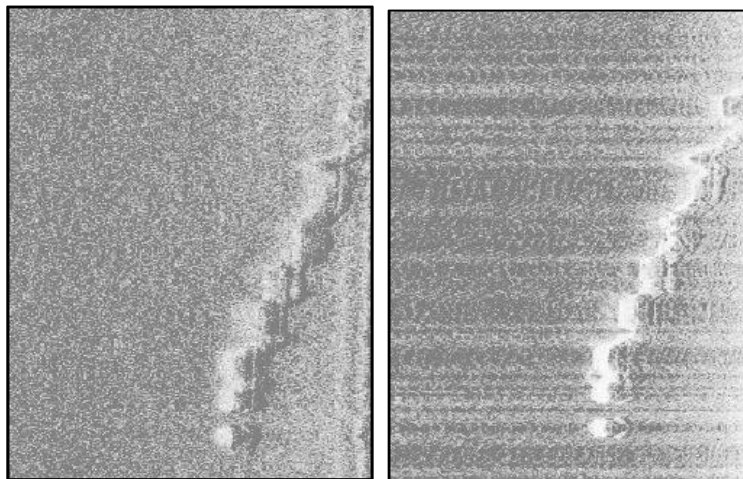

Figure 15. Records in the same area of 100 kHz (left) and 500 kHz (right). Note that the effect of the swell (tugs) is more pronounced at the 500 kHz register.

4.2 WaveRoller monitoring

In Peniche, a Seabotix LBV200-4 ROV equipped with two video cameras was employed (Figure 16 and 17). An onboard camera was used for navigation and a HD

GoPro 4 with a resolution of 1080p was used for video shots. The ROV includes a laser scaling system (two red laser dots 5 cm apart) to allow scaling objects.



Figure 16. WavEC's ROV setup and team at the WaveRoller test site.

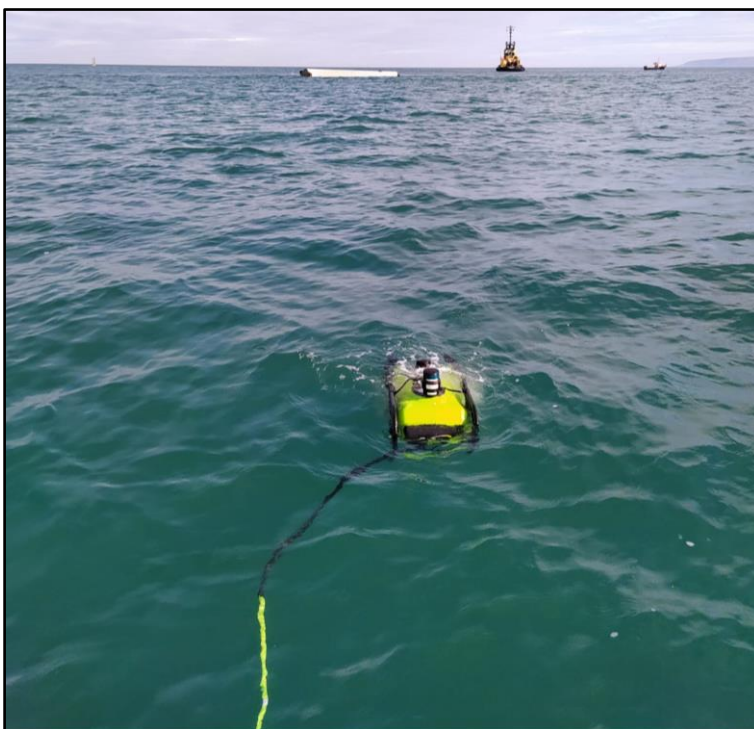

Figure 17. WavEC's ROV moving towards the WaveRoller device (emerged section visible in the background).

Some issues were experienced and changes to the monitoring plan defined in deliverable 2.1 were necessary, namely:

- i) The WaveRoller unit was deployed at the end of October 2019. To allow minimal time for potential changes in the seafloor to be observed one monitoring campaign would be performed during the spring-summer period of 2020.

Owed to different constraints (ROV repairing delayed by COVID-19 issues; difficulty in finding the most adequate sea conditions and simultaneously in finding adequate vessels available owed to touristic activities), the monitoring was performed on October 17th, 2020.

- ii) The monitoring would be performed along 7 transects (of 100 m), 6 transects in the adjacent areas of the WaveRoller device and 1 transect along the submarine cable (Figure 18).

Because the WaveRoller was expected to be removed from water for maintenance, it was meanwhile discussed during the project meetings (after the development of Deliverable D2.1) to perform two monitoring campaigns instead of one, one campaign before removal and one campaign after it, reducing the number of transects to 3 transects per campaign. This would allow better understanding of impacts from WaveRoller by comparing before and after effects. During the campaign of October 17th, the sea conditions allowed to perform 5 transects (hereafter named WR_T1 to WR_T5) instead of 3 (Figure 19). The coordinates of the transects (Table 1) did not match those set in D2.1 (see section iv). The second campaign has not yet been performed as the WaveRoller has not been removed from water.

- iii) The transects would be monitored with a fixed heading and at a speed as constant as possible and below $0.25 \text{ m}\cdot\text{s}^{-1}$ (= 0.5 knots) to avoid image blurring.

Monitoring was done following a fixed heading whenever possible. Fixed heading was not considered when areas of relevant interest were found, the monitoring being carried out around those areas. These included the moorings, the foundation, the electrical cable, sandy and rocky substrates, rocky outcrops, and biogenic reefs. Because the test site is located nearshore in a highly hydrodynamic area with inherent strong bottom currents and turbulence, it was very difficult to operate the ROV. This contributed to not being possible to maintain fixed headings and to keep low, constant speed.

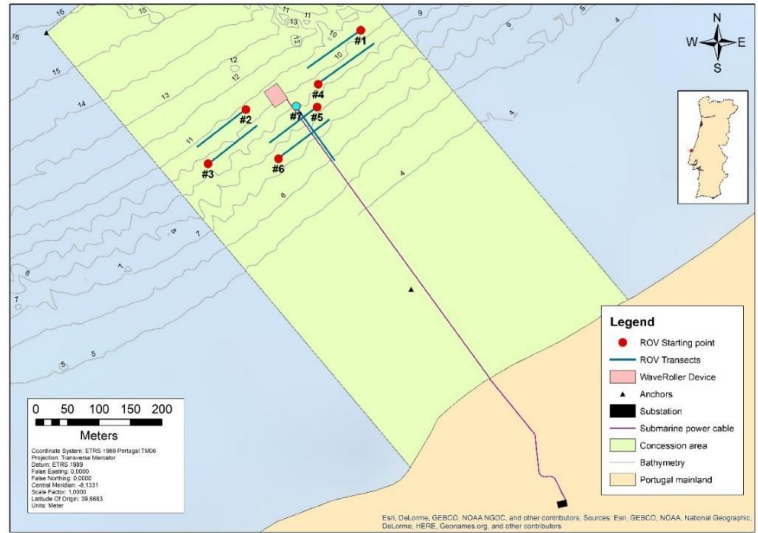

Figure 18. ROV sampling stations at the WaveRoller area as defined in Deliverable 2.1.

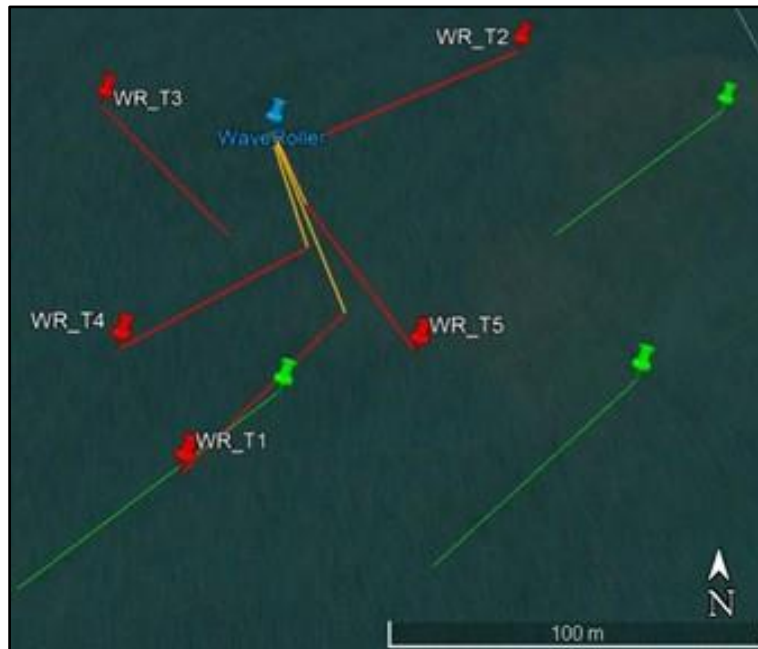

Figure 19. ROV sampling stations at the WaveRoller test site. Key: WR_T1 to WR_T5 are the five transects surveyed: the red colour indicates the intended heading, and the red plus orange colours represent the area surveyed; In green are the three transects aimed as discussed in meetings after the development of Deliverable D2.1. Base map: Google Earth.

Table 1. Geographic coordinates (degrees decimal minutes) of each transect (WR_T1 to WR_T5) starting point at the WaveRoller test site.

Sampling stations ID	Latitude (°)	Longitude (°)
WR_T1	39°23.296' N	9°18.526' W
WR_T2	39°23.399' N	9°18.428' W
WR_T3	39°23.382' N	9°18.544' W
WR_T4	39°23.320' N	9°18.539' W
WR_T5	39°23.319' N	9°18.473' W

- iv) Adequate sea conditions would be assured for the sampling campaigns, both in terms of wave height and visibility and concerning to the safety of workers.

Monitoring was conducted in a fairly calm, sunny to slightly cloudy day. Nonetheless, during the monitoring campaign wave height and wind speed started increasing (WindGuru forecast of 1.4 m wave height and 13-16 knots wind speed/gusts; www.windguru.cz), making it necessary to frequent re-positioning and anchoring of the vessel (Figure 20) especially during WR_T3, WR_T4 and WR_T5. The wave and wind conditions further increased the difficulty in operating the ROV because of the great drag on the umbilical cable.

- v) The team has experienced the unexpected malfunction of the USBL system, which would allow to register and track the exact location of the ROV underwater and, consequently, allow to register the exact location of anything captured in the videos.

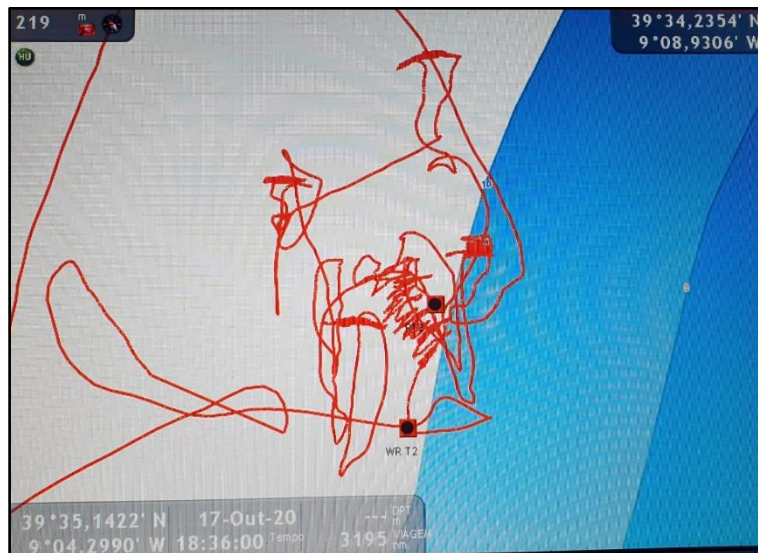

Figure 20. Vessel repositioning (red line) during the seafloor integrity monitoring at the WaveRoller area.

5. Findings of the seafloor integrity monitoring

5.1 MARMOK-A-5 monitoring

5.1.1 ROV survey

This section describes the findings from the monitoring of each mooring, the umbilical cable and the connector (see the ROV dive logs in Annex 1). The information on the videos recorded will be included in the WESE project MARENDATA portal (<http://marendata.eu>).

The video recordings show that three years after the installation of the device, in June 2016, there is not any evidence of recent movements of the anchors causing physical disturbance in the area (Figure 21). Actually, the ripple marks in the area are not altered either in the closest vicinity to the anchors.



Figure 21. Ripple marks close to the B2 anchor.

However, in a bathymetric survey carried out in September 2017, footprints apparently caused by the anchors could be seen (Figure 22). The footprints caused by the anchoring of anchors B1 and B2, which are close to the outcrops, are nearly 8 m in radius, whereas the footprints caused by F1 and F2 are roughly 12 m. The anchoring was carried out in June 2016, what may indicate that the disturbance caused in the process was still visible one year after. On the contrary, three years after the anchoring, the video recordings do not show such an alteration of the seafloor even with the energy convertor in operation.

Despite the above mentioned, the anchors may be working as fish and invertebrate attractors as shoals of poutings (*Trisopterus luscus*) have been recorded swimming around them (Figure 23). European congers (*Conger conger*) were also recorded hidden by the anchor (Figure 24). Finally, an European lobster (*Homarus gammarus*) seeking for protection by the B2 anchor was also captured by the video (Figure 25).



Figure 22. Footprints (inside the red circles) probably caused by the anchoring operation in a bathymetry obtained in September 2017 (the anchoring was carried out in June 2016).



Figure 23. Shoal of putings (*Trisopterus luscus*) in the vicinity of F1 anchor.



Figure 24. Specimen of European conger (*Conger conger*) sheltered below the anchor.



Figure 25. European lobster (*Homarus gammarus*) seeking for protection under the B2 anchor.

As described for the anchors, the connector is also partially buried into the sediment, not showing any indication of recent movements and physic alteration of the sediment. Furthermore, alike the anchors, the connector seems to be acting as a fish attractor, as a shoal of poutings was swimming around it and an European conger was resting on it (Figure 26).

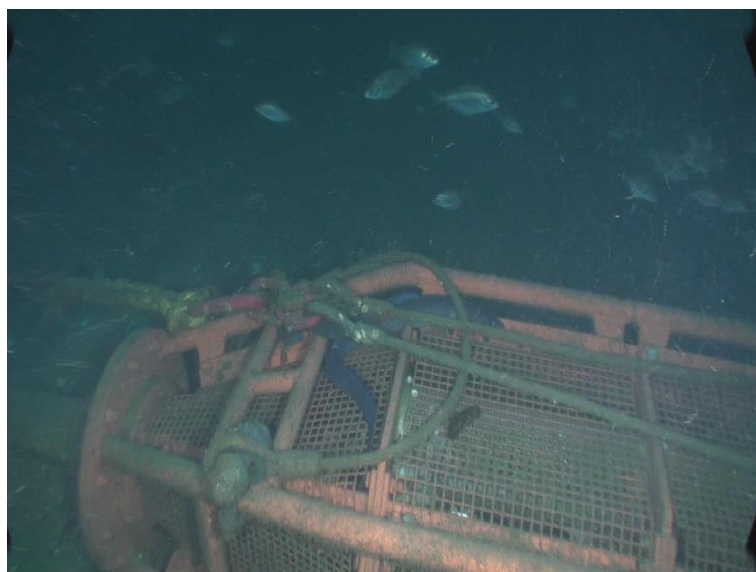

Figure 26. A shoal of poutings (*Trisopterus luscus*) around the connector and at least one European conger (*Conger conger*) on the connector.

However, the attraction effect of the anchors and the connector will probably not be significant due to the small size and number of them relative to the total area of the concession.

The only singularity found in the recordings close to the anchors is a sediment mound covered by mussel shells (*Mytilus edulis*) in the vicinity of B2 anchor (Figure 27). Over them, there were also starfishes (*Marthasterias glacialis*). Pieces of ropes and chains

lied into the sediment of the mound, which may indicate that it was an accumulation of sediment covering spores of them, over which mussels had grown. However, the anchor was close to rocky beds (in the eastern side of BiMEP). Hence, the mound could also correspond to an outcrop covered by sediment. Therefore, it cannot be concluded whether it was caused by rope sections with *M. edulis* fallen from the installation and accumulated on the seafloor or whether it corresponded to an outcrop close to rocky beds.



Figure 27. Sediment mound with mussel shells (*Mytilus edulis*) near B1 anchor. Some starfishes (*Marthasterias glacialis*) can be observed probably preying on the mussels.

Regarding the moorings, the first sections of the chains move on a stripe of up to roughly 2.5 m width at both sides (Figure 28). These sections cover a length of 15-20 m from the point where the chains reach the bottom. Along these stripes, the smoothing effect of the chains is evidenced by the total or partial remotion of ripple marks in the area (Figure 29). After those 15-20 m the chains lie on the ripple marks, buried by the crests (Figure 30) and physical alterations are not observed.

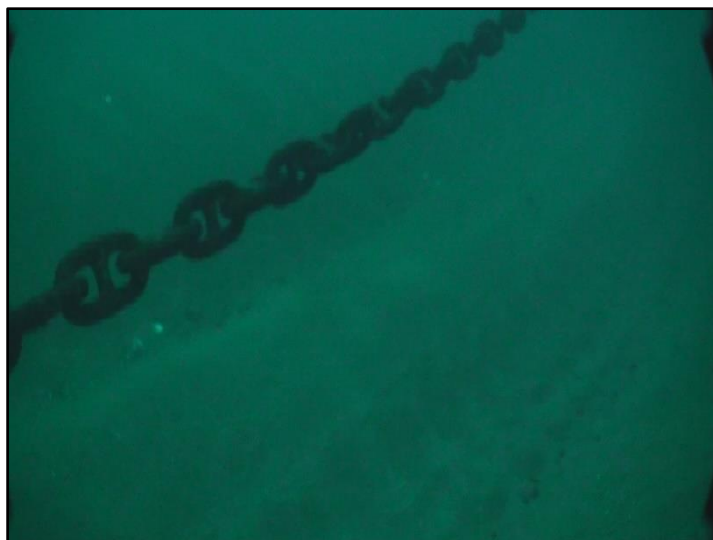

Figure 28. Sediment disturbed by the movement of the chains in B2 (up) and tracks made by the chain after it raises from the sediment (below).

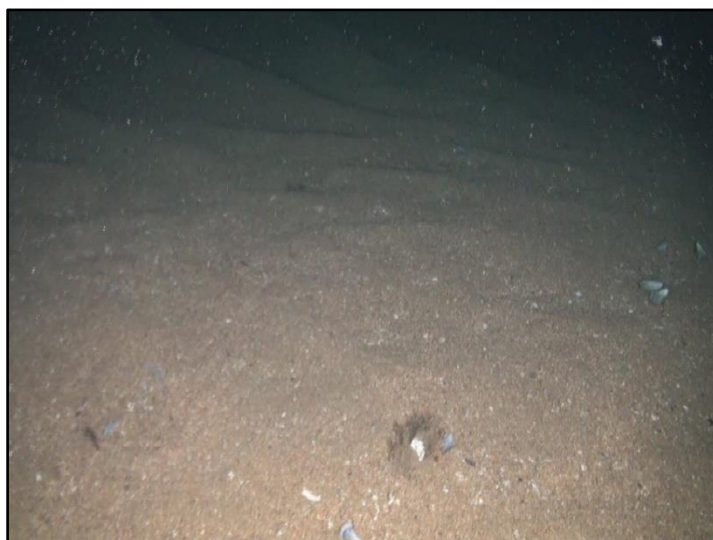

Figure 29. In the background, ripple marks on the sediment. In the foreground, they have been partially removed due to the movement of the chain.

Assuming a triangular shape of altered seafloor, with a maximum width of 5 m (each side of the chains with 2.5 m) and a length of 20 m, it could be estimated that the area affected for each chain is roughly 50 m².

Similarly, the umbilical cable that transports the electricity from the converter to the connector also moves horizontally in the area close to the landing point. However, the area affected by such movement goes beyond the visual field of the video camera and could not be estimated (Figure 31). At nearly 10 m from the point the cable reaches the sea bottom and turns approximately 90°. At one of the sides of the wire some

footprints can be appreciated as lines that run parallel to it (Figure 32), indicating that the cable moves over a stripe of roughly 5-10 m width.



Figure 30. Chain from B1 anchor partially buried into the ripple marks.

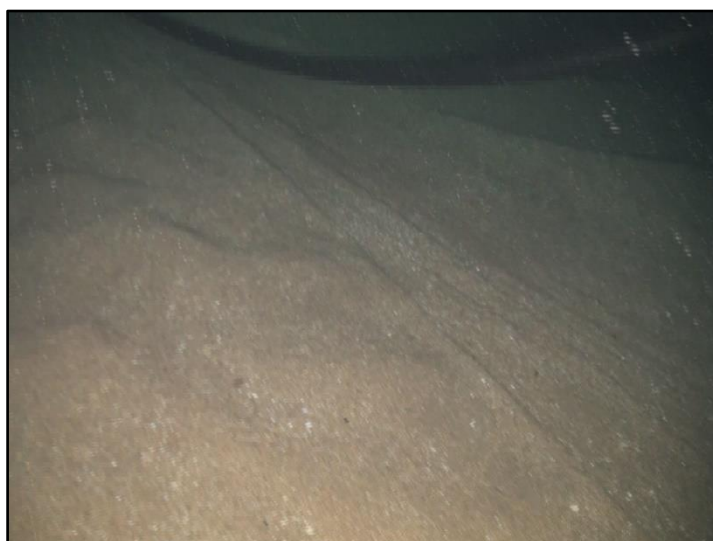

Figure 31. Footprints made by the cable on its vertical oscillation and altered ripple marks at the side.

After that turn, the cable runs almost perpendicular to the ripple marks and parallel to a rope, buried by their crests (Figure 33), until it reaches the connector.

Although the width of the stripe caused by the movement of the cable could not be measured, from the footprints observed in the abovementioned turn, it could be estimated that it moves in a band of a minimum width of 5-10 m, along the first 10 m from the landing point of the cable. Hence, it can be estimated that the affected area could reach at least 50-100 m².



Figure 32. The wire turns roughly 90°. Some footprints at the side of the wire indicate different lines the wire has been placed previously.



Figure 33. Rope and wire to connector lying on the ripple marks, buried by the crests.

In summary, considering the chains of the four mooring lines and the cable from the convertor to the connector, it can be estimated that the area affected by the sections that are moving over the sediment could add up to roughly 250-300 m². Considering that the total area occupied by the device (polygon bounded by the four anchors and the connector) is approximately 290.000 m², the affection area estimated relative to the total occupied area is 0.1%.

5.1.2 Side-scan SONAR survey

This section describes the findings from the monitoring of transects analysed using the side-scan SONAR (see the dive logs in Annex 2).

Regarding the side-scan SONAR survey, as indicated in section 4.1, the acquired data does not give a clear image of the seafloor and consequently it was not possible to collect data useful for the analysis of the impact associated to the anchors, mooring lines and umbilical cable. Hence, the assessment based on video recordings using the ROV could not be compared with the assessment using acoustic methods.

After processing the data obtained during the campaign, the side-scan sonar records were analysed in order to determine the position of the anchorages and mooring lines that anchor the MARMOK-A-5 converter to the bottom. The records have also been analysed along the initial route of the cable and connector to the marine infrastructure, detecting buried and unburied sections observed in the sonographic mosaic.

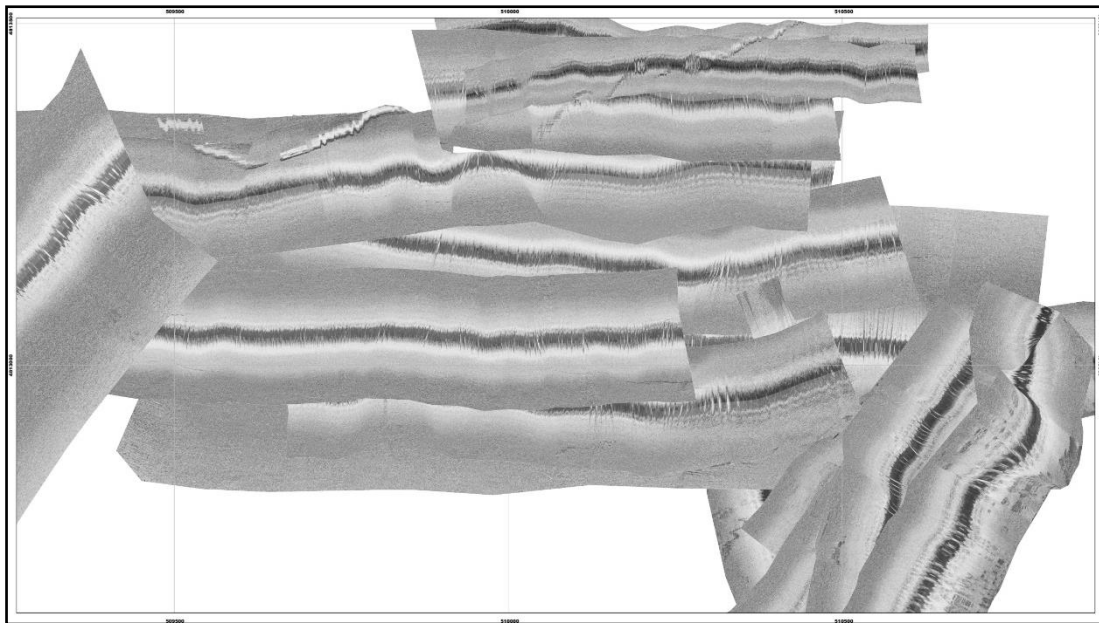

Figure 34. Sonographic mosaic (100 kHz).

In general, the study area is mainly made up of sand bottoms with SSO-NNE crest direction ripples (Figure 35). Scattered rocky outcrops have also been observed, more abundant towards the southeast of the WEC location area and towards the northern edge of the cable route.



Figure 35. Sonar record (100kHz) with rocky outcrops (top) and sand with ripples (bottom).

Along the route of the cable, it is dug out in an E-W direction from the connection point to the turning point towards the south. The connector has been identified at point 510157, 4813248. The cable runs from the connector towards the SE, burying itself until it disappears (Figure 36 and Figure 37).



Figure 36. Sonar record (100kHz) where the unearched cable can be seen on a sandy bottom.

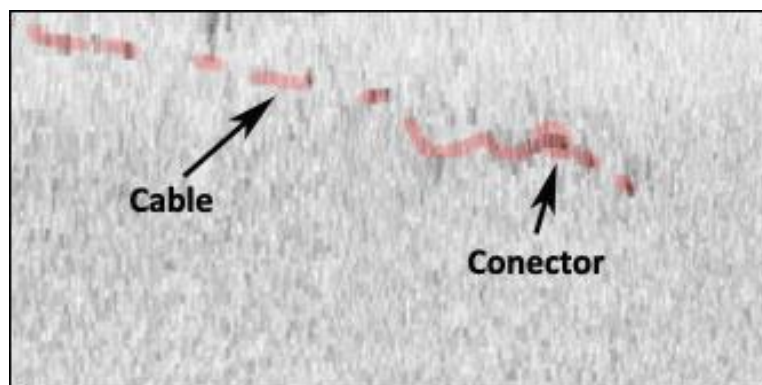

Figure 37. Sonar log (100kHz) with cable and connector detail.

With regard to the mooring lines, sections of unearched lines have been observed on the bottom, determining their position. The unearched sections correspond to the F2-

B1 anchorage line, which runs in an WNW-ESE direction, from F2 to the sensor and then from the sensor to B1.

The fact that the mooring lines and cable route oriented in an E-W direction appear unburied as opposed to those oriented in a NW-SSE direction, which have not been identified in the register and which we therefore think are buried, may be due to the burial effect derived from the migration of bed forms (ripples). In terms of the direction of the ridges (SSW-NNE), these will migrate in a NW-SE direction, favouring the burial of lines aligned in transversal directions to the direction of migration.

Along the mooring lines and mooring points there are no features which could be interpreted as possible effects derived from their installation and permanence: dragging marks by claws or terminals, scour, deposits, or alterations in the local hydrodynamics.

In any, case, as stated before, the images are not sufficient clear in order to have a clean vision of these possible impacts.

5.2 WaveRoller monitoring

This section describes the findings from the monitoring of each transect (see the ROV dive logs in Annex 3). The metadata corresponding to such videos will be uploaded to the WESE project MARENDATA portal (<http://marendata.eu>), including the bookmarks to any specific object or area of interest. That includes, for each transect, one video recorded with the onboard camera (lower resolution, but information such as the time of the day and depth and temperature at each second) and one video record with a GoPro.

The readers are advised to check the videos of both cameras: since the two cameras are positioned in different sections of the ROV (onboard: front section; GoPro: bottom left section), they capture different perspectives and sometimes different objects; also, because of the different cameras positions, an object recorded with the onboard camera might be visible at a different time compared to the GoPro. Since the bookmark is based on the onboard camera, viewers are advised to scroll in the GoPro video for about 20 seconds before/after the bookmark.

5.2.1 ROV survey

Turbulence was frequent near to the seafloor (greatest depth surveyed was 15.0 m) and increased closer to the WaveRoller foundation (e.g., WR_T1 11:15), making the ROV very difficult to operate.

During all transects the seafloor was mostly made of sandy substrate (e.g., WR_T1 11:02, WR_T2 12:32). Smaller areas with rocky substrate covered by sand (e.g., WR_T2 12:34, WR_T5 15:39) and few sections with rocky outcrops (e.g., WR_T1 11:10, WR_T2 12:35), “canyons” (WR_T2 12:36, WR_T4 14:53; Figure 38) and biogenic reefs (WR_T2 12:45 to 12:49) were identified.



Figure 38. Rocky “canyon” (GoPro video).

Along the transects several organisms were found, such as fishes (e.g., benthic: WR_T1 11:03, Figure 39; pelagic: WR_T2 12:43, WR_T5 15:30, Figure 40), sea urchins (e.g., WR_T4 14:37; Figure 41), starfishes (e.g., WR_T2 12:35 to 12:37; Figure 42), anemones (e.g., WR_T2 12:45; Figure 43 and Figure 44), red algae (e.g., WR_T2 12:34 and 12:42), and kelp (WR_T2 12:37), as well, as other organisms which were not possible to identify. Also, a massive biogenic *Sabellaria* reef was found in the vicinity of WaveRoller (WR_T2 12:45 to 12:49; Figure 44).



Figure 39. A skate fish on sandy bottom. (Onboard camera video).



Figure 40. Several fishes aggregating right next to the WaveRoller foundation. About 25 individuals could be counted. (GoPro camera)

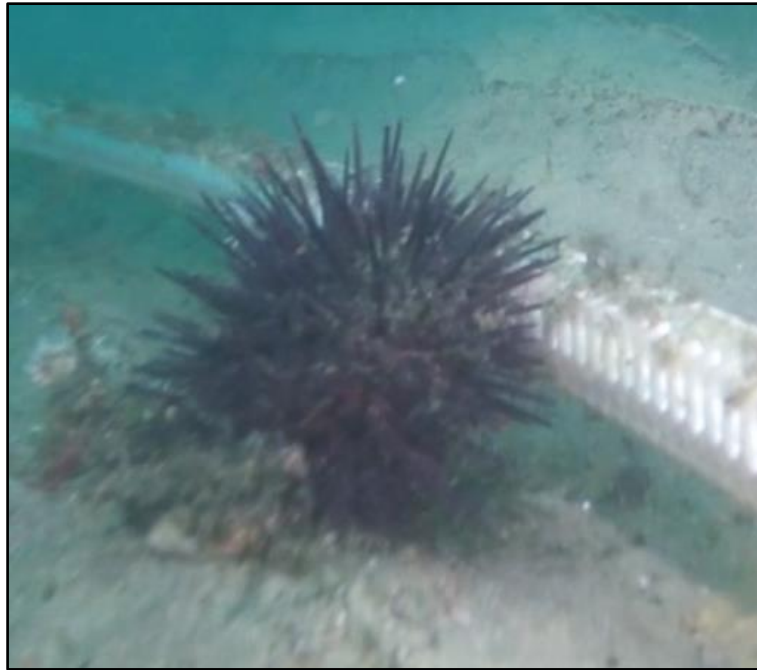

Figure 41. A sea urchin (*Paracentrotus lividus*) on a synthetic mooring cable. (GoPro camera).



Figure 42. Three starfishes on rocky bottom covered by sand. (GoPro camera).

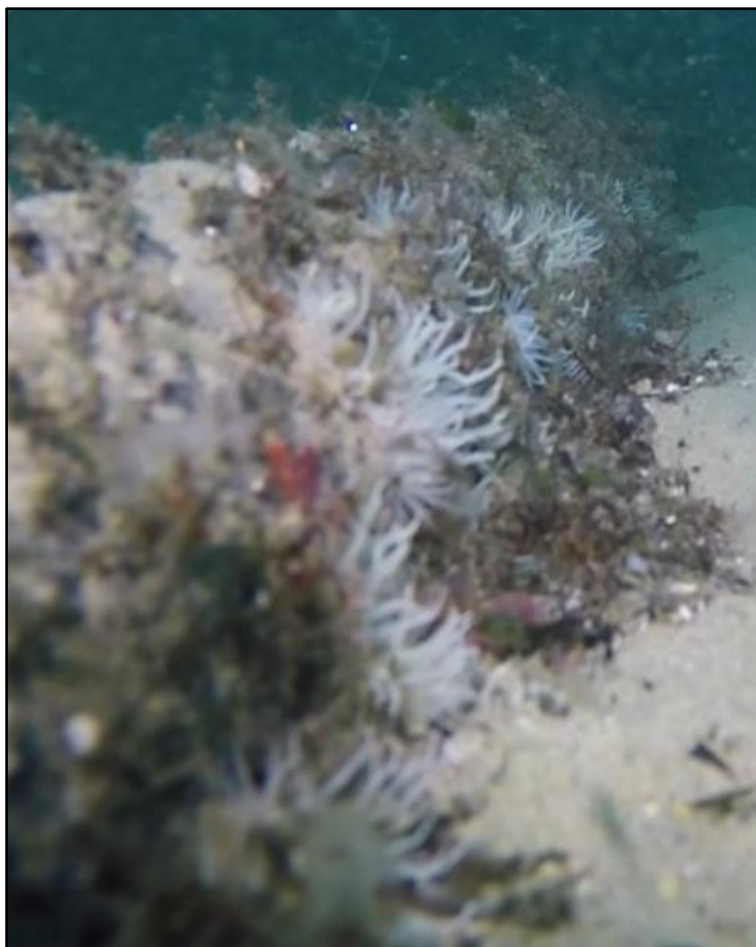

Figure 43. Electrical cable covered by sand and colonized by algae and anemones. (GoPro camera).



Figure 44. Portion of *Sabellaria* reef, with anemones and a starfish visible. (GoPro video).

Some artificial equipment/structures were found along the transects, namely two kinds of moorings, one made of steel and another synthetic (e.g., WR_T5 15:30 to 15:31;

Figure 45), and the WaveRoller electrical cable and foundation. Another object was found, a synthetic strap (Figure 46) probably used for lifting operations that remained on the seafloor.



Figure 45. A synthetic mooring cable crossing a steel mooring cable. (GoPro camera).



Figure 46. Synthetic strap colonized by algae. (GoPro camera)

All of the artificial items were colonized by organisms, also known as biofouling. The cables were especially colonized by algae and anemones (e.g., WR_T1 11:11 to 11:15; Figure 43) the foundation was greatly colonized by acorn barnacles, calcareous tubeworms and, in a much lesser extent, by mussels (e.g., WR_T4 14:56

to 14:58; Figure 47) and the synthetic strap was colonized by algae (WR_T3 13:41; Figure 46). Also, several fishes (about 25 individuals) were registered near to the WaveRoller foundation (WR_T4 14:41 to 14:43; Figure 40).

As far as the videos could capture, the WaveRoller unit seems not be impactful to the seafloor integrity. Three issues worthy to mention are:

- i) The mooring and electrical cables were completely lying on the seafloor, the only exception being a small portion of a steel mooring that was found on a rocky substrate/outcrop near to the foundation.

This could be owed to the great local hydrodynamics and to storms along the year, which according to the WaveRoller project manager *displace massive amounts of sand and are moved underwater from one area to another and that easily reveals the rocky substrate beneath the sandy one. It happens also in the beach shore.*





Figure 47. Colonization of the WaveRoller foundation: Top picture: lower section of the foundation colonized massively by barnacles (*Perforatus perforatus*) and calcareous tubeworms (cf. *Spirobranchus* sp.) (GoPro camera); Bottom picture: Mid section of the foundation colonized by barnacles and sparsely by mussels (*Mytilus galloprovincialis*) (Onboard camera video).

- ii) Also close to the foundation (~1 m from it), a small sand “dune” was found (WR_T4 14:56 to 14:57; Figure 48).

The “dune” could have been formed by sediments depositing behind the device as a consequence of its presence. The WaveRoller foundation was lifted for removal, which was later cancelled, hence, it was set back on the seafloor. Setting the foundation on the seafloor in a very close, but not the exact same area occupied previously might give the idea of a “dune”.

Nonetheless, owed to the great local hydrodynamics, that effect should be mitigated in few days. According to the WaveRoller project manager, *one week or one storm after you will find no evidence that a WaveRoller was installed in that area.*



Figure 48. Sand “dune” found near to the WaveRoller foundation (Onboard camera video)

- iii) A piece of a synthetic strap found on the seafloor, although possibly insignificant with regards to impacts, is evidence that wave energy projects as well as any anthropogenically driven activity at sea may represent some type of littering. In the case of objects that are easily seen (such as the strap), this is easily mitigated by looking out for drifting/sunk objects when performing diving inspections to the devices or their supporting structures.

On the other hand, positive effects could be expected regarding the presence of the WaveRoller and supporting structures with regards to seafloor communities. Artificial structures have the potential to act as artificial reefs providing a hard substrate for macroalgae settlement and for colonization by many marine invertebrates and, consequently, to attract/aggregate organisms from higher trophic levels, such as fish. Not only the artificial structures may represent increased local biomass and biodiversity, they may also boost the transportation of algal spores and invertebrate larvae to nearby areas, thus contributing to the enrichment of the communities there.

6. Future work

The results summarized in the present deliverable were collected in separated sampling surveys, as mentioned before, carried out using ROVs both in BiMEP and in Peniche, and using a side-scan SONAR in BiMEP. Although the side-scan SONAR survey failed in getting useful information, the ROV surveys produced video recordings the results included in the present deliverable are based on.

Links to the video recordings and metadata should be uploaded to MARENDATA in near future. Furthermore, they will be uploaded to an online video repository, using tags (bookmarking) referring to the items described in MARENDATA.

After the results obtained in this Deliverable, including the information related to the difficulties and limitations arisen during the surveys, consequently causing some deviations from the monitoring plans considered previously in Deliverable 2.1, recommendations will be included in Deliverable 2.6 on *Development of guidelines for environmental monitoring*.



Finally, it should be noted that the monitoring undertaken in the present project were carried out on single devices installed for testing purposes. Hence, how the results from them should be scaled to wave farms must be discussed and analysed.

7. Annexes

Annex 1. ROV dive logs (for the seafloor integrity monitoring at BIMEP).

Project name:	WESE	Project start date:	November 2018	Project end date:	November 2021	Project code:	WESE
---------------	------	---------------------	---------------	-------------------	---------------	---------------	------

ROV MONITORING RECORDING SHEET: 7 May 2019 Mutriku (Basque Country, Spain)

Location:	Armintza – BIMEP	Survey start date:	15 and 22 May 2019	Survey end date:	15 and 22 May 2019
Device:	MARMOK-A-5 of IDOM	Team:	Juan Bald (AZTI) Pedro Losa, Josu Merino, Imanol Bartolomé and Daniel Tavarez from Ekocean Josep Maria Rovirosa, Brais Lorenzo, Sergi Castellar and Josep Fleta from Instalsub		
Equipment:	ROV SEAEYE Falcon DR of Instalaciones Submarinas Bcn, S.A.	Boat:	Ekocean Explorer		
			Length: 11,95 m. Width: 5,64 m.		
15 May 2019					
Sea State	Wind Speed (knots): 6 Wind Speed (km/h): 5 Wind direction: 000° Sea-State (Beaufort force): 2 Wave height: 0.5 m				
Comments	The objective of the ROV inspection was to record images of the moorings, mooring lines and umbilical cable and connector of the MARMOK-A-5 device of IDOM. In the following picture we can see a detail of the mooring system of the IDOM device.				

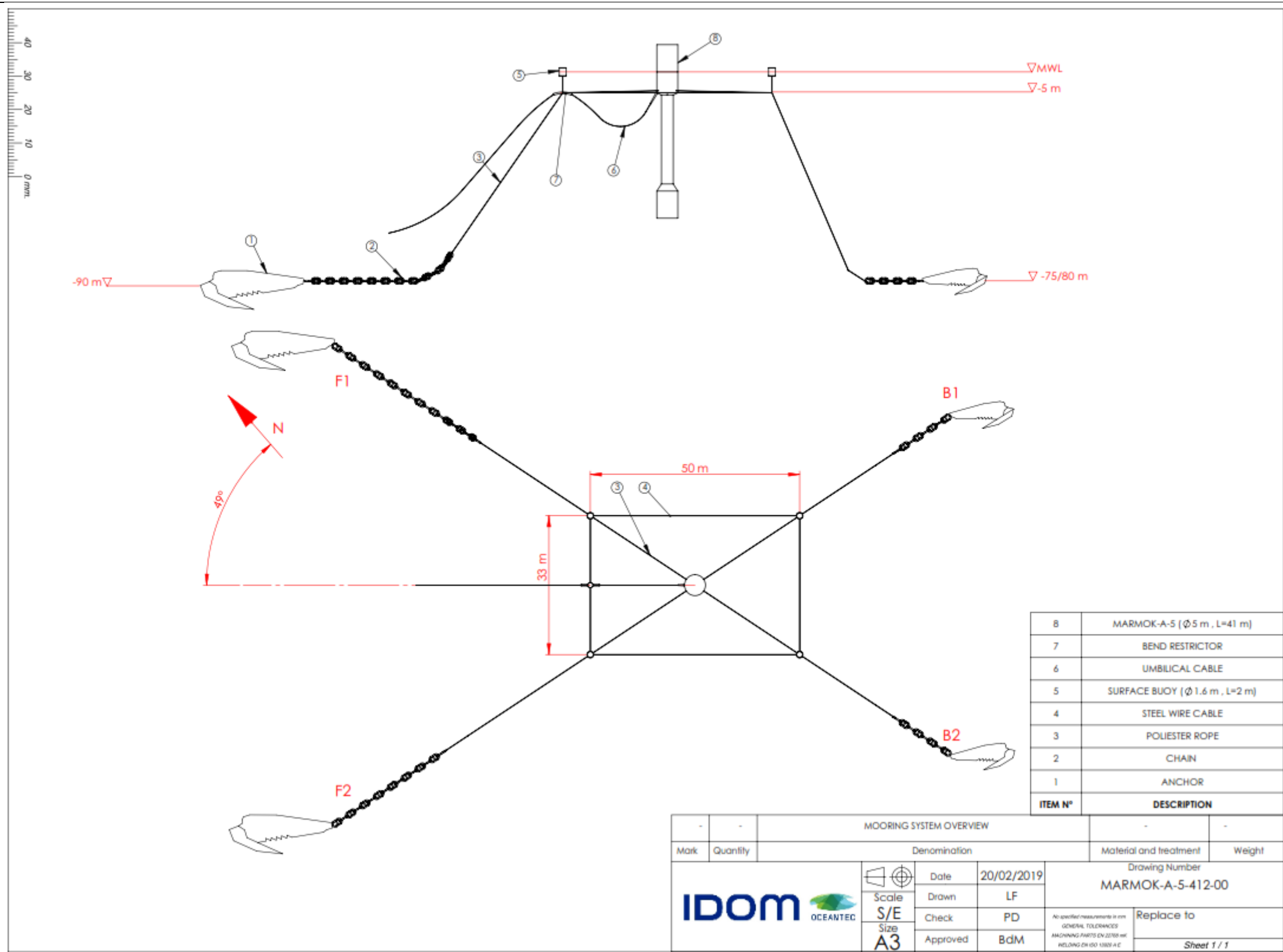

On the 15th May, we started with the searching of the F2 anchor. After 3 trials we give up. The ROV have experienced problems with the sonar. Thus, we decided to tie the vessel to the surface buoys and start recording all the mooring line until the landing of the line into the seafloor. Thus, we record the F2, F1 and umbilical cable landing but not all the mooring line travel in the seafloor until the anchor due to the long distance that should force us to spend lot of time navigating with the ROV and the sea state wasn't the best to do that.

	<p>In the case of B2 and B1 mooring lines, we recorded the B2 landing and all the travel of the mooring line until the anchor. In this case, these mooring lines are shorter than F1 and F2 and thus it has been possible to record all the mooring line. In the case of the B1, we tried to tie up the vessel to the surface buoy but the wind and waves introduced us inside the square of the mooring system making very risky any immersion of the ROV (riks of entanglement of the umbilical cable of the ROV with the mooring lines). Thus we gave up.</p> <p>On the 16th May we received a new sonar, but it wasn't possible to make the ROV work. Thus, we suspend the monitoring work until next week</p>
--	---

22 May 2019	
Sea State	Wind Speed (knots): Wind Speed (km/h): Wind direction: Sea-State (Beaufort force): Wave height:
Comments	<p>On the 22th May, we started with the searching of the B1 anchor and mooring line. The sonar was working ok, thus we managed to record the B1 anchor and all the mooring line until the landing. Then we managed to find the F1 anchor and the connector between the umbilical cable of the MARMOK-A-5 device and the export cable to land of the BiMEP infrastructure.</p> <p>During this works, the ROV have experienced problems with:</p> <ul style="list-style-type: none"> a) Geolocation of the ROV. Didn't work. b) The ROV switched off after 10 minutes after every immersion doing very difficult the inspection and giving us little time to do it.

Annex 2. Side-scan SONAR dive logs (for the seafloor integrity monitoring at BiMEP).

Project name:	WESE	Project start date:	November 2018	Project end date:	November 2021	Project code:	WESE
----------------------	------	----------------------------	---------------	--------------------------	---------------	----------------------	------

SIDE-SCAN SONAR MONITORING RECORDING SHEET: 7 May 2019 Mutriku (Basque Country, Spain)

Location:	Armintza – BiMEP	Survey start date:	14 May 2019	Survey end date:	14 May 2019
Device:	MARMOK-A-5 of IDOM	Team: Juan Bald (AZTI) Pedro Losa, Josu Merino, Imanol Bartolomé and Daniel Tavarez from Ekocean Jorge Rey and Roger Leis from ESGEMAR			
Equipment:	Side Scan Sonar of GEOACOUSTICS (100/500 kHz) of ESGEMAR S.A. Estudios Geológicos Marinos.	Boat: Ekocean Explorer			



Length: 11,95 m.
Width: 5,64 m.

			
<p>14 May 2019</p>			
<p>Sea State</p>	<p>Wind Speed (knots): Wind Speed (km/h): Wind direction: Sea-State (Beaufort force): Wave height: 1,5-2 m</p>		
<p>Comments</p>	<p>The objective of the ROV inspection was to record images of the moorings, mooring lines and umbilical cable and connector of the MARMOK-A-5 device of IDOM through different transects over these elements. These can be seen in the following picture:</p>		

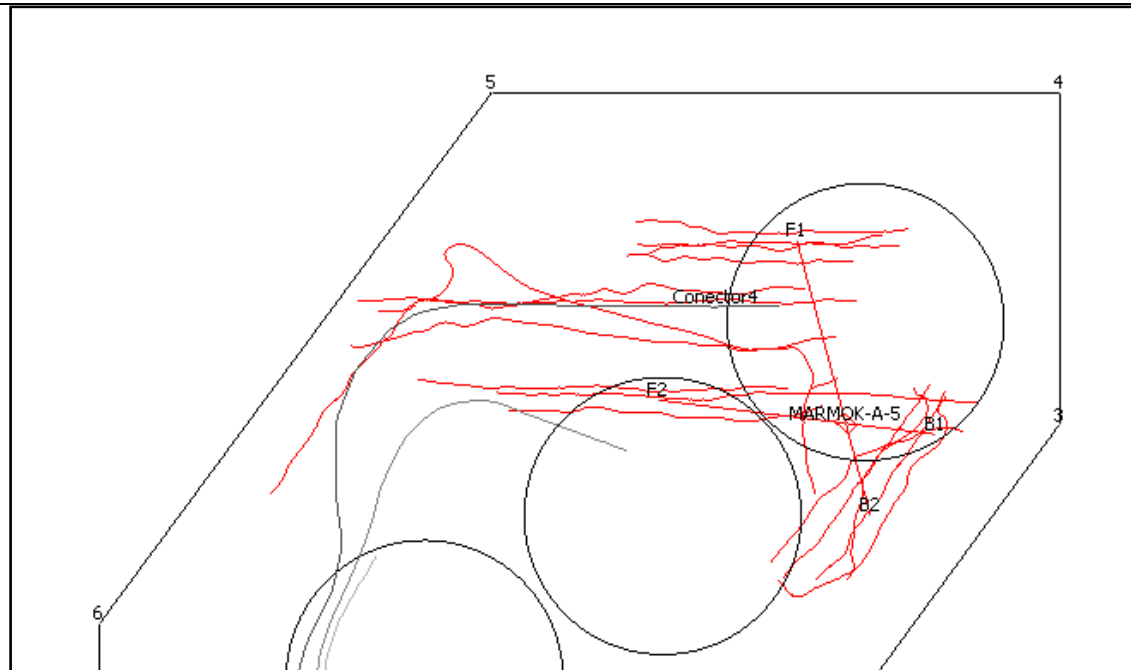

The work went well but the sea conditions were not the best for side scan sonar recording. For security reasons the transducer was not approached very close to the seafloor due to the risk of entanglement with the mooring lines. On the other hand, the waves provoked pulls in the system and consequently the introduction of artefacts in the data acquisition. Due to this, the obtained data are not the expected and didn't offer clear results.

Annex 3. ROV dive logs (for the seafloor integrity monitoring at the WaveRoller area.

Mission name	WESE – Monitoring of Seabed Integrity – Transect WR_T1		
ROV Operator(s)	Paulo Chainho		
Date	17/10/2020	Location	AW-E test site (Peniche)
Purpose of dive	Monitoring of Seabed Integrity		
Weather	Sunny to cloudy	Waves (WindGuru forecast for Peniche)	1.0-1.2 m NW-SE direction
Bottom type	Sandy with rocky outcrops		
Additional notes	Starting coordinates: 39°23.2959' N; 9°18.5263 W Intended heading: 43°		
No. of Dives	1	Video(s) ID(s)	Sáb_17_out_11_01.avi
GoPro video(s) ID(s)	GOPR4253; GP014253; GP024253		
Start time	Onboard camera: 11:01 GoPro: 10:53	End time	Onboard camera: 11:17 GoPro: 11:22
Total time:	16-29 min	Max tether used	104 m
Sensors/manipulators used	Lights; Laser system; Onboard camera; GoPro camera	Max Depth	12.8 m
Comments	<p>Turbulence was very high, considerably increased near the WaveRoller.</p> <p>Onboard camera register: 11:02:32 – Sandy bottom 11:03:10 – Skate 11:08:39 – Steel mooring cable 11:10:04 – Rocky outcrop, followed by rocky bottom covered by sand 11:11:28 – Electrical cable colonized by algae 11:13:02 to 11:13_45 – Other sections of the electrical cable colonized by algae 11:13:50, 11:14:26, 11:14:42 – Anemones and algae on the electrical cable; Almost reaching the foundation 11:15:15 – Reached WaveRoller foundation; Electrical cable greatly colonized by algae and anemones 11:15:31 – Foundation colonized by tubeworms and barnacles; Great turbulence</p>		

Mission name	WESE – Monitoring of Seabed Integrity – Transect WR_T2		
ROV Operator(s)	Paulo Chainho		
Date	17/10/2020	Location	AW-E test site (Peniche)
Purpose of dive	Monitoring of Seabed Integrity		
Weather	Sunny to cloudy	Waves (WindGuru forecast for Peniche)	1.2 m NW-SE direction
Bottom type	Sandy and rocky bottom, Rocky outcrops		
Additional notes	Starting coordinates: 39°23.3993' N; 9°18.4277' W Intended heading: 240°		
No. of Dives	1	Video(s) ID(s)	Sáb_17_out_12_32.avi
GoPro video(s) ID(s)	GOPR4262, GP014262, GP024262 (water column)		
Start time	Onboard camera: 12:32 GoPro: 12:30	End time	Onboard camera: 12:52 GoPro: 13:02
Total time:	20-32 min	Max tether used	100 m
Sensors/manipulators used	Lights; Laser system; Onboard camera; GoPro camera	Max Depth	13.5 m
Comments	<p>Turbulence was very high, considerably increased near to the WaveRoller.</p> <p>Onboard camera register: 12:32:25 – Sandy bottom 12:34:45 – Rocky bottom covered by sand, with red algae 12:35:11 – Rocky outcrop 12:35:33 – Starfishes and red algae 12:36:41 – Rocky “canyon” 12:36:52 – Starfishes and red algae 12:37:29 – Portion of kelp 12:37:42 – Starfishes, kelp 12:38:30 – Sandy Bottom 12:39:24 – Rocky outcrops with starfishes and algae 12:40 – ROV umbilical “stuck” in the vessel propeller 12:42 – Survey was resumed 12:43 – Sandy bottom 12:43:17 – Fish 12:43:08 – Fish 12:45:14 to 12:49 – Rocky outcrops with <i>Sabellaria</i> reefs 12:45:28 – Anemones among the <i>Sabellaria</i> 12:45:58 – Anemones and starfishes among the <i>Sabellaria</i></p>		

	12:46:27 – Rocky bottom covered by sand, with red algae 12:46:45 – Rocky outcrop 12:47:20 – Sandy Bottom; Turbulence increasing 12:49:49 to end – Great turbulence
--	---

Mission name	WESE – Monitoring of Seabed Integrity – Transect WR_T3		
ROV Operator(s)	Gonçalo Fonseca		
Date	17/10/2020	Location	AW-E test site (Almagreira, Peniche)
Purpose of dive	Monitoring of Seabed Integrity		
Weather	Sunny to cloudy	Waves (WindGuru forecast for Peniche)	1.0-1.2 m NW-SE direction
Bottom type	Sandy		
Additional notes	Starting coordinates: 39°23.3820' N; 9°18.5436' W Intended heading: 150°		
No. of Dives	1	Video(s) ID(s)	Sáb_17_out_13_34.avi
GoPro video(s) ID(s)	GOPR4266 (water column), GP014266, GP024266, GP034266 (water column)		
Start time	Onboard camera: 13:34 GoPro: 13:30	End time	Onboard camera: 13:54 GoPro: 14:09
Total time:	20 min	Max tether used	105 m
Sensors/manipulators used	Lights; Laser system; Onboard camera; GoPro camera	Max Depth	15.0 m
Comments	Turbulence was very high, considerably increased near the WaveRoller. We had to change position several times, because of the great turbulence and in the last position due to entanglement with cables not related to WaveRoller When we corrected the coordinates, we saw that the GoPro battery potentially needs to be replaced by a new one (discharges quickly). The team tried to correct the heading during the survey, which was not possible due to the great turbulence The ROV was taken out of water and it was prepared to deploy for the next transect. 13:41:24 – Synthetic strap with some algae 13:49:18 to – ROV movement unresponsive to commands; Checking thrusters; Reason: Entanglement with cable; Performing		

	<p>movements to free the ROV; Moved backwards to retrieve the ROV safely</p> <p>13:52:38 – Manometer (from gear used for decommissioning?)</p> <p>13:56:21 to 13:58:21 – Fish curious about the ROV</p>
--	---

Mission name	WESE – Monitoring of Seabed Integrity – Transect WR_T4		
ROV Operator(s)	Paulo Chainho		
Date	17/10/2020	Location	AW-E test site (Almagreira, Peniche)
Purpose of dive	Monitoring of Seabed Integrity		
Weather	Sunny to cloudy	Waves (WindGuru forecast for Peniche)	1.2 m
Bottom type	Sandy		
Additional notes	Starting coordinates: 39°23.3205' N; 9°18.5394' W Intended heading: 55°		
No. of Dives	1	Video(s) ID(s)	Sáb_17_out_14_32.avi
GoPro video(s) ID(s)	GOPR4269, GP014269		
Start time	14:33	End time	15:02
Total time:	29 min	Max tether used	80 m
Sensors/manipulators used	Lights; Laser system; Onboard camera; GoPro camera	Max Depth	14.8 m
Comments	<p>Turbulence was very high, considerably increased near the WaveRoller.</p> <p>We had to change position several times because of increasing severity of wind and waves.</p> <p>2 types of mooring cables were found, a steel cable and a synthetic cable.</p> <p>GoPro battery was discharged when the ROV was taken out of the water, meaning no recording with the GoPro for some of the last minutes of survey.</p> <p>14:37:29 to 14:38:10 and 14:39:14 – Synthetic mooring cable; Great turbulence</p>		

	<p>14:37:49 – Sea urchin; Synthetic mooring cable colonized by anemones</p> <p>14:39:06 – Rocky outcrop/rocky bottom</p> <p>14:39:13 – Synthetic mooring cable</p> <p>14:39:31 – Steel mooring cable</p> <p>14:40:52 – Electrical cable insert to the foundation</p> <p>14:41:14 to 14:42:02 – Electrical cable and foundation; Several fishes</p> <p>14:42:30 to 14:43:16 – Darker substrate (rocky bottom?); Fishes in the background</p> <p>14:44:00 – Biofouling detached from WaveRoller?</p> <p>14:45:55 to 14:47:00 – Sandy substrate; Great turbulence</p> <p>14:47:03 to 14:47:34 – Steel and synthetic mooring cables</p> <p>14:45 – GoPro battery discharged</p> <p>14:49:34 – Steel and synthetic mooring cables</p> <p>14:53:05 – Electrical cable on rocky bottom; Rocky “canyon” on the left</p> <p>14:53:35 to 14:56:23 – WaveRoller foundation, highly colonized by barnacles and tubeworms</p> <p>14:54:05 to 14:54:34 – Rocky outcrop covered by sand?</p> <p>14:54:44 and 14:54:51 – Undistinguishable organisms: Sea urchins?</p> <p>14:56:37 to 14:57:42 – Small sand “dune” near the foundation</p> <p>14:56:40 to 14:58:09 – WaveRoller foundation colonized by barnacles, tubeworms, and mussels</p>
--	---

Mission name	WESE – Monitoring of Seabed Integrity – Transect WR_T5		
ROV Operator(s)	Paulo Chainho		
Date	17/10/2020	Location	AW-E test site (Almagreira, Peniche)
Purpose of dive	Monitoring of Seabed Integrity		
Weather	Sunny to cloudy	Waves	1.2 m (WindGuru forecast for Peniche)
Bottom type	Sandy		
Additional notes	Starting coordinates: 39°23.3190' N; 9°18.4734' W Intended heading: 335°		
No. of Dives	1	Video(s) ID(s)	Sáb_17_out_15_30.avi
GoPro videos ID(s)	GOPR4270, GP014270		
Start time	Onboard camera: 15:30 GoPro: 15:28	End time	Onboard camera: 15:44 GoPro:
Total time:	14-20 min	Max tether used	80 m

Sensors/manipulators used	Lights; Laser system; Onboard camera; GoPro camera	Max Depth	15.0 m
Comments	<p>Turbulence was very high, considerably increased near the WaveRoller. We had to change position several times because of increasing severity of wind and waves. It was impossible to record the seabed near the front section of the foundation (facing the shore) because of extreme turbulence. 2 types of mooring cables were found, a steel cable and a synthetic cable</p> <p>15:30:24 to 15:31:06 – Steel mooring cable 15:30:27 – Couple of fishes 15:31:06 – Synthetic mooring cable 15:31:15 to 15:32:41 – Continued following the steel mooring cable; Turbulence increasing 15:32:41 – Synthetic mooring cable colonized by algae 15:33:11 to 15:33:20 – Rocky bottom covered by sand; Steel mooring cable through the rocky bottom 15:33:22 to 15:37:05 – WaveRoller foundation colonized by tubeworms and barnacles; Great turbulence 15:39:10 – Steel mooring cable 15:39:40 – Rocky bottom covered by sand 15:40:25 – Steel mooring cable</p>		



This project has been funded by the European Commission under the European Maritime and Fisheries Fund (EMFF), Call for Proposals EASME/EMFF/2017/1.2.1.1 – “Environmental monitoring of wave and tidal devices”. This communication reflects only the author’s view. EASME is not responsible for any use that may be made of the information it contains.

