

Exponent[®]

*Electrical Engineering and Computer
Science Practice*

**Deepwater Wind South Fork
Wind Farm**

**Onshore Electric and
Magnetic Field Assessment**



Deepwater Wind South Fork Wind Farm

Onshore Electric and Magnetic Field Assessment

Prepared for

Deepwater Wind, LLC
56 Exchange Terrace, Suite 300
Providence, RI 02903

Prepared by

Exponent Engineering, P.C.
420 Lexington Avenue
Suite 1740
New York, NY 10170

May 31, 2018

© Exponent, Inc.

Contents

	<u>Page</u>
List of Figures	iii
List of Tables	iv
Acronyms and Abbreviations	v
Limitations	vi
Executive Summary	viii
Introduction	1
Project Description	1
Electric and Magnetic Fields	3
Relevant Standards	3
Modeling Methodology and Assumptions	5
Description of Onshore Cable Configurations	5
Magnetic Field	6
Electric Field	7
Model Results	8
Conclusions	12
Appendix A	Cable Configurations and Duct Bank Cross Sections
Appendix B	Input Data for Transmission Line Magnetic-Field Calculations
Appendix C	Output Results for Transmission Line Magnetic-Field Calculations

List of Figures

	<u>Page</u>
Figure 1. Overview of the proposed route options of the SFEC-Onshore cable.	2
Figure 2. Magnetic-field levels for the onshore 138-kV transmission line where it is installed parallel to roads.	9
Figure 3. Magnetic-field levels for the onshore 138-kV transmission line where it is installed parallel to a railway.	10
Figure 4. Magnetic-field levels for the onshore 69-kV transmission line where it is installed parallel to a railway.	11

List of Tables

	<u>Page</u>
Table 1. Summary of onshore modeling configurations	6
Table 2. Modeled magnetic-field level (mG) calculated at 1 meter above ground for WNC rating and for the maximum output of the SFWF	9

Acronyms and Abbreviations

A	Amperes
DWSF	Deepwater Wind South Fork, LLC
EMF	Electric and magnetic fields
Exponent	Exponent Engineering, P.C.
G	Gauss
HDD	Horizontal directional drilling
Hz	Hertz
ICES	International Committee on Electromagnetic Safety
ICNIRP	International Commission on Non-Ionizing Radiation
IEEE	Institute of Electrical and Electronics Engineers
kV	Kilovolt
LIPA	Long Island Power Authority
mG	Milligauss
mV/m	millivolts per meter
MW	Megawatt
NYPSC	New York Public Service Commission
ROW	Right of way
SFWF	South Fork Wind Farm
SFEC	South Fork Export Cable
SFEC-OCS	South Fork Export Cable on the Outer Continental Shelf
SFEC-Onshore	South Fork Export Cable on land
SNC-Lavalin Inc.	SNC-Lavalin
WNC	Winter normal conductor

Limitations

At the request of SNC-Lavalin Inc. (SNC-Lavalin) and Deepwater Wind South Fork, LLC (DWSF), Exponent modeled anticipated magnetic-field levels from the submarine and underground transmission lines proposed for this Project.

This report summarizes the analysis performed to date and presents the findings resulting from that work. In the analysis, we have relied on transmission line design geometry, usage, specifications, and various other types of information provided by SNC-Lavalin. We cannot verify the correctness of this input data and rely on the SNC-Lavalin for the data's accuracy. Although Exponent has exercised usual and customary care in the conduct of this analysis, the responsibility for the design and operation of the Project remains fully with the client. SNC-Lavalin has confirmed to Exponent that the data contained herein are not subject to Critical Energy Infrastructure Information restrictions.

The findings presented herein are made to a reasonable degree of engineering and scientific certainty. Exponent reserves the right to supplement this report and to expand or modify opinions based on review of additional material as it becomes available, through any additional work, or review of additional work performed by others.

The scope of services performed during this investigation may not adequately address the needs of other users of this report, and any re-use of this report or its findings, conclusions, or recommendations presented herein for purposes other than permitting of this project are at the sole risk of the user. The opinions and comments formulated during this assessment are based on observations and information available at the time of the investigation. No guarantee or warranty as to future life or performance of any reviewed condition is expressed or implied.

Benjamin R.T. Cotts, Ph.D., P.E. (Licensed Electrical Engineer, California, #21277) and Kevin L. Graf, Ph.D., P.E. (Licensed Electrical Engineer, California, #21433), both employed by Exponent Inc., performed calculations of the magnetic and electric fields associated with the operation of the proposed Project. Joshua Phinney, Ph.D., P.E. (New York P.E., License No. 084129), also employed by Exponent, has reviewed this work.

Reviewed By:



Joshua Phinney, P.E.



Executive Summary

At the request of SNC-Lavalin Inc. (SNC-Lavalin) and Deepwater Wind South Fork, LLC (DWSF), Exponent modeled the magnetic fields anticipated to be produced during operation of underground transmission lines that convey electricity generated by the South Fork Wind Farm (SFWF) to the existing Long Island Power Authority's East Hampton Substation. The modeling included calculations of magnetic fields from 138-kilovolt (kV) and 69-kV lines for three onshore configurations running in underground duct banks to the existing East Hampton Substation.

The proposed transmission lines were modeled for line loadings equal to the winter normal conductor (WNC) ratings as well as the maximum assumed 132-megawatt output of the SFWF turbines. The electric field from the underground and submarine transmission cables is blocked by the cable armoring as well as the earth and therefore will not be a direct source of any electric field outside the cables.

Modeling results under WNC conditions show that the maximum magnetic field ± 50 feet from the duct bank centerline in all portions of the route are below 200 milligauss for the proposed configurations of the transmission lines and thus comply with the magnetic-field guidelines of the New York State Public Service Commission.

Note that this Executive Summary does not contain all of Exponent's technical evaluations, analyses, conclusions, and recommendations. Hence, the main body of this report is at all times the controlling document.

Introduction

Project Description

Deepwater Wind (DWW) proposes to construct the offshore South Fork Wind Farm (SFWF). It is assumed in this analysis that the maximum output of the SFWF will be 132 megawatts (MW). This electricity will be generated by up to 15 offshore wind turbines and will be carried at a voltage of 34.5-kilovolt (kV) over inter-array cables to an offshore substation where the voltage will be converted to 138 kV. At this voltage, the electricity will be carried to land via the South Fork Export Cable (SFEC), where it will transition to an underground duct bank then to an onshore substation. At the onshore substation, voltage will be converted down to 69 kV to be carried to the existing Long Island Power Authority (LIPA) East Hampton Substation.

This report presents analysis of the onshore portion of the proposed route including the 138-kV and 69-kV underground cables (SFEC-Onshore cables) connecting the Project to the existing LIPA East Hampton Substation as well as the portion of the SFEC installed by horizontal directional drilling (HDD) beneath at the sea-shore landing. The assessment of the electric and magnetic fields from the inter-array cable and the SFEC on the Outer Continental Shelf (SFEC-OCS) is provided in the companion report titled Deepwater Wind South Fork Wind Farm—Offshore Electric and Magnetic Field Assessment.

At the request of SNC-Lavalin Inc. (SNC-Lavalin) and DWSF, Exponent modeled the 60-Hertz (Hz) magnetic field for three configurations of the onshore transmission cables. An overview of the proposed options for the onshore route between the Atlantic Ocean and the LIPA East Hampton Substation is shown in Figure 1. Each of the three route options includes a 138-kV underground transmission line to be installed in an underground duct bank and a separate 138-kV duct bank configuration where the 138-kV line parallels railways. In addition, over a short portion of the route between the onshore DWSF Substation and the LIPA East Hampton Substation, the transmission line operates at 69 kV and parallels a railway.

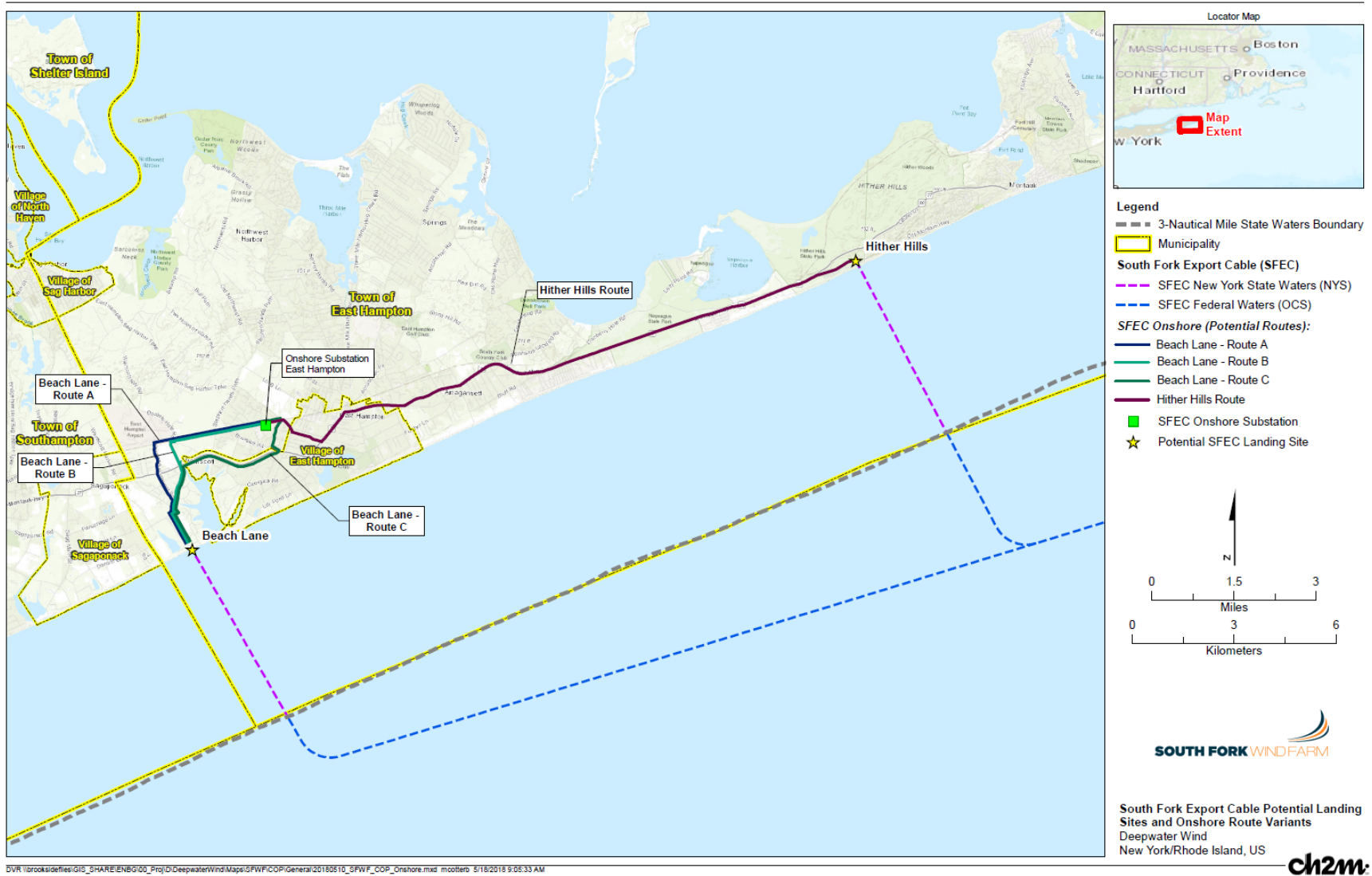

Figure 1. Overview of the proposed route options of the SFEC-Onshore cable.

Electric and Magnetic Fields

Like all wiring and equipment connected to the electrical system, the electric and magnetic fields (EMF) surrounding cables associated with the SFWF will oscillate with a frequency of 60 Hz. The magnetic field results from the flow of electricity along the cable and the magnetic flux density is reported in units of milligauss (mG), where 1 Gauss (G) = 1,000 mG. The magnetic field will be strongest at the surface of the cable and will decrease rapidly with distance from the cables. The voltage applied to the conductors within the cable creates an electric field, but the conductive sheathing of the cables and the ground itself will block electric fields from the cables and will eliminate the electric fields above ground.

Since load currents—expressed in units of amperes (A)—generate magnetic fields around the conductors, measurements or calculations of these fields present a snapshot for the load conditions at only one moment in time. On a given day, throughout a week, or over the course of months or years, the field levels can change depending upon the power generated by the turbines, which depends on wind speed and operational status. One way to address the potential variability of this load is to perform calculations for the maximum output of the SFWF (assumed at 132 MW), which provides the maximum magnetic field expected for the proposed Project. The state of New York also requires that calculations of magnetic fields from transmission lines be performed for line loadings at the winter normal conductor (WNC) rating of the transmission line cable, which provides the maximum magnetic field that can be sustained continuously by the conductors during winter months when temperatures are lower and hence it is generally possible to operate transmission lines at a higher current.¹ Each of these two loading scenarios, 132 MW output and WNC rating, will be used to calculate magnetic fields in this report.

Relevant Standards

New transmission lines constructed in the state of New York operating at voltages above

¹ In contrast a short-term emergency or long term-emergency rating of the cable may allow larger levels of current to pass through the cable, but this can occur only for a limited duration before the cable becomes damaged.

100 kV must comply with the interim EMF limits on emissions from the lines published by the New York Public Service Commission (NYPSC). The magnetic field limit at ± 50 feet from the center of the transmission lines with voltages less than 230 kV is 200 mG when modeled at WNC rating of the conductors.^{2,3,4}

In addition, two international organizations provide guidance on human exposure to magnetic fields. This guidance is the result of extensive review and evaluations of relevant research of health and safety issues, and the limits they propose are designed to protect health and safety of persons in an occupational setting and for the general public. The International Committee on Electromagnetic Safety (ICES), which operates “under the rules and oversight of the IEEE Standards Association Board,”⁵ developed a maximum permissible exposure limit to magnetic fields of 9,040 mG for the general public. The International Commission on Non-Ionizing Radiation (ICNIRP), an independent scientific organization providing scientific advice and guidance on the health and environmental effects of non-ionizing radiation, recommended a reference level limit for whole-body exposure to 60-Hz magnetic fields of 2,000 mG.⁶

² The New York Public Service Commission also requires a not to exceed electric-field limit at the ROW edge of new transmission lines of 1.6 kilovolts per meter. Since the electric field from the underground transmission cables is blocked by the cable shielding as well as the earth, the Project will not be a direct source of any electric field.

³ New York Public Service Commission (NYPSC). Statement of Interim Policy on Magnetic Fields of Major Transmission Facilities. Cases 26529 and 26559 Proceeding on Motion of the Commission. Issued and Effective: September 11, 1990; New York Public Service Commission (NYPSC). Opinion No. 78-13 Case 26529 and 26559, Issued June 19, 1978.

⁴ As stated in the NYPSC’s 1990 Interim Policy, “When transmission lines are constructed within or across public thoroughfares, the term “right-of-way” is not directly applicable. For the purpose of this interim standard, typical right-of-way widths will be used in those circumstances: ...100 feet for lower voltage circuits [< 230 kV], with the transmission line centered.” In cases where the transmission lines are constructed outside specified rights of way, field calculations are presented at a distance of ± 50 feet from the duct bank centerline.

⁵ <http://www.ices-emfsafety.org/>

⁶ International Committee on Electromagnetic Safety (ICES). IEEE Standard for Safety Levels with Respect to Human Exposure to Electromagnetic Fields 0 to 3 kHz. Piscataway, NJ: IEEE, 2002 (reaffirmed 2005); International Commission on Non-ionizing Radiation Protection (ICNIRP). Guidelines for limiting exposure to time-varying electric and magnetic fields (1 Hz to 100 kHz). Health Phys 99: 818-836, 2010.

Modeling Methodology and Assumptions

To evaluate the magnetic and electric fields in the vicinity of the Project, Exponent calculated the 60-Hz fields from the proposed transmission line at maximum theoretical loadings (using parameters specified in the permitting design and conservative modeling assumptions that overestimate the field levels that measured after construction). Based on these data, the magnetic fields at a height of 1 meter above ground were calculated and compared to NYPSC guidelines.

Description of Onshore Cable Configurations

The proposed transmission line between the Project and the LIPA East Hampton Substation will consist of three onshore configurations as indicated in Table 1. The 138-kV line is modeled where it is parallel to roads, as well as where it is parallel to the railway. The duct banks for both 138-kV configurations are identical (see Appendix A, Figure A-1) and differ only in terms of burial depth, the right-of-way (ROW) width and placement of the duct bank in the ROW. The minimum ROW width and minimum distance to the edge of the ROW are summarized in Table 1. The 69-kV duct bank will be constructed in a different configuration, as shown in Appendix A, Figure A-2 and cross sections of the single-core cables are shown in Appendix A, Figure A-3.

At the sea-to-shore landing transition of the offshore 138-kV SFEC, the SFEC will be installed via HDD.⁷ As shown in Appendix A, Figure A-5, burial depth over this portion of the route is expected to be significantly greater than in other portions of the route, with most of the HDD at least 30 feet beneath the seabed and beach and a maximum of about 60 feet beneath the dunes. Over the last 100-200 feet before entering the transition vault, the burial depth decreases to a

⁷ At an underground transition vault, the conductors of the offshore three-core cable will be spliced to the three single-core onshore cables. A cross section of the SFEC-Offshore cable is shown in Appendix A, Figure A-4.

minimum of approximately 7 feet. The magnetic-field level from the cable above ground will be much lower over the HDD portion of the cable due to the greater burial depth.⁸

Table 1. Summary of onshore modeling configurations

Configuration	3*	4	5
Description	Export Cable Parallel to road	Export Cable Parallel to railway	69-kV line Parallel to railway
Voltage (kV)	138		69
Loading at 132 MW Output (Amps)	800		1267
Loading at WNC Rating (Amps)	1000 [†]		1541
Cable Type	1-core, 3.44" OD		1-core, 3.43" OD
Conductor	1750 MCM		3000 MCM
Installation Type	4x2 vertical duct bank		1x4 horizontal duct bank
Burial Depth (to top of duct bank)	20-25 inches		
Height of evaluation	1 meter above ground		
Minimum ROW Width (feet)	46.5	54.3	58.3
Minimum distance to ROW edge (feet)	7.6	-3.9	13.1

* Configurations 1a, 1b, 2a, and 2b are located offshore and are analyzed separately in a companion report, Deepwater Wind South Fork Wind Farm Offshore Electric and Magnetic Field Assessment Deepwater Wind South Fork Wind Farm—Offshore Electric and Magnetic Field Assessment.

† Consistent with the NYPSC Statement of Interim Policy on Magnetic Fields of Major Electric Transmission Facilities under Article VII (NYPSC, 1990), these results are provided for WNC rating of the cable. The limiting factor in current transfer is the SFEC-Offshore. The WNC rating for the SFEC-Offshore is 755 Amps as discussed in the companion report titled Deepwater Wind South Fork Wind Farm—Offshore Electric and Magnetic Field Assessment.

Magnetic Field

SNC-Lavalin provided data to Exponent regarding the preliminary cable and duct bank design as well as loadings for each proposed transmission line configuration. This input data is included in Appendix B. From these data, Exponent developed models of the three onshore duct banks for computation of the magnetic fields. The magnetic fields were calculated from the current flow, phasing, and conductor configurations. Consistent with the NYPSC Statement

⁸ Greater detail about the calculated magnetic field above the SFEC-OCS is provided in a companion report, titled Deepwater Wind South Fork Wind Farm—Offshore Electric and Magnetic Field Assessment.

of Interim Policy on Magnetic Fields of Major Electric Transmission Facilities under Article VII (New York interim magnetic field standard),⁹ magnetic-field levels are calculated at a height of 1 meter above ground and are reported in units of mG as the maximum root-mean-square flux density value.

Magnetic-field levels were calculated using computer algorithms developed by the Bonneville Power Administration, an agency of the U.S. Department of Energy.¹⁰ These algorithms have been shown to accurately predict magnetic fields near overhead and underground transmission lines, and are expected to overestimate the magnetic-field levels from the underground cables.

All magnetic-field calculations are made assuming that the conductors of the transmission line are parallel to one another and infinite in extent. Additionally, the models assume that the load on the phase conductors is balanced, that there is no attenuation of magnetic fields from any surrounding material and there are no unbalanced currents flowing along the outer sheaths of the cables. These modeling assumptions were made to ensure that the calculated magnetic-field levels will overestimate the actual field level at any specified loading.¹¹

Electric Field

Electric fields due to the voltage applied to the conductors within the transmission line cables were not calculated because these fields are totally shielded by grounded metallic sheaths and the ground itself around each cable. For comparison to relevant standards, calculated magnetic fields at a height of 1 meter above ground are presented in the section below.

⁹ New York Public Service Commission (NYPSC). Statement of Interim Policy on Magnetic Fields of Major Transmission Facilities. Cases 26529 and 26559 Proceeding on Motion of the Commission. Issued and Effective: September 11, 1990 and NYPSC Opinion No. 78-13 Case 26529 and 26559, Issued June 19, 1978.

¹⁰ Bonneville Power Administration (BPA). Corona and Field Effects Computer Program. Portland, OR: Bonneville Power Administration, 1991.

¹¹ The design and construction of the offshore cables (and HDD) include cable armoring, sheathing and helical twisting of the conductors within the cable. As described in detail in the companion report “Deepwater Wind South Fork Wind Farm—Offshore Electric and Magnetic Field Assessment”, these design features will reduce the magnetic-field level outside the cable below those reported here for the HDD configuration.

Model Results

Exponent calculated the 60-Hz magnetic fields from the proposed 138-kV and 69-kV lines at maximum theoretical loadings using the methods described above. Numerical results of these calculations are summarized below for magnetic-field levels above ground. Appendix B contains all input data used for these calculations and Appendix C contains all the calculated magnetic-field values at 1-foot intervals at a height of 1 meter above ground.

The results of the magnetic-field modeling are shown below in Figure 2 through Figure 4 and a summary of magnetic-field levels in the three onshore route sections at WNC rating and at the maximum output of the SFWF is shown in Table 2. Electric fields from the voltage on the proposed underground transmission conductors will be shielded by the conductive sheaths and ground around the transmission line conductors and so above ground electric-field levels were not calculated.

As shown in Table 2, the magnetic-field level ± 50 feet from the duct bank centerline at a height of 1 meter above ground is a maximum of 4.7 mG in the portion paralleling the railroad, far below the NYPSC's 200-mG limit.

Magnetic-field levels at the beach HDD section are far lower than elsewhere along the route due to the very deep burial of the cable. The maximum calculated magnetic-field level at WNC loading (directly above the HDD cable) is 0.3 mG at a burial depth of 62 feet, 1.8 mG at a burial depth of 22 feet, and 11 mG at a burial depth of 7 feet.

Table 2. Modeled magnetic-field level (mG) calculated at 1 meter above ground for WNC rating and for the maximum output of the SFWF

Section	Loading	-50 feet	Max	+50 feet
138-kV Parallel Roads	132 MW WNC	1.7 2.1	118 147	1.7 2.1
138-kV Parallel Railway	132 MW WNC	1.7 2.1	103 129	1.7 2.1
69-kV Parallel Railway	132 MW WNC	3.8 4.7	253 308	3.7 4.5

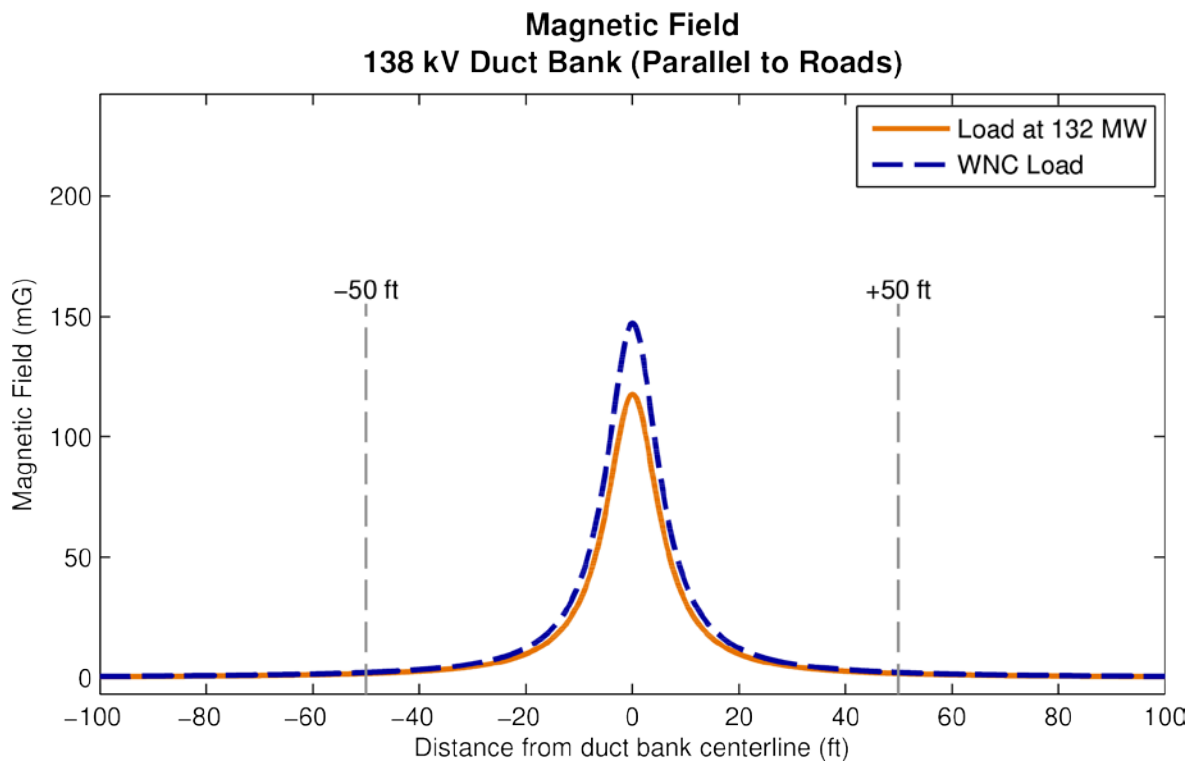

Figure 2. Magnetic-field levels for the onshore 138-kV transmission line where it is installed parallel to roads.

Magnetic-field levels are calculated at 1 meter above ground for both WNC rating and at assumed maximum output (132 MW) of the SFWF.

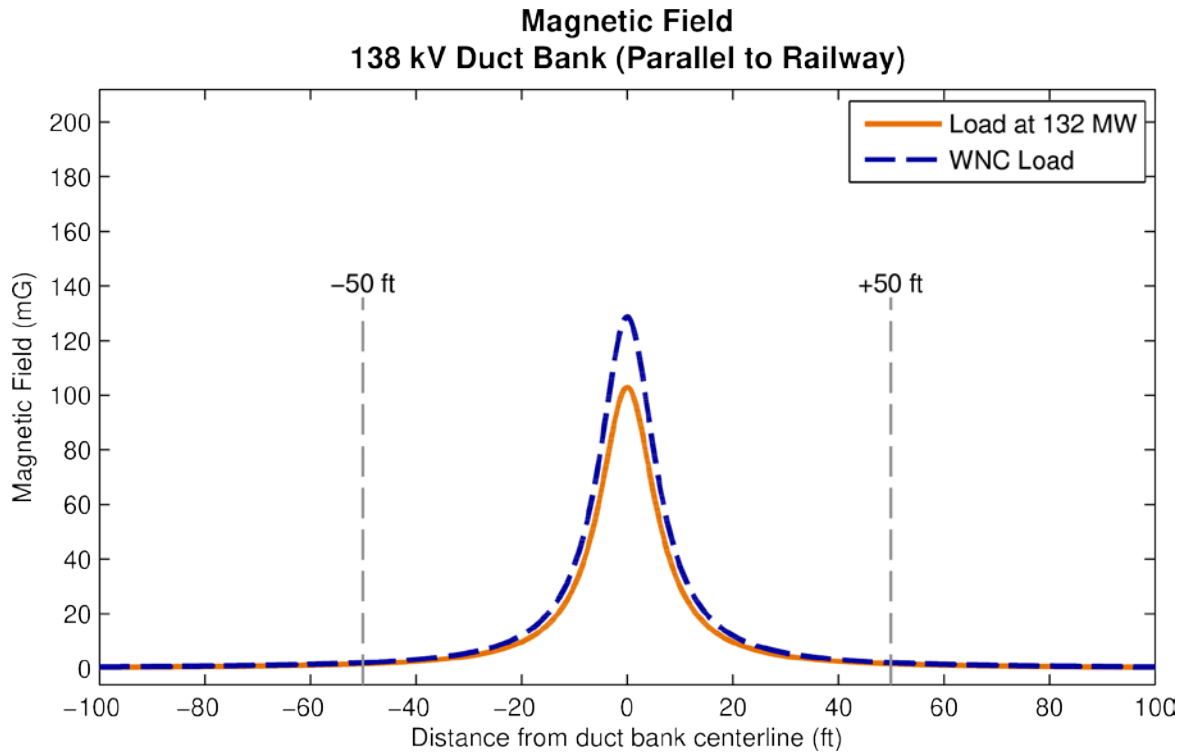

Figure 3. Magnetic-field levels for the onshore 138-kV transmission line where it is installed parallel to a railway.

Magnetic-field levels are calculated at 1 meter above ground for both WNC rating and at assumed maximum output (132 MW) of the SFWF.

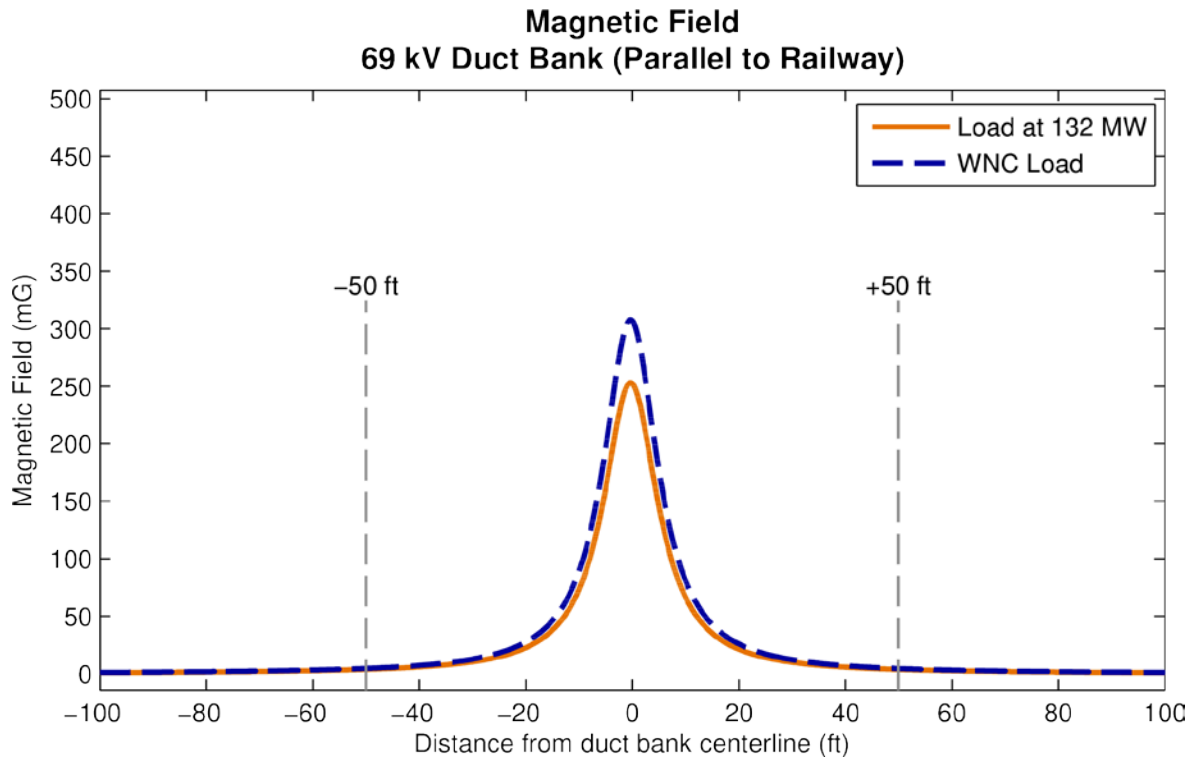

Figure 4. Magnetic-field levels for the onshore 69-kV transmission line where it is installed parallel to a railway.

Magnetic field levels are calculated at 1 meter above ground for both WNC rating and at assumed maximum output (132 MW) of the SFWF.

Conclusions

Exponent conducted modeling of the magnetic-field levels associated with the underground 138-kV and 69-kV transmission cables proposed as part of the Project. This report summarizes the analysis of the onshore portion of the Project.

Modeling of the magnetic field at WNC ratings shows that the magnetic field ± 50 feet from the duct bank centerline at 1 meter above ground is below 200 mG everywhere along the Project. Thus, calculations of the magnetic field in accordance with the NYPSC's magnetic-field standard demonstrate compliance of the Project with this standard.¹²

The calculated magnetic-field levels also are well below the ICNIRP reference level of 2,000 mG and the ICES maximum permissible exposure limit of 9,040 mG for the general population.

The electric field from the underground transmission cables is blocked by the cable armoring as well as the earth and so will not be a direct source of any electric field outside the cables.

¹² The NYPSC also requires a not-to-exceed electric-field limit at the ROW edge of new transmission lines of 1.6 kilovolts per meter. Since the electric field from the submarine and underground transmission cables is blocked by the cable shielding as well as the earth, the Project will not be a direct source of any electric field.

Appendix A

Cable Configurations and Duct Bank Cross Sections

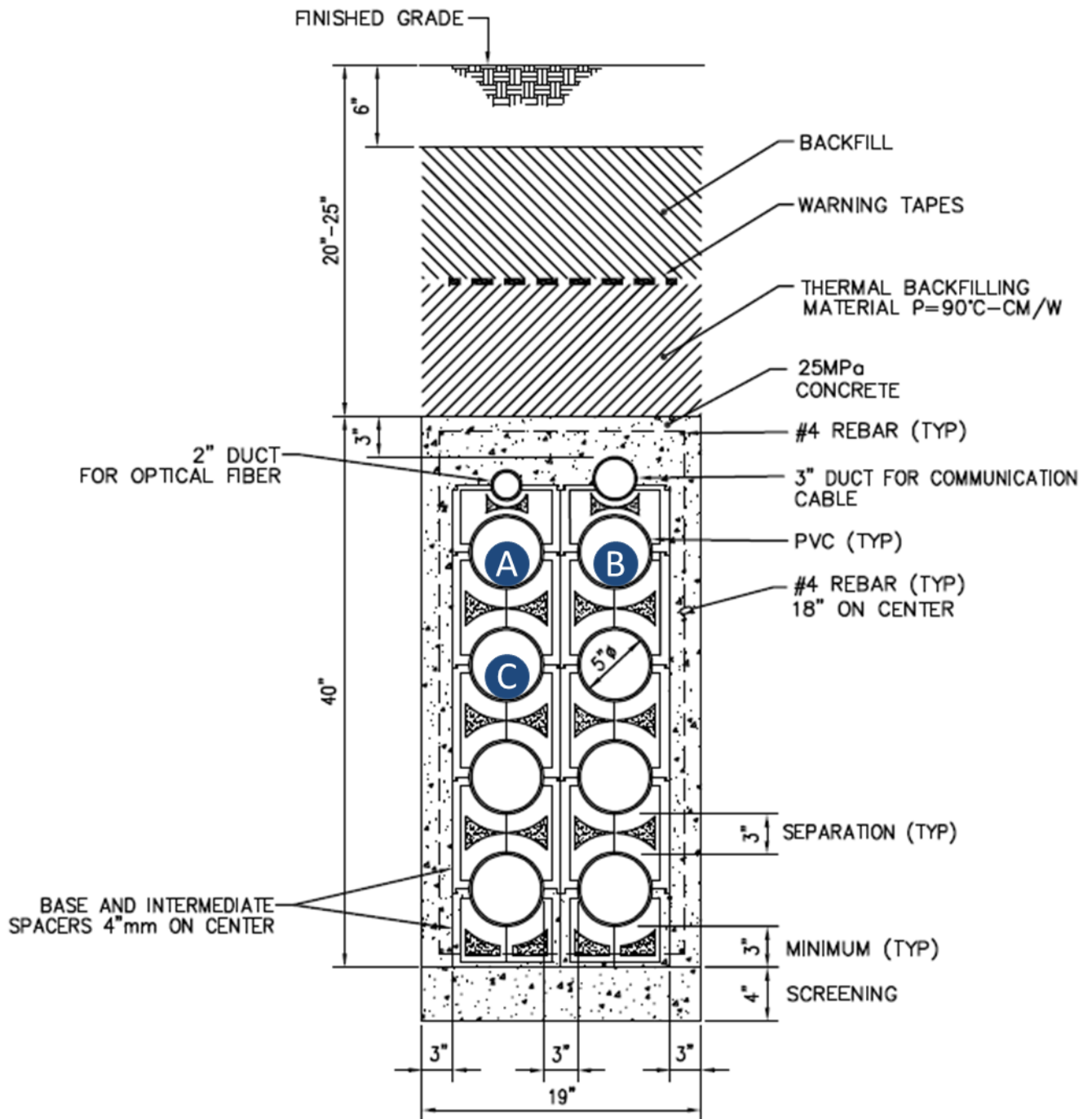

Figure A-1. Onshore 138-kV duct bank where it is proposed to be constructed both parallel to roads and parallel to the railway.

Where the duct bank is proposed to be installed parallel to roads the anticipated burial depth is 20 inches, where it is proposed to be installed parallel to the railway the burial depth is 25 inches.

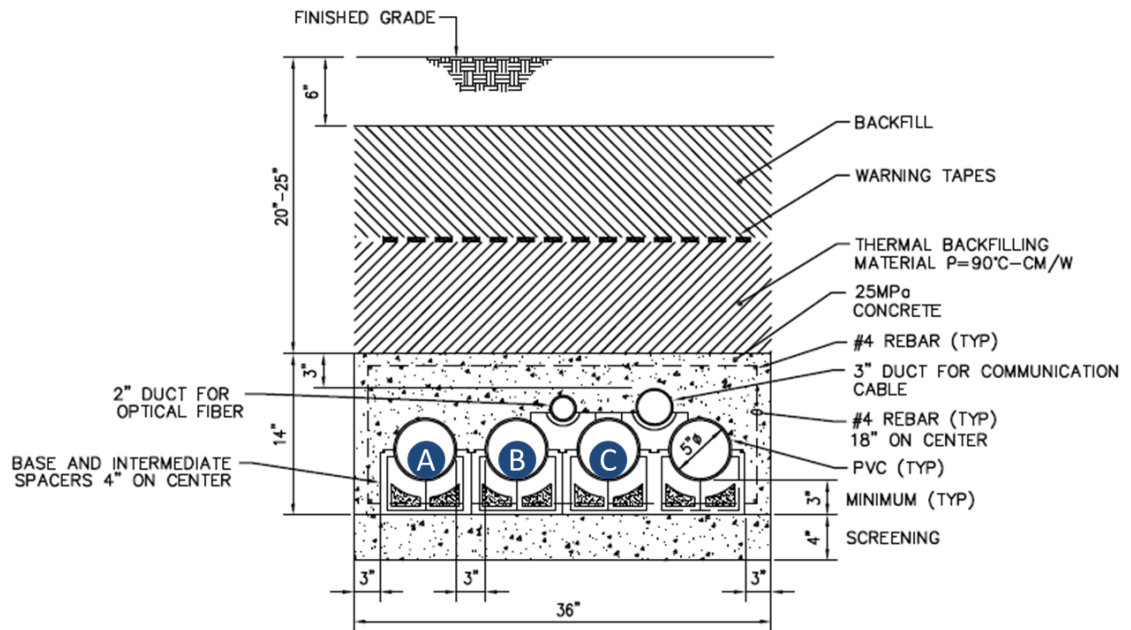

Figure A-2. Onshore 69-kV duct bank where it is proposed to be constructed parallel to the railway.

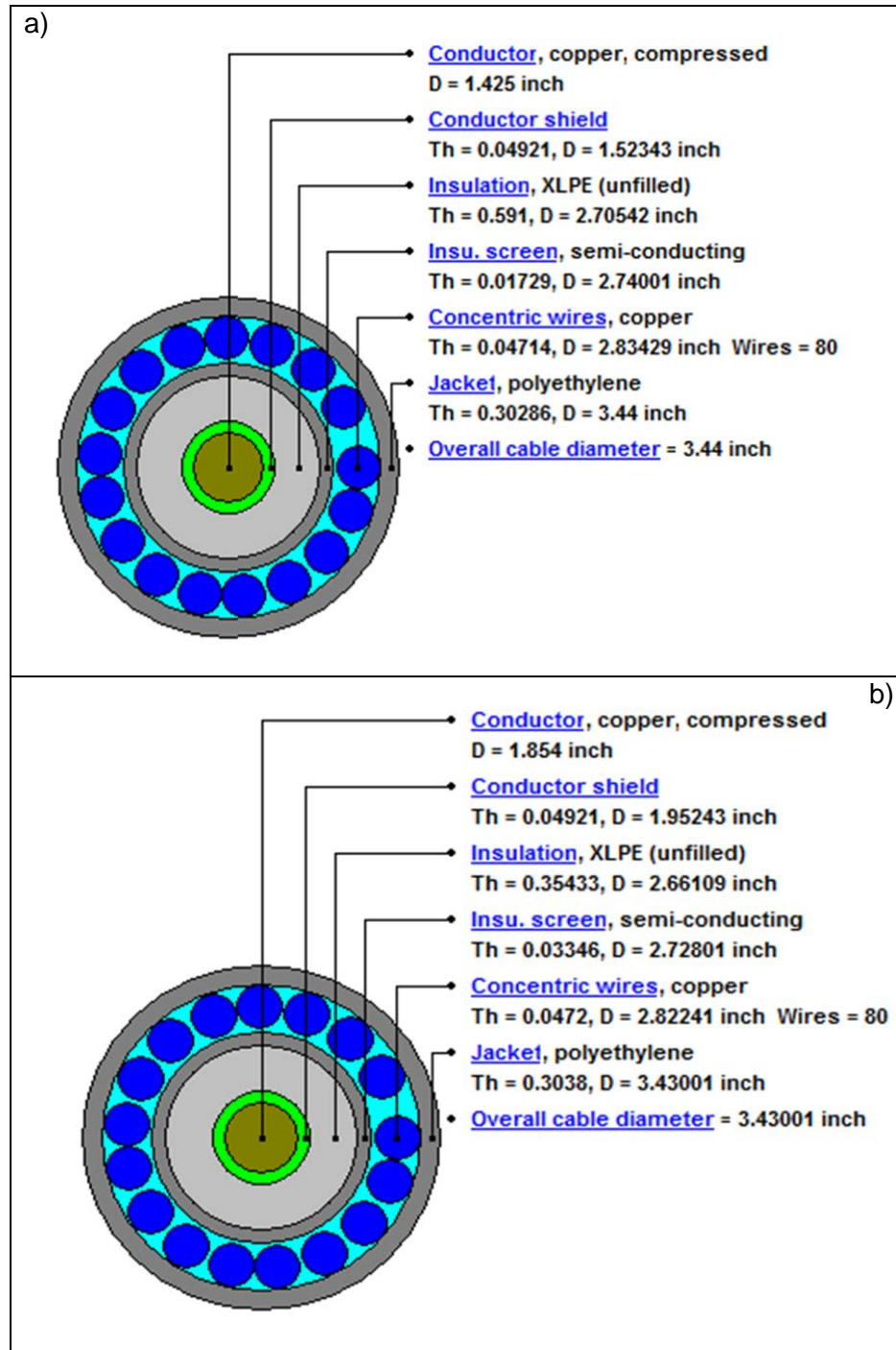

Figure A-3. Cross section of the onshore single-core cables for a) the 138-kV duct banks and b) the 69-kV duct banks.

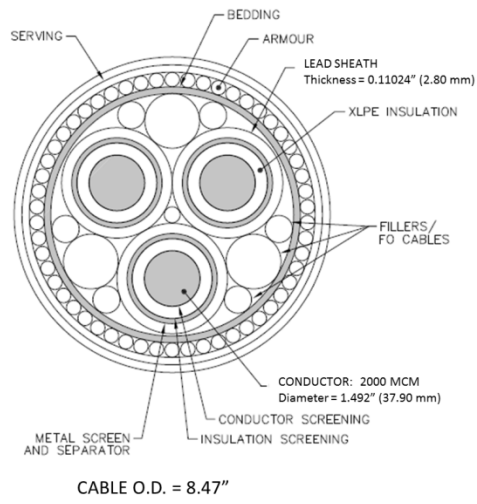

Figure A-4. Cross section of the SFEC-Offshore three-core cable where it is installed via HDD.

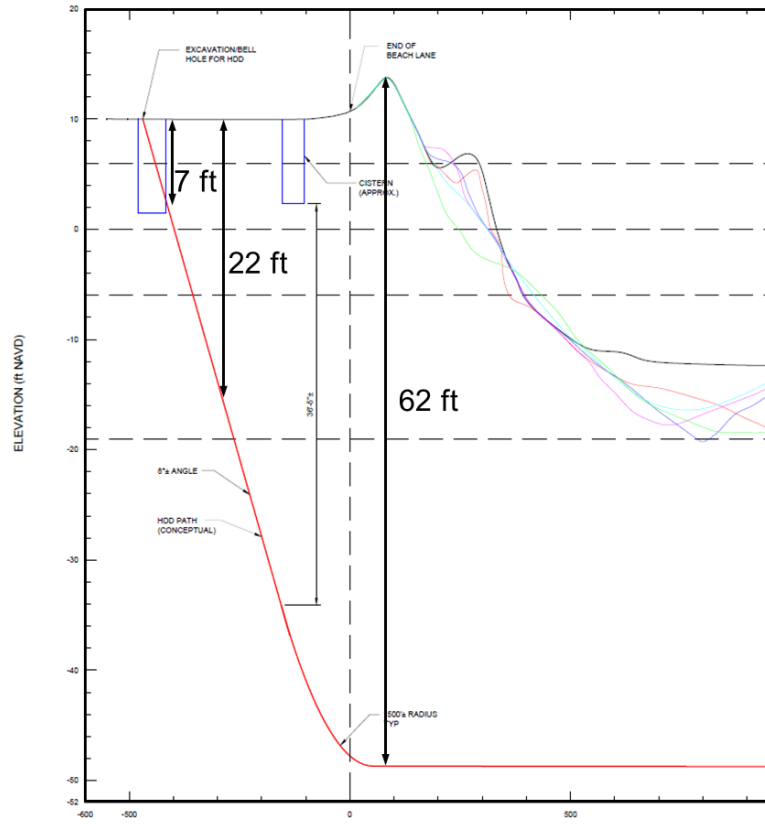

Figure A-5. Depiction of the approximate burial depth of the SFEC where it is installed via HDD at the shore landing/beach.

Appendix B

Input Data for Transmission Line Magnetic Field Calculations

Table B-1. XS-3: 138 kV SFEC-Onshore Duct Bank (Parallel to Roads) at 132 MW

Bundle	x-feet	y-feet	number cond	cond dia (inches)	Bundle Separation (in)	I-n voltage (kV)	V Phase	Current (A)¹³	Line Voltage (nominal)	Current Phase
1	7.13	-2.42	1	1.425	0	79.67	0	800	138	0
2	7.79	-2.42	1	1.425	0	79.67	240	800	138	240
3	7.13	-3.08	1	1.425	0	79.67	120	800	138	120

Table B-2. XS-3: 138 kV SFEC-Onshore Duct Bank (Parallel to Roads) at WNC rating¹³

Bundle	x-feet	y-feet	number cond	cond dia (inches)	Bundle Separation (in)	I-n voltage (kV)	V Phase	Current (A)	Line Voltage (nominal)	Current Phase
1	7.13	-2.42	1	1.425	0	79.67	0	1000	138	0
2	7.79	-2.42	1	1.425	0	79.67	240	1000	138	240
3	7.13	-3.08	1	1.425	0	79.67	120	1000	138	120

Table B-3. XS-4: 138 kV SFEC-Onshore Duct Bank (Parallel to Railway) at 132 MW¹³

Bundle	x-feet	y-feet	number cond	cond dia (inches)	Bundle Separation (in)	I-n voltage (kV)	V Phase	Current (A)	Line Voltage (nominal)	Current Phase
1	16.60	-2.83	1	1.425	0	79.67	0	800	138	0
2	17.26	-2.83	1	1.425	0	79.67	240	800	138	240
3	16.60	-3.5	1	1.425	0	79.67	120	800	138	120

¹³ The limiting factor in current transfer is the SFEC-Offshore. The WNC rating for the SFEC-Offshore is 755 Amperes as discussed in the companion report titled Deepwater Wind South Fork Wind Farm—Offshore Electric and Magnetic Field Assessment.

Table B-4. XS-4: 138 kV SFEC-Onshore Duct Bank (Parallel to Railway) at WNC rating¹³

Bundle	x-feet	y-feet	number cond	cond dia (inches)	Bundle Separation (in)	I-n voltage (kV)	V Phase	Current (A)	Line Voltage (nominal)	Current Phase
1	16.60	-2.83	1	1.425	0	79.67	0	1000	138	0
2	17.26	-2.83	1	1.425	0	79.67	240	1000	138	240
3	16.60	-3.5	1	1.425	0	79.67	120	1000	138	120

Table B-5. XS-5: 69 kV SFEC-Onshore Duct Bank (Parallel to Railway) at 132 MW

Bundle	x-feet	y-feet	number cond	cond dia (inches)	Bundle Separation (in)	I-n voltage (kV)	V Phase	Current (A)	Line Voltage (nominal)	Current Phase
1	14.77	-2.83	1	1.854	0	39.84	0	1267	69	0
2	15.44	-2.83	1	1.854	0	39.84	240	1267	69	240
3	16.1	-2.83	1	1.854	0	39.84	120	1267	69	120

Table B-6. XS-5: 69 kV SFEC-Onshore Duct Bank (Parallel to Railway) at WNC rating

Bundle	x-feet	y-feet	number cond	cond dia (inches)	Bundle Separation (in)	I-n voltage (kV)	V Phase	Current (A)	Line Voltage (nominal)	Current Phase
1	14.77	-2.83	1	1.854	0	39.84	0	1541	69	0
2	15.44	-2.83	1	1.854	0	39.84	240	1541	69	240
3	16.1	-2.83	1	1.854	0	39.84	120	1541	69	120

Appendix C

Output Results for Transmission Line Magnetic Field Calculations

Table C-1. Calculated Output Results for Magnetic Field Onshore Calculations (Major Axis, mG)

Dist (ft) from duct bank centerline	138-kV Onshore (Parallel Roads)		138-kV Onshore (Parallel Railway)		69-kV Onshore (Parallel Railway)	
	132 MW Load	WNC Rating	132 MW Load	WNC Rating	132 MW Load	WNC Rating
-500	0.42	0.53	0.42	0.53	0.96	1.17
-499	0.42	0.53	0.42	0.53	0.96	1.17
-498	0.42	0.53	0.42	0.53	0.96	1.17
-497	0.42	0.53	0.42	0.53	0.96	1.17
-496	0.42	0.53	0.42	0.53	0.96	1.17
-495	0.42	0.53	0.42	0.53	0.96	1.17
-494	0.42	0.53	0.42	0.53	0.96	1.17
-493	0.42	0.53	0.42	0.53	0.96	1.17
-492	0.42	0.53	0.42	0.53	0.96	1.17
-491	0.42	0.53	0.42	0.53	0.96	1.17
-490	0.42	0.53	0.42	0.53	0.96	1.17
-489	0.42	0.53	0.42	0.53	0.96	1.17
-488	0.42	0.53	0.42	0.53	0.96	1.17
-487	0.42	0.53	0.42	0.53	0.96	1.17
-486	0.42	0.53	0.42	0.53	0.96	1.17
-485	0.42	0.53	0.42	0.53	0.96	1.17
-484	0.42	0.53	0.42	0.53	0.96	1.17
-483	0.42	0.53	0.42	0.53	0.96	1.17
-482	0.42	0.53	0.42	0.53	0.96	1.17
-481	0.42	0.53	0.42	0.53	0.96	1.17
-480	0.42	0.53	0.42	0.53	0.96	1.17
-479	0.42	0.53	0.42	0.53	0.96	1.17
-478	0.42	0.53	0.42	0.53	0.96	1.17
-477	0.42	0.53	0.42	0.53	0.96	1.17
-476	0.42	0.53	0.42	0.53	0.96	1.17
-475	0.42	0.53	0.42	0.53	0.96	1.17
-474	0.42	0.53	0.42	0.53	0.96	1.17
-473	0.42	0.53	0.42	0.53	0.96	1.17
-472	0.42	0.53	0.42	0.53	0.96	1.17
-471	0.42	0.53	0.42	0.53	0.96	1.17
-470	0.42	0.53	0.42	0.53	0.96	1.17
-469	0.42	0.53	0.42	0.53	0.96	1.17
-468	0.42	0.53	0.42	0.53	0.96	1.17
-467	0.42	0.53	0.42	0.53	0.96	1.17
-466	0.42	0.53	0.42	0.53	0.96	1.17
-465	0.42	0.53	0.42	0.53	0.96	1.17
-464	0.42	0.53	0.42	0.53	0.96	1.17

Dist (ft) from duct bank centerline	138-kV Onshore (Parallel Roads)		138-kV Onshore (Parallel Railway)		69-kV Onshore (Parallel Railway)	
	132 MW Load	WNC Rating	132 MW Load	WNC Rating	132 MW Load	WNC Rating
-463	0.42	0.53	0.42	0.53	0.96	1.17
-462	0.42	0.53	0.42	0.53	0.96	1.17
-461	0.42	0.53	0.42	0.53	0.96	1.17
-460	0.42	0.53	0.42	0.53	0.96	1.17
-459	0.42	0.53	0.42	0.53	0.96	1.17
-458	0.42	0.53	0.42	0.53	0.96	1.17
-457	0.42	0.53	0.42	0.53	0.96	1.17
-456	0.42	0.53	0.42	0.53	0.96	1.17
-455	0.42	0.53	0.42	0.53	0.96	1.17
-454	0.42	0.53	0.42	0.53	0.96	1.17
-453	0.42	0.53	0.42	0.53	0.96	1.17
-452	0.42	0.53	0.42	0.53	0.96	1.17
-451	0.42	0.53	0.42	0.53	0.96	1.17
-450	0.42	0.53	0.42	0.53	0.96	1.17
-449	0.42	0.53	0.42	0.53	0.96	1.17
-448	0.42	0.53	0.42	0.53	0.96	1.17
-447	0.42	0.53	0.42	0.53	0.96	1.17
-446	0.42	0.53	0.42	0.53	0.96	1.17
-445	0.42	0.53	0.42	0.53	0.96	1.17
-444	0.42	0.53	0.42	0.53	0.96	1.17
-443	0.42	0.53	0.42	0.53	0.96	1.17
-442	0.42	0.53	0.42	0.53	0.96	1.17
-441	0.42	0.53	0.42	0.53	0.96	1.17
-440	0.42	0.53	0.42	0.53	0.96	1.17
-439	0.42	0.53	0.42	0.53	0.96	1.17
-438	0.42	0.53	0.42	0.53	0.96	1.17
-437	0.42	0.53	0.42	0.53	0.96	1.17
-436	0.42	0.53	0.42	0.53	0.96	1.17
-435	0.42	0.53	0.42	0.53	0.96	1.17
-434	0.42	0.53	0.42	0.53	0.96	1.17
-433	0.42	0.53	0.42	0.53	0.96	1.17
-432	0.42	0.53	0.42	0.53	0.96	1.17
-431	0.42	0.53	0.42	0.53	0.96	1.17
-430	0.42	0.53	0.42	0.53	0.96	1.17
-429	0.42	0.53	0.42	0.53	0.96	1.17
-428	0.42	0.53	0.42	0.53	0.96	1.17
-427	0.42	0.53	0.42	0.53	0.96	1.17
-426	0.42	0.53	0.42	0.53	0.96	1.17

Dist (ft) from duct bank centerline	138-kV Onshore (Parallel Roads)		138-kV Onshore (Parallel Railway)		69-kV Onshore (Parallel Railway)	
	132 MW Load	WNC Rating	132 MW Load	WNC Rating	132 MW Load	WNC Rating
-425	0.42	0.53	0.42	0.53	0.96	1.17
-424	0.42	0.53	0.42	0.53	0.96	1.17
-423	0.42	0.53	0.42	0.53	0.96	1.17
-422	0.42	0.53	0.42	0.53	0.96	1.17
-421	0.42	0.53	0.42	0.53	0.96	1.17
-420	0.42	0.53	0.42	0.53	0.96	1.17
-419	0.42	0.53	0.42	0.53	0.96	1.17
-418	0.42	0.53	0.42	0.53	0.96	1.17
-417	0.42	0.53	0.42	0.53	0.96	1.17
-416	0.42	0.53	0.42	0.53	0.96	1.17
-415	0.42	0.53	0.42	0.53	0.96	1.17
-414	0.42	0.53	0.42	0.53	0.96	1.17
-413	0.42	0.53	0.42	0.53	0.96	1.17
-412	0.42	0.53	0.42	0.53	0.96	1.17
-411	0.42	0.53	0.42	0.53	0.96	1.17
-410	0.42	0.53	0.42	0.53	0.96	1.17
-409	0.42	0.53	0.42	0.53	0.96	1.17
-408	0.42	0.53	0.42	0.53	0.96	1.17
-407	0.42	0.53	0.42	0.53	0.96	1.17
-406	0.42	0.53	0.42	0.53	0.96	1.17
-405	0.42	0.53	0.42	0.53	0.96	1.17
-404	0.42	0.53	0.42	0.53	0.96	1.17
-403	0.42	0.53	0.42	0.53	0.96	1.17
-402	0.42	0.53	0.42	0.53	0.96	1.17
-401	0.42	0.53	0.42	0.53	0.96	1.17
-400	0.42	0.53	0.42	0.53	0.96	1.17
-399	0.42	0.53	0.42	0.53	0.96	1.17
-398	0.42	0.53	0.42	0.53	0.96	1.17
-397	0.42	0.53	0.42	0.53	0.96	1.17
-396	0.42	0.53	0.42	0.53	0.96	1.17
-395	0.42	0.53	0.42	0.53	0.96	1.17
-394	0.42	0.53	0.42	0.53	0.96	1.17
-393	0.42	0.53	0.42	0.53	0.96	1.17
-392	0.42	0.53	0.42	0.53	0.96	1.17
-391	0.42	0.53	0.42	0.53	0.96	1.17
-390	0.42	0.53	0.42	0.53	0.96	1.17
-389	0.42	0.53	0.42	0.53	0.96	1.17
-388	0.42	0.53	0.42	0.53	0.96	1.17

Dist (ft) from duct bank centerline	138-kV Onshore (Parallel Roads)		138-kV Onshore (Parallel Railway)		69-kV Onshore (Parallel Railway)	
	132 MW Load	WNC Rating	132 MW Load	WNC Rating	132 MW Load	WNC Rating
-387	0.42	0.53	0.42	0.53	0.96	1.17
-386	0.42	0.53	0.42	0.53	0.96	1.17
-385	0.42	0.53	0.42	0.53	0.96	1.17
-384	0.42	0.53	0.42	0.53	0.96	1.17
-383	0.42	0.53	0.42	0.53	0.96	1.17
-382	0.42	0.53	0.42	0.53	0.96	1.17
-381	0.42	0.53	0.42	0.53	0.96	1.17
-380	0.42	0.53	0.42	0.53	0.96	1.17
-379	0.42	0.53	0.42	0.53	0.96	1.17
-378	0.42	0.53	0.42	0.53	0.96	1.17
-377	0.42	0.53	0.42	0.53	0.96	1.17
-376	0.42	0.53	0.42	0.53	0.96	1.17
-375	0.42	0.53	0.42	0.53	0.96	1.17
-374	0.42	0.53	0.42	0.53	0.96	1.17
-373	0.42	0.53	0.42	0.53	0.96	1.17
-372	0.42	0.53	0.42	0.53	0.96	1.17
-371	0.42	0.53	0.42	0.53	0.96	1.17
-370	0.42	0.53	0.42	0.53	0.96	1.17
-369	0.42	0.53	0.42	0.53	0.96	1.17
-368	0.42	0.53	0.42	0.53	0.96	1.17
-367	0.42	0.53	0.42	0.53	0.96	1.17
-366	0.42	0.53	0.42	0.53	0.96	1.17
-365	0.42	0.53	0.42	0.53	0.96	1.17
-364	0.42	0.53	0.42	0.53	0.96	1.17
-363	0.42	0.53	0.42	0.53	0.96	1.17
-362	0.42	0.53	0.42	0.53	0.96	1.17
-361	0.42	0.53	0.42	0.53	0.96	1.17
-360	0.42	0.53	0.42	0.53	0.96	1.17
-359	0.42	0.53	0.42	0.53	0.96	1.17
-358	0.42	0.53	0.42	0.53	0.96	1.17
-357	0.42	0.53	0.42	0.53	0.96	1.17
-356	0.42	0.53	0.42	0.53	0.96	1.17
-355	0.42	0.53	0.42	0.53	0.96	1.17
-354	0.42	0.53	0.42	0.53	0.96	1.17
-353	0.42	0.53	0.42	0.53	0.96	1.17
-352	0.42	0.53	0.42	0.53	0.96	1.17
-351	0.42	0.53	0.42	0.53	0.96	1.17
-350	0.42	0.53	0.42	0.53	0.96	1.17

Dist (ft) from duct bank centerline	138-kV Onshore (Parallel Roads)		138-kV Onshore (Parallel Railway)		69-kV Onshore (Parallel Railway)	
	132 MW Load	WNC Rating	132 MW Load	WNC Rating	132 MW Load	WNC Rating
-349	0.42	0.53	0.42	0.53	0.96	1.17
-348	0.42	0.53	0.42	0.53	0.96	1.17
-347	0.42	0.53	0.42	0.53	0.96	1.17
-346	0.42	0.53	0.42	0.53	0.96	1.17
-345	0.42	0.53	0.42	0.53	0.96	1.17
-344	0.42	0.53	0.42	0.53	0.96	1.17
-343	0.42	0.53	0.42	0.53	0.96	1.17
-342	0.42	0.53	0.42	0.53	0.96	1.17
-341	0.42	0.53	0.42	0.53	0.96	1.17
-340	0.42	0.53	0.42	0.53	0.96	1.17
-339	0.42	0.53	0.42	0.53	0.96	1.17
-338	0.42	0.53	0.42	0.53	0.96	1.17
-337	0.42	0.53	0.42	0.53	0.96	1.17
-336	0.42	0.53	0.42	0.53	0.96	1.17
-335	0.42	0.53	0.42	0.53	0.96	1.17
-334	0.42	0.53	0.42	0.53	0.96	1.17
-333	0.42	0.53	0.42	0.53	0.96	1.17
-332	0.42	0.53	0.42	0.53	0.96	1.17
-331	0.42	0.53	0.42	0.53	0.96	1.17
-330	0.42	0.53	0.42	0.53	0.96	1.17
-329	0.42	0.53	0.42	0.53	0.96	1.17
-328	0.42	0.53	0.42	0.53	0.96	1.17
-327	0.42	0.53	0.42	0.53	0.96	1.17
-326	0.42	0.53	0.42	0.53	0.96	1.17
-325	0.42	0.53	0.42	0.53	0.96	1.17
-324	0.42	0.53	0.42	0.53	0.96	1.17
-323	0.42	0.53	0.42	0.53	0.96	1.17
-322	0.42	0.53	0.42	0.53	0.96	1.17
-321	0.42	0.53	0.42	0.53	0.96	1.17
-320	0.42	0.53	0.42	0.53	0.96	1.17
-319	0.42	0.53	0.42	0.53	0.96	1.17
-318	0.42	0.53	0.42	0.53	0.96	1.17
-317	0.42	0.53	0.42	0.53	0.96	1.17
-316	0.42	0.53	0.42	0.53	0.96	1.17
-315	0.42	0.53	0.42	0.53	0.96	1.17
-314	0.42	0.53	0.42	0.53	0.96	1.17
-313	0.42	0.53	0.42	0.53	0.96	1.17
-312	0.42	0.53	0.42	0.53	0.96	1.17

Dist (ft) from duct bank centerline	138-kV Onshore (Parallel Roads)		138-kV Onshore (Parallel Railway)		69-kV Onshore (Parallel Railway)	
	132 MW Load	WNC Rating	132 MW Load	WNC Rating	132 MW Load	WNC Rating
-311	0.42	0.53	0.42	0.53	0.96	1.17
-310	0.42	0.53	0.42	0.53	0.96	1.17
-309	0.42	0.53	0.42	0.53	0.96	1.17
-308	0.42	0.53	0.42	0.53	0.96	1.17
-307	0.42	0.53	0.42	0.53	0.96	1.17
-306	0.42	0.53	0.42	0.53	0.96	1.17
-305	0.42	0.53	0.42	0.53	0.96	1.17
-304	0.42	0.53	0.42	0.53	0.96	1.17
-303	0.42	0.53	0.42	0.53	0.96	1.17
-302	0.42	0.53	0.42	0.53	0.96	1.17
-301	0.42	0.53	0.42	0.53	0.96	1.17
-300	0.42	0.53	0.42	0.53	0.96	1.17
-299	0.42	0.53	0.42	0.53	0.96	1.17
-298	0.42	0.53	0.42	0.53	0.96	1.17
-297	0.42	0.53	0.42	0.53	0.96	1.17
-296	0.42	0.53	0.42	0.53	0.96	1.17
-295	0.42	0.53	0.42	0.53	0.96	1.17
-294	0.42	0.53	0.42	0.53	0.96	1.17
-293	0.42	0.53	0.42	0.53	0.96	1.17
-292	0.42	0.53	0.42	0.53	0.96	1.17
-291	0.42	0.53	0.42	0.53	0.96	1.17
-290	0.42	0.53	0.42	0.53	0.96	1.17
-289	0.42	0.53	0.42	0.53	0.96	1.17
-288	0.42	0.53	0.42	0.53	0.96	1.17
-287	0.42	0.53	0.42	0.53	0.96	1.17
-286	0.42	0.53	0.42	0.53	0.96	1.17
-285	0.42	0.53	0.42	0.53	0.96	1.17
-284	0.42	0.53	0.42	0.53	0.96	1.17
-283	0.42	0.53	0.42	0.53	0.96	1.17
-282	0.42	0.53	0.42	0.53	0.96	1.17
-281	0.42	0.53	0.42	0.53	0.96	1.17
-280	0.42	0.53	0.42	0.53	0.96	1.17
-279	0.42	0.53	0.42	0.53	0.96	1.17
-278	0.42	0.53	0.42	0.53	0.96	1.17
-277	0.42	0.53	0.42	0.53	0.96	1.17
-276	0.42	0.53	0.42	0.53	0.96	1.17
-275	0.42	0.53	0.42	0.53	0.96	1.17
-274	0.42	0.53	0.42	0.53	0.96	1.17

Dist (ft) from duct bank centerline	138-kV Onshore (Parallel Roads)		138-kV Onshore (Parallel Railway)		69-kV Onshore (Parallel Railway)	
	132 MW Load	WNC Rating	132 MW Load	WNC Rating	132 MW Load	WNC Rating
-273	0.42	0.53	0.42	0.53	0.96	1.17
-272	0.42	0.53	0.42	0.53	0.96	1.17
-271	0.42	0.53	0.42	0.53	0.96	1.17
-270	0.42	0.53	0.42	0.53	0.96	1.17
-269	0.42	0.53	0.42	0.53	0.96	1.17
-268	0.42	0.53	0.42	0.53	0.96	1.17
-267	0.42	0.53	0.42	0.53	0.96	1.17
-266	0.42	0.53	0.42	0.53	0.96	1.17
-265	0.42	0.53	0.42	0.53	0.96	1.17
-264	0.42	0.53	0.42	0.53	0.96	1.17
-263	0.42	0.53	0.42	0.53	0.96	1.17
-262	0.42	0.53	0.42	0.53	0.96	1.17
-261	0.42	0.53	0.42	0.53	0.96	1.17
-260	0.42	0.53	0.42	0.53	0.96	1.17
-259	0.42	0.53	0.42	0.53	0.96	1.17
-258	0.42	0.53	0.42	0.53	0.96	1.17
-257	0.42	0.53	0.42	0.53	0.96	1.17
-256	0.42	0.53	0.42	0.53	0.96	1.17
-255	0.42	0.53	0.42	0.53	0.96	1.17
-254	0.42	0.53	0.42	0.53	0.96	1.17
-253	0.42	0.53	0.42	0.53	0.96	1.17
-252	0.42	0.53	0.42	0.53	0.96	1.17
-251	0.42	0.53	0.42	0.53	0.96	1.17
-250	0.42	0.53	0.42	0.53	0.96	1.17
-249	0.42	0.53	0.42	0.53	0.96	1.17
-248	0.42	0.53	0.42	0.53	0.96	1.17
-247	0.42	0.53	0.42	0.53	0.96	1.17
-246	0.42	0.53	0.42	0.53	0.96	1.17
-245	0.42	0.53	0.42	0.53	0.96	1.17
-244	0.42	0.53	0.42	0.53	0.96	1.17
-243	0.42	0.53	0.42	0.53	0.96	1.17
-242	0.42	0.53	0.42	0.53	0.96	1.17
-241	0.42	0.53	0.42	0.53	0.96	1.17
-240	0.42	0.53	0.42	0.53	0.96	1.17
-239	0.42	0.53	0.42	0.53	0.96	1.17
-238	0.42	0.53	0.42	0.53	0.96	1.17
-237	0.42	0.53	0.42	0.53	0.96	1.17
-236	0.42	0.53	0.42	0.53	0.96	1.17

Dist (ft) from duct bank centerline	138-kV Onshore (Parallel Roads)		138-kV Onshore (Parallel Railway)		69-kV Onshore (Parallel Railway)	
	132 MW Load	WNC Rating	132 MW Load	WNC Rating	132 MW Load	WNC Rating
-235	0.42	0.53	0.42	0.53	0.96	1.17
-234	0.42	0.53	0.42	0.53	0.96	1.17
-233	0.42	0.53	0.42	0.53	0.96	1.17
-232	0.42	0.53	0.42	0.53	0.96	1.17
-231	0.42	0.53	0.42	0.53	0.96	1.17
-230	0.42	0.53	0.42	0.53	0.96	1.17
-229	0.42	0.53	0.42	0.53	0.96	1.17
-228	0.42	0.53	0.42	0.53	0.96	1.17
-227	0.42	0.53	0.42	0.53	0.96	1.17
-226	0.42	0.53	0.42	0.53	0.96	1.17
-225	0.42	0.53	0.42	0.53	0.96	1.17
-224	0.42	0.53	0.42	0.53	0.96	1.17
-223	0.42	0.53	0.42	0.53	0.96	1.17
-222	0.42	0.53	0.42	0.53	0.96	1.17
-221	0.42	0.53	0.42	0.53	0.96	1.17
-220	0.42	0.53	0.42	0.53	0.96	1.17
-219	0.42	0.53	0.42	0.53	0.96	1.17
-218	0.42	0.53	0.42	0.53	0.96	1.17
-217	0.42	0.53	0.42	0.53	0.96	1.17
-216	0.42	0.53	0.42	0.53	0.96	1.17
-215	0.42	0.53	0.42	0.53	0.96	1.17
-214	0.42	0.53	0.42	0.53	0.96	1.17
-213	0.42	0.53	0.42	0.53	0.96	1.17
-212	0.42	0.53	0.42	0.53	0.96	1.17
-211	0.42	0.53	0.42	0.53	0.96	1.17
-210	0.42	0.53	0.42	0.53	0.96	1.17
-209	0.42	0.53	0.42	0.53	0.96	1.17
-208	0.42	0.53	0.42	0.53	0.96	1.17
-207	0.42	0.53	0.42	0.53	0.96	1.17
-206	0.42	0.53	0.42	0.53	0.96	1.17
-205	0.42	0.53	0.42	0.53	0.96	1.17
-204	0.42	0.53	0.42	0.53	0.96	1.17
-203	0.42	0.53	0.42	0.53	0.96	1.17
-202	0.42	0.53	0.42	0.53	0.96	1.17
-201	0.42	0.53	0.42	0.53	0.96	1.17
-200	0.42	0.53	0.42	0.53	0.96	1.17
-199	0.42	0.53	0.42	0.53	0.96	1.17
-198	0.42	0.53	0.42	0.53	0.96	1.17

Dist (ft) from duct bank centerline	138-kV Onshore (Parallel Roads)		138-kV Onshore (Parallel Railway)		69-kV Onshore (Parallel Railway)	
	132 MW Load	WNC Rating	132 MW Load	WNC Rating	132 MW Load	WNC Rating
-197	0.42	0.53	0.42	0.53	0.96	1.17
-196	0.42	0.53	0.42	0.53	0.96	1.17
-195	0.42	0.53	0.42	0.53	0.96	1.17
-194	0.42	0.53	0.42	0.53	0.96	1.17
-193	0.42	0.53	0.42	0.53	0.96	1.17
-192	0.42	0.53	0.42	0.53	0.96	1.17
-191	0.42	0.53	0.42	0.53	0.96	1.17
-190	0.42	0.53	0.42	0.53	0.96	1.17
-189	0.42	0.53	0.42	0.53	0.96	1.17
-188	0.42	0.53	0.42	0.53	0.96	1.17
-187	0.42	0.53	0.42	0.53	0.96	1.17
-186	0.42	0.53	0.42	0.53	0.96	1.17
-185	0.42	0.53	0.42	0.53	0.96	1.17
-184	0.42	0.53	0.42	0.53	0.96	1.17
-183	0.42	0.53	0.42	0.53	0.96	1.17
-182	0.42	0.53	0.42	0.53	0.96	1.17
-181	0.42	0.53	0.42	0.53	0.96	1.17
-180	0.42	0.53	0.42	0.53	0.96	1.17
-179	0.42	0.53	0.42	0.53	0.96	1.17
-178	0.42	0.53	0.42	0.53	0.96	1.17
-177	0.42	0.53	0.42	0.53	0.96	1.17
-176	0.42	0.53	0.42	0.53	0.96	1.17
-175	0.42	0.53	0.42	0.53	0.96	1.17
-174	0.42	0.53	0.42	0.53	0.96	1.17
-173	0.42	0.53	0.42	0.53	0.96	1.17
-172	0.42	0.53	0.42	0.53	0.96	1.17
-171	0.42	0.53	0.42	0.53	0.96	1.17
-170	0.42	0.53	0.42	0.53	0.96	1.17
-169	0.42	0.53	0.42	0.53	0.96	1.17
-168	0.42	0.53	0.42	0.53	0.96	1.17
-167	0.42	0.53	0.42	0.53	0.96	1.17
-166	0.42	0.53	0.42	0.53	0.96	1.17
-165	0.42	0.53	0.42	0.53	0.96	1.17
-164	0.42	0.53	0.42	0.53	0.96	1.17
-163	0.42	0.53	0.42	0.53	0.96	1.17
-162	0.42	0.53	0.42	0.53	0.96	1.17
-161	0.42	0.53	0.42	0.53	0.96	1.17
-160	0.42	0.53	0.42	0.53	0.96	1.17

Dist (ft) from duct bank centerline	138-kV Onshore (Parallel Roads)		138-kV Onshore (Parallel Railway)		69-kV Onshore (Parallel Railway)	
	132 MW Load	WNC Rating	132 MW Load	WNC Rating	132 MW Load	WNC Rating
-159	0.42	0.53	0.42	0.53	0.96	1.17
-158	0.42	0.53	0.42	0.53	0.96	1.17
-157	0.42	0.53	0.42	0.53	0.96	1.17
-156	0.42	0.53	0.42	0.53	0.96	1.17
-155	0.42	0.53	0.42	0.53	0.96	1.17
-154	0.42	0.53	0.42	0.53	0.96	1.17
-153	0.42	0.53	0.42	0.53	0.96	1.17
-152	0.42	0.53	0.42	0.53	0.96	1.17
-151	0.42	0.53	0.42	0.53	0.96	1.17
-150	0.42	0.53	0.42	0.53	0.96	1.17
-149	0.42	0.53	0.42	0.53	0.96	1.17
-148	0.42	0.53	0.42	0.53	0.96	1.17
-147	0.42	0.53	0.42	0.53	0.96	1.17
-146	0.42	0.53	0.42	0.53	0.96	1.17
-145	0.42	0.53	0.42	0.53	0.96	1.17
-144	0.42	0.53	0.42	0.53	0.96	1.17
-143	0.42	0.53	0.42	0.53	0.96	1.17
-142	0.42	0.53	0.42	0.53	0.96	1.17
-141	0.42	0.53	0.42	0.53	0.96	1.17
-140	0.42	0.53	0.42	0.53	0.96	1.17
-139	0.42	0.53	0.42	0.53	0.96	1.17
-138	0.42	0.53	0.42	0.53	0.96	1.17
-137	0.42	0.53	0.42	0.53	0.96	1.17
-136	0.42	0.53	0.42	0.53	0.96	1.17
-135	0.42	0.53	0.42	0.53	0.96	1.17
-134	0.42	0.53	0.42	0.53	0.96	1.17
-133	0.42	0.53	0.42	0.53	0.96	1.17
-132	0.42	0.53	0.42	0.53	0.96	1.17
-131	0.42	0.53	0.42	0.53	0.96	1.17
-130	0.42	0.53	0.42	0.53	0.96	1.17
-129	0.42	0.53	0.42	0.53	0.96	1.17
-128	0.42	0.53	0.42	0.53	0.96	1.17
-127	0.42	0.53	0.42	0.53	0.96	1.17
-126	0.42	0.53	0.42	0.53	0.96	1.17
-125	0.42	0.53	0.42	0.53	0.96	1.17
-124	0.42	0.53	0.42	0.53	0.96	1.17
-123	0.42	0.53	0.42	0.53	0.96	1.17
-122	0.42	0.53	0.42	0.53	0.96	1.17

Dist (ft) from duct bank centerline	138-kV Onshore (Parallel Roads)		138-kV Onshore (Parallel Railway)		69-kV Onshore (Parallel Railway)	
	132 MW Load	WNC Rating	132 MW Load	WNC Rating	132 MW Load	WNC Rating
-121	0.42	0.53	0.42	0.53	0.96	1.17
-120	0.42	0.53	0.42	0.53	0.96	1.17
-119	0.42	0.53	0.42	0.53	0.96	1.17
-118	0.42	0.53	0.42	0.53	0.96	1.17
-117	0.42	0.53	0.42	0.53	0.96	1.17
-116	0.42	0.53	0.42	0.53	0.96	1.17
-115	0.42	0.53	0.42	0.53	0.96	1.17
-114	0.42	0.53	0.42	0.53	0.96	1.17
-113	0.42	0.53	0.42	0.53	0.96	1.17
-112	0.42	0.53	0.42	0.53	0.96	1.17
-111	0.42	0.53	0.42	0.53	0.96	1.17
-110	0.42	0.53	0.42	0.53	0.96	1.17
-109	0.42	0.53	0.42	0.53	0.96	1.17
-108	0.42	0.53	0.42	0.53	0.96	1.17
-107	0.42	0.53	0.42	0.53	0.96	1.17
-106	0.42	0.53	0.42	0.53	0.96	1.17
-105	0.42	0.53	0.42	0.53	0.96	1.17
-104	0.42	0.53	0.42	0.53	0.96	1.17
-103	0.42	0.53	0.42	0.53	0.96	1.17
-102	0.42	0.53	0.42	0.53	0.96	1.17
-101	0.42	0.53	0.42	0.53	0.96	1.17
-100	0.42	0.53	0.42	0.53	0.96	1.17
-99	0.43	0.54	0.43	0.54	0.98	1.19
-98	0.44	0.55	0.44	0.55	1.00	1.22
-97	0.45	0.56	0.45	0.56	1.02	1.24
-96	0.46	0.58	0.46	0.58	1.04	1.27
-95	0.47	0.59	0.47	0.59	1.06	1.29
-94	0.48	0.60	0.48	0.60	1.09	1.32
-93	0.49	0.61	0.49	0.61	1.11	1.35
-92	0.50	0.63	0.50	0.63	1.13	1.38
-91	0.51	0.64	0.51	0.64	1.16	1.41
-90	0.52	0.66	0.52	0.65	1.19	1.44
-89	0.54	0.67	0.54	0.67	1.21	1.47
-88	0.55	0.69	0.55	0.68	1.24	1.51
-87	0.56	0.70	0.56	0.70	1.27	1.54
-86	0.57	0.72	0.57	0.72	1.30	1.58
-85	0.59	0.73	0.59	0.73	1.33	1.62
-84	0.60	0.75	0.60	0.75	1.36	1.66

Dist (ft) from duct bank centerline	138-kV Onshore (Parallel Roads)		138-kV Onshore (Parallel Railway)		69-kV Onshore (Parallel Railway)	
	132 MW Load	WNC Rating	132 MW Load	WNC Rating	132 MW Load	WNC Rating
-83	0.62	0.77	0.62	0.77	1.39	1.70
-82	0.63	0.79	0.63	0.79	1.43	1.74
-81	0.65	0.81	0.65	0.81	1.46	1.78
-80	0.66	0.83	0.66	0.83	1.50	1.82
-79	0.68	0.85	0.68	0.85	1.54	1.87
-78	0.70	0.87	0.70	0.87	1.58	1.92
-77	0.71	0.89	0.71	0.89	1.62	1.97
-76	0.73	0.92	0.73	0.92	1.66	2.02
-75	0.75	0.94	0.75	0.94	1.71	2.08
-74	0.77	0.97	0.77	0.97	1.75	2.13
-73	0.79	0.99	0.79	0.99	1.80	2.19
-72	0.82	1.02	0.82	1.02	1.85	2.25
-71	0.84	1.05	0.84	1.05	1.90	2.32
-70	0.86	1.08	0.86	1.08	1.96	2.38
-69	0.89	1.11	0.89	1.11	2.02	2.45
-68	0.92	1.14	0.91	1.14	2.07	2.52
-67	0.94	1.18	0.94	1.18	2.14	2.60
-66	0.97	1.21	0.97	1.21	2.20	2.68
-65	1.00	1.25	1.00	1.25	2.27	2.76
-64	1.03	1.29	1.03	1.29	2.34	2.85
-63	1.06	1.33	1.06	1.33	2.42	2.94
-62	1.10	1.37	1.10	1.37	2.49	3.03
-61	1.14	1.42	1.13	1.42	2.58	3.13
-60	1.17	1.47	1.17	1.46	2.66	3.24
-59	1.21	1.52	1.21	1.51	2.75	3.35
-58	1.25	1.57	1.25	1.57	2.85	3.46
-57	1.30	1.62	1.30	1.62	2.95	3.59
-56	1.34	1.68	1.34	1.68	3.05	3.71
-55	1.39	1.74	1.39	1.74	3.17	3.85
-54	1.44	1.81	1.44	1.80	3.28	3.99
-53	1.50	1.87	1.50	1.87	3.41	4.14
-52	1.56	1.95	1.55	1.94	3.54	4.30
-51	1.62	2.02	1.61	2.02	3.68	4.47
-50	1.68	2.10	1.68	2.10	3.83	4.65
-49	1.75	2.19	1.75	2.18	3.98	4.84
-48	1.82	2.28	1.82	2.27	4.15	5.04
-47	1.90	2.37	1.90	2.37	4.32	5.26
-46	1.98	2.48	1.98	2.47	4.51	5.49

Dist (ft) from duct bank centerline	138-kV Onshore (Parallel Roads)		138-kV Onshore (Parallel Railway)		69-kV Onshore (Parallel Railway)	
	132 MW Load	WNC Rating	132 MW Load	WNC Rating	132 MW Load	WNC Rating
-45	2.07	2.59	2.06	2.58	4.71	5.73
-44	2.16	2.70	2.16	2.70	4.93	5.99
-43	2.26	2.83	2.26	2.82	5.16	6.27
-42	2.37	2.96	2.36	2.95	5.40	6.57
-41	2.48	3.10	2.48	3.10	5.66	6.89
-40	2.61	3.26	2.60	3.25	5.95	7.23
-39	2.74	3.42	2.73	3.41	6.25	7.60
-38	2.88	3.60	2.87	3.59	6.58	8.00
-37	3.03	3.79	3.02	3.78	6.93	8.43
-36	3.20	4.00	3.19	3.99	7.32	8.90
-35	3.38	4.23	3.37	4.21	7.73	9.40
-34	3.58	4.47	3.56	4.45	8.18	9.95
-33	3.79	4.74	3.77	4.72	8.67	10.55
-32	4.02	5.03	4.00	5.00	9.21	11.20
-31	4.28	5.35	4.25	5.32	9.80	11.92
-30	4.55	5.69	4.53	5.66	10.44	12.70
-29	4.86	6.08	4.83	6.04	11.15	13.57
-28	5.20	6.50	5.17	6.46	11.94	14.52
-27	5.57	6.97	5.53	6.92	12.80	15.57
-26	5.99	7.48	5.94	7.43	13.77	16.74
-25	6.45	8.06	6.40	8.00	14.84	18.05
-24	6.96	8.71	6.91	8.63	16.04	19.51
-23	7.54	9.43	7.47	9.34	17.39	21.15
-22	8.20	10.24	8.11	10.14	18.91	23.00
-21	8.93	11.17	8.84	11.05	20.64	25.10
-20	9.77	12.22	9.66	12.07	22.60	27.49
-19	10.73	13.41	10.59	13.24	24.85	30.23
-18	11.83	14.79	11.66	14.58	27.44	33.37
-17	13.11	16.38	12.90	16.12	30.43	37.01
-16	14.58	18.23	14.33	17.91	33.91	41.25
-15	16.31	20.39	15.99	19.99	37.99	46.21
-14	18.35	22.93	17.94	22.43	42.80	52.06
-13	20.76	25.94	20.24	25.30	48.50	58.99
-12	23.63	29.54	22.96	28.71	55.31	67.27
-11	27.08	33.84	26.21	32.76	63.49	77.22
-10	31.24	39.05	30.09	37.61	73.36	89.22
-9	36.28	45.35	34.74	43.43	85.31	103.75
-8	42.41	53.01	40.32	50.40	99.77	121.35

Dist (ft) from duct bank centerline	138-kV Onshore (Parallel Roads)		138-kV Onshore (Parallel Railway)		69-kV Onshore (Parallel Railway)	
	132 MW Load	WNC Rating	132 MW Load	WNC Rating	132 MW Load	WNC Rating
-7	49.83	62.29	46.98	58.72	117.18	142.52
-6	58.75	73.44	54.82	68.53	137.85	167.66
-5	69.25	86.56	63.86	79.82	161.68	196.64
-4	81.13	101.41	73.84	92.29	187.76	228.37
-3	93.68	117.10	84.09	105.12	213.88	260.14
-2	105.43	131.79	93.44	116.80	236.27	287.37
-1	114.18	142.72	100.23	125.29	250.31	304.45
0	117.67	147.09	102.90	128.62	252.43	307.02
1	114.83	143.54	100.71	125.88	242.02	294.36
2	106.46	133.08	94.20	117.76	221.87	269.85
3	94.76	118.45	84.93	106.16	196.49	238.98
4	82.05	102.56	74.58	93.22	170.07	206.85
5	69.95	87.43	64.45	80.56	145.34	176.78
6	59.25	74.07	55.26	69.08	123.60	150.33
7	50.18	62.73	47.29	59.11	105.14	127.88
8	42.65	53.31	40.54	50.68	89.75	109.16
9	36.45	45.56	34.90	43.62	77.03	93.69
10	31.35	39.19	30.20	37.75	66.52	80.91
11	27.16	33.94	26.29	32.86	57.83	70.34
12	23.68	29.61	23.02	28.78	50.60	61.55
13	20.80	25.99	20.28	25.35	44.56	54.20
14	18.37	22.97	17.97	22.47	39.48	48.02
15	16.33	20.42	16.01	20.02	35.18	42.79
16	14.60	18.25	14.34	17.93	31.52	38.33
17	13.12	16.40	12.91	16.14	28.37	34.51
18	11.84	14.80	11.67	14.59	25.66	31.21
19	10.74	13.42	10.60	13.25	23.31	28.35
20	9.78	12.22	9.66	12.08	21.26	25.85
21	8.94	11.17	8.84	11.05	19.46	23.66
22	8.20	10.25	8.12	10.15	17.87	21.74
23	7.55	9.43	7.48	9.35	16.47	20.03
24	6.97	8.71	6.91	8.63	15.22	18.51
25	6.45	8.06	6.40	8.00	14.11	17.16
26	5.99	7.48	5.94	7.43	13.11	15.94
27	5.57	6.97	5.54	6.92	12.21	14.85
28	5.20	6.50	5.17	6.46	11.40	13.87
29	4.86	6.08	4.83	6.04	10.67	12.98
30	4.56	5.69	4.53	5.66	10.00	12.17

Dist (ft) from duct bank centerline	138-kV Onshore (Parallel Roads)		138-kV Onshore (Parallel Railway)		69-kV Onshore (Parallel Railway)	
	132 MW Load	WNC Rating	132 MW Load	WNC Rating	132 MW Load	WNC Rating
31	4.28	5.35	4.25	5.32	9.40	11.43
32	4.02	5.03	4.00	5.00	8.85	10.76
33	3.79	4.74	3.77	4.72	8.34	10.14
34	3.58	4.47	3.56	4.45	7.88	9.58
35	3.38	4.23	3.37	4.21	7.45	9.06
36	3.20	4.00	3.19	3.99	7.06	8.58
37	3.03	3.79	3.02	3.78	6.69	8.14
38	2.88	3.60	2.87	3.59	6.36	7.73
39	2.74	3.42	2.73	3.41	6.04	7.35
40	2.61	3.26	2.60	3.25	5.76	7.00
41	2.48	3.10	2.48	3.09	5.49	6.67
42	2.37	2.96	2.36	2.95	5.23	6.37
43	2.26	2.83	2.26	2.82	5.00	6.08
44	2.16	2.70	2.16	2.70	4.78	5.82
45	2.07	2.59	2.06	2.58	4.58	5.57
46	1.98	2.48	1.98	2.47	4.38	5.33
47	1.90	2.37	1.90	2.37	4.20	5.11
48	1.82	2.28	1.82	2.27	4.03	4.91
49	1.75	2.19	1.75	2.18	3.88	4.71
50	1.68	2.10	1.68	2.10	3.73	4.53
51	1.62	2.02	1.61	2.02	3.58	4.36
52	1.56	1.95	1.55	1.94	3.45	4.20
53	1.50	1.87	1.50	1.87	3.32	4.04
54	1.44	1.81	1.44	1.80	3.20	3.90
55	1.39	1.74	1.39	1.74	3.09	3.76
56	1.34	1.68	1.34	1.68	2.98	3.63
57	1.30	1.62	1.30	1.62	2.88	3.50
58	1.25	1.57	1.25	1.57	2.78	3.39
59	1.21	1.52	1.21	1.51	2.69	3.27
60	1.17	1.47	1.17	1.46	2.60	3.17
61	1.14	1.42	1.13	1.42	2.52	3.07
62	1.10	1.37	1.10	1.37	2.44	2.97
63	1.06	1.33	1.06	1.33	2.37	2.88
64	1.03	1.29	1.03	1.29	2.29	2.79
65	1.00	1.25	1.00	1.25	2.22	2.70
66	0.97	1.21	0.97	1.21	2.16	2.62
67	0.94	1.18	0.94	1.18	2.09	2.55
68	0.92	1.14	0.91	1.14	2.03	2.47

Dist (ft) from duct bank centerline	138-kV Onshore (Parallel Roads)		138-kV Onshore (Parallel Railway)		69-kV Onshore (Parallel Railway)	
	132 MW Load	WNC Rating	132 MW Load	WNC Rating	132 MW Load	WNC Rating
69	0.89	1.11	0.89	1.11	1.98	2.40
70	0.86	1.08	0.86	1.08	1.92	2.34
71	0.84	1.05	0.84	1.05	1.87	2.27
72	0.82	1.02	0.82	1.02	1.82	2.21
73	0.79	0.99	0.79	0.99	1.77	2.15
74	0.77	0.97	0.77	0.97	1.72	2.09
75	0.75	0.94	0.75	0.94	1.68	2.04
76	0.73	0.92	0.73	0.92	1.63	1.99
77	0.71	0.89	0.71	0.89	1.59	1.94
78	0.70	0.87	0.70	0.87	1.55	1.89
79	0.68	0.85	0.68	0.85	1.51	1.84
80	0.66	0.83	0.66	0.83	1.48	1.79
81	0.65	0.81	0.65	0.81	1.44	1.75
82	0.63	0.79	0.63	0.79	1.40	1.71
83	0.62	0.77	0.62	0.77	1.37	1.67
84	0.60	0.75	0.60	0.75	1.34	1.63
85	0.59	0.73	0.59	0.73	1.31	1.59
86	0.57	0.72	0.57	0.72	1.28	1.55
87	0.56	0.70	0.56	0.70	1.25	1.52
88	0.55	0.69	0.55	0.68	1.22	1.49
89	0.54	0.67	0.54	0.67	1.19	1.45
90	0.52	0.66	0.52	0.65	1.17	1.42
91	0.51	0.64	0.51	0.64	1.14	1.39
92	0.50	0.63	0.50	0.63	1.12	1.36
93	0.49	0.61	0.49	0.61	1.09	1.33
94	0.48	0.60	0.48	0.60	1.07	1.30
95	0.47	0.59	0.47	0.59	1.05	1.28
96	0.46	0.58	0.46	0.58	1.03	1.25
97	0.45	0.56	0.45	0.56	1.01	1.22
98	0.44	0.55	0.44	0.55	0.99	1.20
99	0.43	0.54	0.43	0.54	0.97	1.18
100	0.42	0.53	0.42	0.53	0.95	1.15
101	0.42	0.53	0.42	0.53	0.95	1.15
102	0.42	0.53	0.42	0.53	0.95	1.15
103	0.42	0.53	0.42	0.53	0.95	1.15
104	0.42	0.53	0.42	0.53	0.95	1.15
105	0.42	0.53	0.42	0.53	0.95	1.15
106	0.42	0.53	0.42	0.53	0.95	1.15

Dist (ft) from duct bank centerline	138-kV Onshore (Parallel Roads)		138-kV Onshore (Parallel Railway)		69-kV Onshore (Parallel Railway)	
	132 MW Load	WNC Rating	132 MW Load	WNC Rating	132 MW Load	WNC Rating
107	0.42	0.53	0.42	0.53	0.95	1.15
108	0.42	0.53	0.42	0.53	0.95	1.15
109	0.42	0.53	0.42	0.53	0.95	1.15
110	0.42	0.53	0.42	0.53	0.95	1.15
111	0.42	0.53	0.42	0.53	0.95	1.15
112	0.42	0.53	0.42	0.53	0.95	1.15
113	0.42	0.53	0.42	0.53	0.95	1.15
114	0.42	0.53	0.42	0.53	0.95	1.15
115	0.42	0.53	0.42	0.53	0.95	1.15
116	0.42	0.53	0.42	0.53	0.95	1.15
117	0.42	0.53	0.42	0.53	0.95	1.15
118	0.42	0.53	0.42	0.53	0.95	1.15
119	0.42	0.53	0.42	0.53	0.95	1.15
120	0.42	0.53	0.42	0.53	0.95	1.15
121	0.42	0.53	0.42	0.53	0.95	1.15
122	0.42	0.53	0.42	0.53	0.95	1.15
123	0.42	0.53	0.42	0.53	0.95	1.15
124	0.42	0.53	0.42	0.53	0.95	1.15
125	0.42	0.53	0.42	0.53	0.95	1.15
126	0.42	0.53	0.42	0.53	0.95	1.15
127	0.42	0.53	0.42	0.53	0.95	1.15
128	0.42	0.53	0.42	0.53	0.95	1.15
129	0.42	0.53	0.42	0.53	0.95	1.15
130	0.42	0.53	0.42	0.53	0.95	1.15
131	0.42	0.53	0.42	0.53	0.95	1.15
132	0.42	0.53	0.42	0.53	0.95	1.15
133	0.42	0.53	0.42	0.53	0.95	1.15
134	0.42	0.53	0.42	0.53	0.95	1.15
135	0.42	0.53	0.42	0.53	0.95	1.15
136	0.42	0.53	0.42	0.53	0.95	1.15
137	0.42	0.53	0.42	0.53	0.95	1.15
138	0.42	0.53	0.42	0.53	0.95	1.15
139	0.42	0.53	0.42	0.53	0.95	1.15
140	0.42	0.53	0.42	0.53	0.95	1.15
141	0.42	0.53	0.42	0.53	0.95	1.15
142	0.42	0.53	0.42	0.53	0.95	1.15
143	0.42	0.53	0.42	0.53	0.95	1.15
144	0.42	0.53	0.42	0.53	0.95	1.15

Dist (ft) from duct bank centerline	138-kV Onshore (Parallel Roads)		138-kV Onshore (Parallel Railway)		69-kV Onshore (Parallel Railway)	
	132 MW Load	WNC Rating	132 MW Load	WNC Rating	132 MW Load	WNC Rating
145	0.42	0.53	0.42	0.53	0.95	1.15
146	0.42	0.53	0.42	0.53	0.95	1.15
147	0.42	0.53	0.42	0.53	0.95	1.15
148	0.42	0.53	0.42	0.53	0.95	1.15
149	0.42	0.53	0.42	0.53	0.95	1.15
150	0.42	0.53	0.42	0.53	0.95	1.15
151	0.42	0.53	0.42	0.53	0.95	1.15
152	0.42	0.53	0.42	0.53	0.95	1.15
153	0.42	0.53	0.42	0.53	0.95	1.15
154	0.42	0.53	0.42	0.53	0.95	1.15
155	0.42	0.53	0.42	0.53	0.95	1.15
156	0.42	0.53	0.42	0.53	0.95	1.15
157	0.42	0.53	0.42	0.53	0.95	1.15
158	0.42	0.53	0.42	0.53	0.95	1.15
159	0.42	0.53	0.42	0.53	0.95	1.15
160	0.42	0.53	0.42	0.53	0.95	1.15
161	0.42	0.53	0.42	0.53	0.95	1.15
162	0.42	0.53	0.42	0.53	0.95	1.15
163	0.42	0.53	0.42	0.53	0.95	1.15
164	0.42	0.53	0.42	0.53	0.95	1.15
165	0.42	0.53	0.42	0.53	0.95	1.15
166	0.42	0.53	0.42	0.53	0.95	1.15
167	0.42	0.53	0.42	0.53	0.95	1.15
168	0.42	0.53	0.42	0.53	0.95	1.15
169	0.42	0.53	0.42	0.53	0.95	1.15
170	0.42	0.53	0.42	0.53	0.95	1.15
171	0.42	0.53	0.42	0.53	0.95	1.15
172	0.42	0.53	0.42	0.53	0.95	1.15
173	0.42	0.53	0.42	0.53	0.95	1.15
174	0.42	0.53	0.42	0.53	0.95	1.15
175	0.42	0.53	0.42	0.53	0.95	1.15
176	0.42	0.53	0.42	0.53	0.95	1.15
177	0.42	0.53	0.42	0.53	0.95	1.15
178	0.42	0.53	0.42	0.53	0.95	1.15
179	0.42	0.53	0.42	0.53	0.95	1.15
180	0.42	0.53	0.42	0.53	0.95	1.15
181	0.42	0.53	0.42	0.53	0.95	1.15
182	0.42	0.53	0.42	0.53	0.95	1.15

Dist (ft) from duct bank centerline	138-kV Onshore (Parallel Roads)		138-kV Onshore (Parallel Railway)		69-kV Onshore (Parallel Railway)	
	132 MW Load	WNC Rating	132 MW Load	WNC Rating	132 MW Load	WNC Rating
183	0.42	0.53	0.42	0.53	0.95	1.15
184	0.42	0.53	0.42	0.53	0.95	1.15
185	0.42	0.53	0.42	0.53	0.95	1.15
186	0.42	0.53	0.42	0.53	0.95	1.15
187	0.42	0.53	0.42	0.53	0.95	1.15
188	0.42	0.53	0.42	0.53	0.95	1.15
189	0.42	0.53	0.42	0.53	0.95	1.15
190	0.42	0.53	0.42	0.53	0.95	1.15
191	0.42	0.53	0.42	0.53	0.95	1.15
192	0.42	0.53	0.42	0.53	0.95	1.15
193	0.42	0.53	0.42	0.53	0.95	1.15
194	0.42	0.53	0.42	0.53	0.95	1.15
195	0.42	0.53	0.42	0.53	0.95	1.15
196	0.42	0.53	0.42	0.53	0.95	1.15
197	0.42	0.53	0.42	0.53	0.95	1.15
198	0.42	0.53	0.42	0.53	0.95	1.15
199	0.42	0.53	0.42	0.53	0.95	1.15
200	0.42	0.53	0.42	0.53	0.95	1.15
201	0.42	0.53	0.42	0.53	0.95	1.15
202	0.42	0.53	0.42	0.53	0.95	1.15
203	0.42	0.53	0.42	0.53	0.95	1.15
204	0.42	0.53	0.42	0.53	0.95	1.15
205	0.42	0.53	0.42	0.53	0.95	1.15
206	0.42	0.53	0.42	0.53	0.95	1.15
207	0.42	0.53	0.42	0.53	0.95	1.15
208	0.42	0.53	0.42	0.53	0.95	1.15
209	0.42	0.53	0.42	0.53	0.95	1.15
210	0.42	0.53	0.42	0.53	0.95	1.15
211	0.42	0.53	0.42	0.53	0.95	1.15
212	0.42	0.53	0.42	0.53	0.95	1.15
213	0.42	0.53	0.42	0.53	0.95	1.15
214	0.42	0.53	0.42	0.53	0.95	1.15
215	0.42	0.53	0.42	0.53	0.95	1.15
216	0.42	0.53	0.42	0.53	0.95	1.15
217	0.42	0.53	0.42	0.53	0.95	1.15
218	0.42	0.53	0.42	0.53	0.95	1.15
219	0.42	0.53	0.42	0.53	0.95	1.15
220	0.42	0.53	0.42	0.53	0.95	1.15

Dist (ft) from duct bank centerline	138-kV Onshore (Parallel Roads)		138-kV Onshore (Parallel Railway)		69-kV Onshore (Parallel Railway)	
	132 MW Load	WNC Rating	132 MW Load	WNC Rating	132 MW Load	WNC Rating
221	0.42	0.53	0.42	0.53	0.95	1.15
222	0.42	0.53	0.42	0.53	0.95	1.15
223	0.42	0.53	0.42	0.53	0.95	1.15
224	0.42	0.53	0.42	0.53	0.95	1.15
225	0.42	0.53	0.42	0.53	0.95	1.15
226	0.42	0.53	0.42	0.53	0.95	1.15
227	0.42	0.53	0.42	0.53	0.95	1.15
228	0.42	0.53	0.42	0.53	0.95	1.15
229	0.42	0.53	0.42	0.53	0.95	1.15
230	0.42	0.53	0.42	0.53	0.95	1.15
231	0.42	0.53	0.42	0.53	0.95	1.15
232	0.42	0.53	0.42	0.53	0.95	1.15
233	0.42	0.53	0.42	0.53	0.95	1.15
234	0.42	0.53	0.42	0.53	0.95	1.15
235	0.42	0.53	0.42	0.53	0.95	1.15
236	0.42	0.53	0.42	0.53	0.95	1.15
237	0.42	0.53	0.42	0.53	0.95	1.15
238	0.42	0.53	0.42	0.53	0.95	1.15
239	0.42	0.53	0.42	0.53	0.95	1.15
240	0.42	0.53	0.42	0.53	0.95	1.15
241	0.42	0.53	0.42	0.53	0.95	1.15
242	0.42	0.53	0.42	0.53	0.95	1.15
243	0.42	0.53	0.42	0.53	0.95	1.15
244	0.42	0.53	0.42	0.53	0.95	1.15
245	0.42	0.53	0.42	0.53	0.95	1.15
246	0.42	0.53	0.42	0.53	0.95	1.15
247	0.42	0.53	0.42	0.53	0.95	1.15
248	0.42	0.53	0.42	0.53	0.95	1.15
249	0.42	0.53	0.42	0.53	0.95	1.15
250	0.42	0.53	0.42	0.53	0.95	1.15
251	0.42	0.53	0.42	0.53	0.95	1.15
252	0.42	0.53	0.42	0.53	0.95	1.15
253	0.42	0.53	0.42	0.53	0.95	1.15
254	0.42	0.53	0.42	0.53	0.95	1.15
255	0.42	0.53	0.42	0.53	0.95	1.15
256	0.42	0.53	0.42	0.53	0.95	1.15
257	0.42	0.53	0.42	0.53	0.95	1.15
258	0.42	0.53	0.42	0.53	0.95	1.15

Dist (ft) from duct bank centerline	138-kV Onshore (Parallel Roads)		138-kV Onshore (Parallel Railway)		69-kV Onshore (Parallel Railway)	
	132 MW Load	WNC Rating	132 MW Load	WNC Rating	132 MW Load	WNC Rating
259	0.42	0.53	0.42	0.53	0.95	1.15
260	0.42	0.53	0.42	0.53	0.95	1.15
261	0.42	0.53	0.42	0.53	0.95	1.15
262	0.42	0.53	0.42	0.53	0.95	1.15
263	0.42	0.53	0.42	0.53	0.95	1.15
264	0.42	0.53	0.42	0.53	0.95	1.15
265	0.42	0.53	0.42	0.53	0.95	1.15
266	0.42	0.53	0.42	0.53	0.95	1.15
267	0.42	0.53	0.42	0.53	0.95	1.15
268	0.42	0.53	0.42	0.53	0.95	1.15
269	0.42	0.53	0.42	0.53	0.95	1.15
270	0.42	0.53	0.42	0.53	0.95	1.15
271	0.42	0.53	0.42	0.53	0.95	1.15
272	0.42	0.53	0.42	0.53	0.95	1.15
273	0.42	0.53	0.42	0.53	0.95	1.15
274	0.42	0.53	0.42	0.53	0.95	1.15
275	0.42	0.53	0.42	0.53	0.95	1.15
276	0.42	0.53	0.42	0.53	0.95	1.15
277	0.42	0.53	0.42	0.53	0.95	1.15
278	0.42	0.53	0.42	0.53	0.95	1.15
279	0.42	0.53	0.42	0.53	0.95	1.15
280	0.42	0.53	0.42	0.53	0.95	1.15
281	0.42	0.53	0.42	0.53	0.95	1.15
282	0.42	0.53	0.42	0.53	0.95	1.15
283	0.42	0.53	0.42	0.53	0.95	1.15
284	0.42	0.53	0.42	0.53	0.95	1.15
285	0.42	0.53	0.42	0.53	0.95	1.15
286	0.42	0.53	0.42	0.53	0.95	1.15
287	0.42	0.53	0.42	0.53	0.95	1.15
288	0.42	0.53	0.42	0.53	0.95	1.15
289	0.42	0.53	0.42	0.53	0.95	1.15
290	0.42	0.53	0.42	0.53	0.95	1.15
291	0.42	0.53	0.42	0.53	0.95	1.15
292	0.42	0.53	0.42	0.53	0.95	1.15
293	0.42	0.53	0.42	0.53	0.95	1.15
294	0.42	0.53	0.42	0.53	0.95	1.15
295	0.42	0.53	0.42	0.53	0.95	1.15
296	0.42	0.53	0.42	0.53	0.95	1.15

Dist (ft) from duct bank centerline	138-kV Onshore (Parallel Roads)		138-kV Onshore (Parallel Railway)		69-kV Onshore (Parallel Railway)	
	132 MW Load	WNC Rating	132 MW Load	WNC Rating	132 MW Load	WNC Rating
297	0.42	0.53	0.42	0.53	0.95	1.15
298	0.42	0.53	0.42	0.53	0.95	1.15
299	0.42	0.53	0.42	0.53	0.95	1.15
300	0.42	0.53	0.42	0.53	0.95	1.15
301	0.42	0.53	0.42	0.53	0.95	1.15
302	0.42	0.53	0.42	0.53	0.95	1.15
303	0.42	0.53	0.42	0.53	0.95	1.15
304	0.42	0.53	0.42	0.53	0.95	1.15
305	0.42	0.53	0.42	0.53	0.95	1.15
306	0.42	0.53	0.42	0.53	0.95	1.15
307	0.42	0.53	0.42	0.53	0.95	1.15
308	0.42	0.53	0.42	0.53	0.95	1.15
309	0.42	0.53	0.42	0.53	0.95	1.15
310	0.42	0.53	0.42	0.53	0.95	1.15
311	0.42	0.53	0.42	0.53	0.95	1.15
312	0.42	0.53	0.42	0.53	0.95	1.15
313	0.42	0.53	0.42	0.53	0.95	1.15
314	0.42	0.53	0.42	0.53	0.95	1.15
315	0.42	0.53	0.42	0.53	0.95	1.15
316	0.42	0.53	0.42	0.53	0.95	1.15
317	0.42	0.53	0.42	0.53	0.95	1.15
318	0.42	0.53	0.42	0.53	0.95	1.15
319	0.42	0.53	0.42	0.53	0.95	1.15
320	0.42	0.53	0.42	0.53	0.95	1.15
321	0.42	0.53	0.42	0.53	0.95	1.15
322	0.42	0.53	0.42	0.53	0.95	1.15
323	0.42	0.53	0.42	0.53	0.95	1.15
324	0.42	0.53	0.42	0.53	0.95	1.15
325	0.42	0.53	0.42	0.53	0.95	1.15
326	0.42	0.53	0.42	0.53	0.95	1.15
327	0.42	0.53	0.42	0.53	0.95	1.15
328	0.42	0.53	0.42	0.53	0.95	1.15
329	0.42	0.53	0.42	0.53	0.95	1.15
330	0.42	0.53	0.42	0.53	0.95	1.15
331	0.42	0.53	0.42	0.53	0.95	1.15
332	0.42	0.53	0.42	0.53	0.95	1.15
333	0.42	0.53	0.42	0.53	0.95	1.15
334	0.42	0.53	0.42	0.53	0.95	1.15

Dist (ft) from duct bank centerline	138-kV Onshore (Parallel Roads)		138-kV Onshore (Parallel Railway)		69-kV Onshore (Parallel Railway)	
	132 MW Load	WNC Rating	132 MW Load	WNC Rating	132 MW Load	WNC Rating
335	0.42	0.53	0.42	0.53	0.95	1.15
336	0.42	0.53	0.42	0.53	0.95	1.15
337	0.42	0.53	0.42	0.53	0.95	1.15
338	0.42	0.53	0.42	0.53	0.95	1.15
339	0.42	0.53	0.42	0.53	0.95	1.15
340	0.42	0.53	0.42	0.53	0.95	1.15
341	0.42	0.53	0.42	0.53	0.95	1.15
342	0.42	0.53	0.42	0.53	0.95	1.15
343	0.42	0.53	0.42	0.53	0.95	1.15
344	0.42	0.53	0.42	0.53	0.95	1.15
345	0.42	0.53	0.42	0.53	0.95	1.15
346	0.42	0.53	0.42	0.53	0.95	1.15
347	0.42	0.53	0.42	0.53	0.95	1.15
348	0.42	0.53	0.42	0.53	0.95	1.15
349	0.42	0.53	0.42	0.53	0.95	1.15
350	0.42	0.53	0.42	0.53	0.95	1.15
351	0.42	0.53	0.42	0.53	0.95	1.15
352	0.42	0.53	0.42	0.53	0.95	1.15
353	0.42	0.53	0.42	0.53	0.95	1.15
354	0.42	0.53	0.42	0.53	0.95	1.15
355	0.42	0.53	0.42	0.53	0.95	1.15
356	0.42	0.53	0.42	0.53	0.95	1.15
357	0.42	0.53	0.42	0.53	0.95	1.15
358	0.42	0.53	0.42	0.53	0.95	1.15
359	0.42	0.53	0.42	0.53	0.95	1.15
360	0.42	0.53	0.42	0.53	0.95	1.15
361	0.42	0.53	0.42	0.53	0.95	1.15
362	0.42	0.53	0.42	0.53	0.95	1.15
363	0.42	0.53	0.42	0.53	0.95	1.15
364	0.42	0.53	0.42	0.53	0.95	1.15
365	0.42	0.53	0.42	0.53	0.95	1.15
366	0.42	0.53	0.42	0.53	0.95	1.15
367	0.42	0.53	0.42	0.53	0.95	1.15
368	0.42	0.53	0.42	0.53	0.95	1.15
369	0.42	0.53	0.42	0.53	0.95	1.15
370	0.42	0.53	0.42	0.53	0.95	1.15
371	0.42	0.53	0.42	0.53	0.95	1.15
372	0.42	0.53	0.42	0.53	0.95	1.15

Dist (ft) from duct bank centerline	138-kV Onshore (Parallel Roads)		138-kV Onshore (Parallel Railway)		69-kV Onshore (Parallel Railway)	
	132 MW Load	WNC Rating	132 MW Load	WNC Rating	132 MW Load	WNC Rating
373	0.42	0.53	0.42	0.53	0.95	1.15
374	0.42	0.53	0.42	0.53	0.95	1.15
375	0.42	0.53	0.42	0.53	0.95	1.15
376	0.42	0.53	0.42	0.53	0.95	1.15
377	0.42	0.53	0.42	0.53	0.95	1.15
378	0.42	0.53	0.42	0.53	0.95	1.15
379	0.42	0.53	0.42	0.53	0.95	1.15
380	0.42	0.53	0.42	0.53	0.95	1.15
381	0.42	0.53	0.42	0.53	0.95	1.15
382	0.42	0.53	0.42	0.53	0.95	1.15
383	0.42	0.53	0.42	0.53	0.95	1.15
384	0.42	0.53	0.42	0.53	0.95	1.15
385	0.42	0.53	0.42	0.53	0.95	1.15
386	0.42	0.53	0.42	0.53	0.95	1.15
387	0.42	0.53	0.42	0.53	0.95	1.15
388	0.42	0.53	0.42	0.53	0.95	1.15
389	0.42	0.53	0.42	0.53	0.95	1.15
390	0.42	0.53	0.42	0.53	0.95	1.15
391	0.42	0.53	0.42	0.53	0.95	1.15
392	0.42	0.53	0.42	0.53	0.95	1.15
393	0.42	0.53	0.42	0.53	0.95	1.15
394	0.42	0.53	0.42	0.53	0.95	1.15
395	0.42	0.53	0.42	0.53	0.95	1.15
396	0.42	0.53	0.42	0.53	0.95	1.15
397	0.42	0.53	0.42	0.53	0.95	1.15
398	0.42	0.53	0.42	0.53	0.95	1.15
399	0.42	0.53	0.42	0.53	0.95	1.15
400	0.42	0.53	0.42	0.53	0.95	1.15
401	0.42	0.53	0.42	0.53	0.95	1.15
402	0.42	0.53	0.42	0.53	0.95	1.15
403	0.42	0.53	0.42	0.53	0.95	1.15
404	0.42	0.53	0.42	0.53	0.95	1.15
405	0.42	0.53	0.42	0.53	0.95	1.15
406	0.42	0.53	0.42	0.53	0.95	1.15
407	0.42	0.53	0.42	0.53	0.95	1.15
408	0.42	0.53	0.42	0.53	0.95	1.15
409	0.42	0.53	0.42	0.53	0.95	1.15
410	0.42	0.53	0.42	0.53	0.95	1.15

Dist (ft) from duct bank centerline	138-kV Onshore (Parallel Roads)		138-kV Onshore (Parallel Railway)		69-kV Onshore (Parallel Railway)	
	132 MW Load	WNC Rating	132 MW Load	WNC Rating	132 MW Load	WNC Rating
411	0.42	0.53	0.42	0.53	0.95	1.15
412	0.42	0.53	0.42	0.53	0.95	1.15
413	0.42	0.53	0.42	0.53	0.95	1.15
414	0.42	0.53	0.42	0.53	0.95	1.15
415	0.42	0.53	0.42	0.53	0.95	1.15
416	0.42	0.53	0.42	0.53	0.95	1.15
417	0.42	0.53	0.42	0.53	0.95	1.15
418	0.42	0.53	0.42	0.53	0.95	1.15
419	0.42	0.53	0.42	0.53	0.95	1.15
420	0.42	0.53	0.42	0.53	0.95	1.15
421	0.42	0.53	0.42	0.53	0.95	1.15
422	0.42	0.53	0.42	0.53	0.95	1.15
423	0.42	0.53	0.42	0.53	0.95	1.15
424	0.42	0.53	0.42	0.53	0.95	1.15
425	0.42	0.53	0.42	0.53	0.95	1.15
426	0.42	0.53	0.42	0.53	0.95	1.15
427	0.42	0.53	0.42	0.53	0.95	1.15
428	0.42	0.53	0.42	0.53	0.95	1.15
429	0.42	0.53	0.42	0.53	0.95	1.15
430	0.42	0.53	0.42	0.53	0.95	1.15
431	0.42	0.53	0.42	0.53	0.95	1.15
432	0.42	0.53	0.42	0.53	0.95	1.15
433	0.42	0.53	0.42	0.53	0.95	1.15
434	0.42	0.53	0.42	0.53	0.95	1.15
435	0.42	0.53	0.42	0.53	0.95	1.15
436	0.42	0.53	0.42	0.53	0.95	1.15
437	0.42	0.53	0.42	0.53	0.95	1.15
438	0.42	0.53	0.42	0.53	0.95	1.15
439	0.42	0.53	0.42	0.53	0.95	1.15
440	0.42	0.53	0.42	0.53	0.95	1.15
441	0.42	0.53	0.42	0.53	0.95	1.15
442	0.42	0.53	0.42	0.53	0.95	1.15
443	0.42	0.53	0.42	0.53	0.95	1.15
444	0.42	0.53	0.42	0.53	0.95	1.15
445	0.42	0.53	0.42	0.53	0.95	1.15
446	0.42	0.53	0.42	0.53	0.95	1.15
447	0.42	0.53	0.42	0.53	0.95	1.15
448	0.42	0.53	0.42	0.53	0.95	1.15

Dist (ft) from duct bank centerline	138-kV Onshore (Parallel Roads)		138-kV Onshore (Parallel Railway)		69-kV Onshore (Parallel Railway)	
	132 MW Load	WNC Rating	132 MW Load	WNC Rating	132 MW Load	WNC Rating
449	0.42	0.53	0.42	0.53	0.95	1.15
450	0.42	0.53	0.42	0.53	0.95	1.15
451	0.42	0.53	0.42	0.53	0.95	1.15
452	0.42	0.53	0.42	0.53	0.95	1.15
453	0.42	0.53	0.42	0.53	0.95	1.15
454	0.42	0.53	0.42	0.53	0.95	1.15
455	0.42	0.53	0.42	0.53	0.95	1.15
456	0.42	0.53	0.42	0.53	0.95	1.15
457	0.42	0.53	0.42	0.53	0.95	1.15
458	0.42	0.53	0.42	0.53	0.95	1.15
459	0.42	0.53	0.42	0.53	0.95	1.15
460	0.42	0.53	0.42	0.53	0.95	1.15
461	0.42	0.53	0.42	0.53	0.95	1.15
462	0.42	0.53	0.42	0.53	0.95	1.15
463	0.42	0.53	0.42	0.53	0.95	1.15
464	0.42	0.53	0.42	0.53	0.95	1.15
465	0.42	0.53	0.42	0.53	0.95	1.15
466	0.42	0.53	0.42	0.53	0.95	1.15
467	0.42	0.53	0.42	0.53	0.95	1.15
468	0.42	0.53	0.42	0.53	0.95	1.15
469	0.42	0.53	0.42	0.53	0.95	1.15
470	0.42	0.53	0.42	0.53	0.95	1.15
471	0.42	0.53	0.42	0.53	0.95	1.15
472	0.42	0.53	0.42	0.53	0.95	1.15
473	0.42	0.53	0.42	0.53	0.95	1.15
474	0.42	0.53	0.42	0.53	0.95	1.15
475	0.42	0.53	0.42	0.53	0.95	1.15
476	0.42	0.53	0.42	0.53	0.95	1.15
477	0.42	0.53	0.42	0.53	0.95	1.15
478	0.42	0.53	0.42	0.53	0.95	1.15
479	0.42	0.53	0.42	0.53	0.95	1.15
480	0.42	0.53	0.42	0.53	0.95	1.15
481	0.42	0.53	0.42	0.53	0.95	1.15
482	0.42	0.53	0.42	0.53	0.95	1.15
483	0.42	0.53	0.42	0.53	0.95	1.15
484	0.42	0.53	0.42	0.53	0.95	1.15
485	0.42	0.53	0.42	0.53	0.95	1.15
486	0.42	0.53	0.42	0.53	0.95	1.15

Dist (ft) from duct bank centerline	138-kV Onshore (Parallel Roads)		138-kV Onshore (Parallel Railway)		69-kV Onshore (Parallel Railway)	
	132 MW Load	WNC Rating	132 MW Load	WNC Rating	132 MW Load	WNC Rating
487	0.42	0.53	0.42	0.53	0.95	1.15
488	0.42	0.53	0.42	0.53	0.95	1.15
489	0.42	0.53	0.42	0.53	0.95	1.15
490	0.42	0.53	0.42	0.53	0.95	1.15
491	0.42	0.53	0.42	0.53	0.95	1.15
492	0.42	0.53	0.42	0.53	0.95	1.15
493	0.42	0.53	0.42	0.53	0.95	1.15
494	0.42	0.53	0.42	0.53	0.95	1.15
495	0.42	0.53	0.42	0.53	0.95	1.15
496	0.42	0.53	0.42	0.53	0.95	1.15
497	0.42	0.53	0.42	0.53	0.95	1.15
498	0.42	0.53	0.42	0.53	0.95	1.15
499	0.42	0.53	0.42	0.53	0.95	1.15
500	0.42	0.53	0.42	0.53	0.95	1.15