

Development of Noise Mitigation Measures in Offshore Wind Farm Construction 2013



Dipl. Biol. Sven Koschinski

Dipl. Biol. Karin Lüdemann

Commissioned by the
Federal Agency for Nature Conservation
(Bundesamt für Naturschutz, BfN)

Original Report (in German): published July 2011, update February 2013

Authors:

Sven Koschinski, biologist

Marine Zoology
Kühlandweg 12
24326 Nehnten, Germany
sk@meereszoologie.de



Karin Lüdemann, biologist

Wissenschaftsbuero Hamburg
Telemannstr. 56a
20255 Hamburg, Germany
info@wissensbuero-hh.de



Supervision (BfN): Thomas Merck

Cover photos:

- Upper left: Hydro Sound Dampers (photo: PATRICE KUNTE, source: ELMER et al. 2012)
- Upper right: Big bubble curtain in the OWF *Borkum West II* (photo: *Trianel GmbH/LANG*)
- Lower left: Little confined bubble curtain by *Weyres Offshore* (photo: PATRICE KUNTE, source: WILKE et al. 2012)
- Lower middle: Cofferdam (source: THOMSEN 2012)
- Lower right: *IHC Noise Mitigation System 6900* at the OWF *Riffgat* (source: www.riffgat.de)

This report has been funded by the Federal Agency for Nature Conservation in the frame of the project „*Erstellung einer Studie zum Stand der Entwicklung schallminimierender Maßnahmen beim Bau von Offshore-Windenergieanlagen*“

Responsibility for the content lies with the authors. The views expressed in this report are those of the authors and do not necessarily reflect those of the publisher.

All rights are reserved by the owner and publisher. In particular, this report may be cited, duplicated or made available, in whole or in part, to third parties only with the permission of the publisher.

Nehnten and Hamburg, Germany, 6 February 2013

Table of Contents

Table of Contents	I
List of Abbreviations	
1 Summary	1
2 Introduction	6
3 Development Status Categories	8
3.1 Concept Stage.....	8
3.2 Experimental Stage.....	8
3.3 Pilot Stage.....	8
3.4 Proven Technology	8
3.5 Market Availability	9
4 Noise Mitigation Measures for Impact Pile Driving	10
4.1 Preliminary Note on the Report’s Topic and Structure.....	11
4.2 Bubble Curtains	13
4.2.1 Big Bubble Curtain	14
4.2.2 Little Bubble Curtain: Several Variations.....	17
4.2.3 Valuation of Bubble Curtains.....	22
4.3 Isolation Casings	26
4.3.1 IHC Noise Mitigation System	27
4.3.2 BEKA Shells	29
4.3.3 Experience with Isolation Casings	29
4.3.4 Valuation of Isolation casings.....	33
4.4 Cofferdams	35
4.4.1 Cofferdam.....	35
4.4.2 Pile-in-Pipe Piling.....	36
4.4.3 Experience with Cofferdams	37
4.4.4 Valuation of Cofferdams	38
4.5 <i>Hydro Sound Dampers (HSD) / “Encapsulated Bubbles”</i>	40
4.5.1 Experience with <i>Hydro Sound Dampers / “Encapsulated Bubbles”</i>	41
4.5.2 Valuation of <i>Hydro Sound Dampers/“Encapsulated Bubbles”</i>	44
4.6 Acoustic Improvement of the Piling Process.....	46
4.6.1 Experience with Acoustic Improvements of the Piling Process	47
4.6.2 Valuation of Acoustic Improvements of the Piling Process.....	48
5 Low-Noise Foundations	52
5.1 Vibratory Pile Driving.....	52
5.1.1 Experience with Vibratory Piling	52
5.1.2 Valuation of Vibratory Piling	55
5.2 Drilled Foundations	56
5.2.1 Ballast Nedam.....	57
5.2.2 Offshore Foundation Drilling (OFD) (Herrenknecht/Hochtief).....	58
5.2.3 Fugro Seacore	59
5.2.4 Valuation of Drilled Foundations.....	61
5.3 Gravity Base Foundations.....	65
5.3.1 Experience with Gravity Base Foundations	65
5.3.2 Valuation of Gravity Base Foundations	69
5.4 Floating Wind Turbines	70
5.4.1 Valuation of Floating Wind Turbines.....	76

5.5	Bucket Foundations (suction bucket / suction caisson)	79
5.5.1	Experience with Bucket Foundations	80
5.5.2	Valuation of Bucket Foundations	83
6	Current German Research Projects	86
7	Future Needs for Research	88
8	Conclusions and Perspectives	89
9	References	91

List of Abbreviations

BAT	Best Available Techniques	kJ	Kilojoule
BBC	Big Bubble Curtain	km	Kilometre
BEP	Best Environmental Practice	kW	Kilowatt
BfN	<i>Bundesamt für Naturschutz</i> – Federal Agency for Nature Conservation	LBC	Layered bubble curtain, little bubble curtain
BMU	<i>Bundesministerium für Umwelt, Naturschutz und Reaktorsicherheit</i> – Federal Ministry for the Environment, Nature Conservation and Nuclear Safety	Leq	Equivalent sound pressure level
BNatSchG	<i>Bundesnaturschutzgesetz</i> , Federal Nature Conservation Act	m	metre
BORA	“Predicting underwater noise due to offshore pile driving” (German acronym)	max.	maximal
BSH	<i>Bundesamt für Seeschifffahrt und Hydrographie</i> , Federal Maritime and Hydrographic Agency	mm	millimetre
dB	decibel	MOAB	Mobile Application Platform
DIN	German Institute for Standardization	ms	milliseconds
EEH	Equal energy hypothesis	MW	megawatt
EEZ	exclusive economic zone	NMS	Noise Mitigation System
ESRa	“ <i>Evaluation of systems to mitigate pile driving noise at an offshore test pile</i> ” (German acronym)	n. s.	not specified
e.g.	exempli gratia, for example	OFD	Offshore Foundation Drilling
et al.	et alii, and others	OFT	Offshore Test (of <i>BARD</i>)
f	frequency	OWF	Offshore wind farm
FLOW	Far and Large Offshore Wind	peak	peak level (L_{peak})
GICON-SOF	Floating foundation by <i>GICON</i>	pers. comm.	personal communication
GWh	Gigawatt hour	R&D	Research and Development
HSD	Hydro Sound Dampers	rms	root mean square (corresponds to equivalent sound pressure level Leq)
Hz	Hertz	SBC	Small Bubble Curtain by <i>MENCK</i> and <i>BARD</i>
i.a.	<i>inter alia</i> , amongst others	SDP	Submerged Deepwater Platform
i.e.	<i>id est</i> , that is	SEL	Single event sound pressure level, sound exposure level
Inc.	Incorporated	SIWT	Self-installing wind turbine by <i>SPT Offshore</i>
kHz	Kilohertz	t	tonne (metric)
		TLP	Tension leg platform
		TU	Technical University
		UBA	<i>Umweltbundesamt</i> , Federal Environmental Agency
		VSM	Vertical Shaft Machine

1 Summary

The aim of this study is to describe technical noise mitigation measures to be applied during pile driving of offshore wind turbines as well as alternative low-noise foundation concepts and to analyse their applicability. A first version of this study was published in German in July 2011. In order to also cover ongoing research and further technological development, an update was requested in December 2012. On account of the importance of noise mitigation not only in a national, but also in an international context, an English version was produced in addition. However, all research was focused on German projects.

From the perspective of nature conservation, anthropogenic noise emissions into the marine environment must be limited to environmentally friendly levels. In Germany, a dual threshold value has been defined by the approving authority BSH. The observance of this threshold value of 160 dB (single event sound pressure level, SEL) / 190 dB (peak-to-peak¹) at 750 m from the source is mandatory for the installation of offshore wind turbines in the German exclusive economic zone (EEZ). For commonly used piled foundations it can only be met by applying noise mitigation measures. In Germany at least the industry has stepped up efforts to improve available noise mitigation techniques for pile driving of offshore wind turbines or to invent new systems only in the last few years.

Depending on parameters which influence the source level such as pile diameter, soil structure and blow energy, many noise mitigation systems have the potential to reduce emissions to a level that corresponds to or even falls below the noise limit mandatory in the German EEZ. However, they all have an impact on the operations layout and work schedule as the systems have to be applied prior to pile driving or require special technical features of the installation barge. Minimising the duration of the installation of the noise mitigation system is one of the major challenges when striving to achieve an application of a noise mitigation system which is economically feasible. This holds true for bubble curtains ([chapter 4.2](#)), isolation casings ([chapter 4.3](#)), and cofferdams ([chapter 4.4](#)) as well as for Hydro Sound Dampers ([chapter 4.5](#)). So far, not all of the available systems have been routinely applied, and thus the time required for the installation process cannot be predicted with certainty. Further development is aimed at the best possible integration of the installation of the mitigation system into the operations layout.

[Table 1](#) briefly summarises the noise mitigation measures examined in this study, their noise reduction potential and their respective development status.

¹ Contrary to the German DIN standard 1320, the Federal Environmental Agency uses the peak-to-peak level which exceeds the corresponding peak level by up to 6 dB

Table 1: Noise mitigation measures for impact pile driving, their reduction potential, development status und next steps (n. s. = not specified; SEL = Single event sound pressure level; peak = peak level)
Note: Noise reductions specified as broadband levels are not directly comparable to those specified as mitigation levels in singular third octave bands!

	Mitigation measure	Noise reduction	Development status ¹⁾	Questions, next steps
Bubble curtains	Big bubble curtain	<ul style="list-style-type: none"> • FINO 3: 12 dB (SEL), 14 dB (peak) (GRIEBMANN et al. 2010), OWF <i>Borkum West II</i>: 11-15 dB (SEL), 8-13 dB (peak) (BELLMANN 2012) • Double big bubble curtain (two half-circles): 17 dB (SEL), 21 dB (peak) (HEPPER 2012) 	<ul style="list-style-type: none"> • Proven technology, potential for optimisation • German 160 dB threshold level can be met under certain environmental conditions 	<ul style="list-style-type: none"> • Practical application in several commercial offshore wind farms (OWFs) • Application with larger pile diameters at larger water depth • Potential for optimization with respect to effectiveness and handling
	Little bubble curtain (several variations)	<ul style="list-style-type: none"> • Layered ring system (OWF <i>alpha ventus</i>): 12 dB (SEL), 14 dB (peak) (GRIEBMANN 2009); OWF <i>Baltic II</i>: 15 dB (SEL) (SCHULTZ-VON GLAHN 2011) resp. 11-13 dB (SEL) (ZERBST & RUSTEMEIER 2011) 	<ul style="list-style-type: none"> • Pilot stage with full-scale test completed 	<ul style="list-style-type: none"> • Practical application, currently no specific projects known
		<ul style="list-style-type: none"> • Confined little bubble curtain (ESRa): 4-5 dB (SEL) (WILKE et al. 2012)²⁾ • Little bubble curtain with vertical hoses (SBC): 14 dB (SEL), 20 dB (peak) (STEINHAGEN 2012) 		
Isolation casings	<i>IHC Noise Mitigation System</i>	<ul style="list-style-type: none"> • ESRa project: 5-8 dB (SEL) (WILKE et al. 2012)²⁾ • FLOW-project: OWF <i>Nordsee Ost</i>: 9 dB (SEL), Ijmuiden: 11 dB (SEL) • OWF <i>Riffgat</i>: 17 dB (SEL) (GERKE & BELLMANN 2012)³⁾ 	<ul style="list-style-type: none"> • Pilot stage completed • First application at commercial OWF <i>Riffgat</i> • 160 dB threshold level can be met with small and intermediate piles at shallow depths 	<ul style="list-style-type: none"> • During further applications a direct comparison with and without mitigation system is required • Application at greater water depths and with larger diameters
	<i>BEKA-Shells</i>	<ul style="list-style-type: none"> • ESRa project: 6-8 dB (SEL) (Wilke et al. 2012)²⁾ 	<ul style="list-style-type: none"> • Pilot stage completed 	<ul style="list-style-type: none"> • Full-scale test under offshore conditions • Currently no commercial application known
Cofferdam	Cofferdam	<ul style="list-style-type: none"> • Aarhus Bight: 23 dB (SEL), 17 dB (peak) (THOMSEN 2012) 	<ul style="list-style-type: none"> • Pilot stage for free-standing system completed • First application in commercial projects planned 	<ul style="list-style-type: none"> • Full-scale test for larger monopiles (Ø about 5 m) • Practical application in commercial projects <i>HelWin alpha</i>, <i>BorWin beta</i> and <i>Sylwin alpha</i> planned • Further development of telescopic system
	Pile-in-Pipe Piling	<ul style="list-style-type: none"> • Model: 27 dB (SEL) (FRÜHLING et al. 2011) 	<ul style="list-style-type: none"> • Validated concept stage 	<ul style="list-style-type: none"> • n. s.

	Mitigation measure	Noise reduction	Development status ¹⁾	Questions, next steps
Others	Hydro Sound Dampers (HSD)/ "encapsulated bubbles"	<ul style="list-style-type: none"> • <i>ESRa</i> project: 4-14 dB (SEL) (WILKE et al. 2012)²⁾ • OWF <i>London Array</i>: n. s. • Feasibility study US: in singular third octave bands up to 18 dB (no broadband value given) (LEE et al. 2012) 	<ul style="list-style-type: none"> • Pilot stage, application in commercial OWF <i>London Array</i> 	<ul style="list-style-type: none"> • Further offshore test (OWF <i>Dan Tysk</i>) planned for 2013 • Optimisation of <i>HSD</i> elements • Additional <i>HSD</i> elements and net-layers • Tests to reduce seismic influence
	Prolongation of pulse duration	<ul style="list-style-type: none"> • Model: 4 dB (SEL), 9 dB (peak) (ELMER et al. 2007a) • Schall 3: Model of <i>MENCK</i> test pile: 5 dB (SEL), 7 dB (peak). Model of <i>FINO 3</i> pile: 11 dB (SEL), 13 dB (peak) (NEUBER & UHL 2012) • Measurement of coiled steel cable as piling cushion: up to 7 dB (SEL) 4) (ELMER et al. 2007a) • Measurement of piling cushions from Micarta: 7-8 dB, Nylon 4-5 dB 5) (LAUGHLIN 2006) 	<ul style="list-style-type: none"> • 160 dB threshold level can be met with very small pile diameters, used as a means of protecting the equipment • Experimental stage for larger piles (numerical models and simulation) 	<ul style="list-style-type: none"> • n. s.
	Modification of piling hammer	<ul style="list-style-type: none"> • n. s. 	<ul style="list-style-type: none"> • Experimental stage 	<ul style="list-style-type: none"> • Completion of research project <i>BORA</i> and publication of results

¹⁾ With regard to North Sea offshore conditions and water depths of about 40 m

²⁾ For the interpretation of the results achieved in the *ESRa* project, the problems outlined in [chapter 4.1](#) have to be taken into consideration

³⁾ Calculation of noise reduction is based only on the predicted value of noise emission without mitigation system, see [chapter 4.3.4](#)

⁴⁾ *FINO 2* platform (pile diameter 3.3 m)

⁵⁾ Cape Disappointment (pile diameter 0.3 m)

In addition, several alternative foundation types exist or are under development. With these, wind turbines can be founded without impact pile driving and therefore less underwater noise generation is expected. Such low-noise foundations are vibratory pile driving ([chapter 5.1](#)), foundation drilling ([chapter 5.2](#)), gravity base foundations ([chapter 5.3](#)), floating wind turbines ([chapter 5.4](#)) and bucket foundations ([chapter 5.5](#)) ([Table 1](#)). For most of these technologies, noise measurements during the offshore installation process are not yet available. Based on estimations by expert opinion or on data given by construction companies it can be expected that the noise emissions are below the threshold of 160/190 dB. During the installation, continuous rather than impulsive sound is emitted. However, the impact of continuous sound of a given level cannot be directly compared to the impact of impulsive sound of the same level. Finally, information on current research projects ([chapter 6](#)) and future needs for research ([chapter 7](#)) are compiled.

Table 2: Low-noise foundations, their reduction potential, development status und next steps (n. s. = not specified; Leq = equivalent continuous sound level)

	Method / project	Noise emission during construction	Development status ¹⁾	Questions, next steps
Vibratory pile driving	Vibratory pile driving	<ul style="list-style-type: none"> • Sound level reduced by about 15-20 dB compared to impact pile driving (ELMER et al. 2007a) • North Sea, OWF <i>alpha ventus</i>: broadband sound level 142 dB at 750 m from source; but high tonal component (BETKE & MATUSCHEK 2010), OWF <i>Riffgat</i>: 145 dB Leq (GERKE & BELLMANN 2012) • Number of pile strikes reduced 	<ul style="list-style-type: none"> • Proven technology for small piles and low anchoring depths and prior to the actual impact pile driving (OWF <i>Riffgat</i>) 	<ul style="list-style-type: none"> • `Vibratory pile driving applicable to entire anchoring depths? • Is the same stability under load achievable?
Foundation drilling	<i>Ballast Nedam</i>	<ul style="list-style-type: none"> • n. s. 	<ul style="list-style-type: none"> • Concept stage • Technical feasibility proven (VAN DE BRUG 2011) 	<ul style="list-style-type: none"> • Pilot stage planned at <i>FLOW</i> project
	<i>Herrenknecht</i>	<ul style="list-style-type: none"> • Measurement at watered shaft in Naples: 117 dB (SEL) at 750 m (AHRENS & WIEGAND 2009) 	<ul style="list-style-type: none"> • Technical feasibility proven (AHRENS & WIEGAND 2009) • Onshore tests • Prototype under construction 	<ul style="list-style-type: none"> • Investigations of carrying capacity • Construction of prototype for 2013 • Nearshore test 4th quarter 2013 • Offshore prototype-test beginning of 2014
	<i>Fugro Seacore</i>	<ul style="list-style-type: none"> • n. s. 	<ul style="list-style-type: none"> • Proven technology for certain types of ground (rock, sand- and limestone) and in combination with impulsive pile driving 	<ul style="list-style-type: none"> • Investigations of resulting stability under load when founded without impulsive piling • Applicability to sandy sediments?
Gravity base foundations	Gravity base foundations	<ul style="list-style-type: none"> • No specific measurements available • Noise emissions during ground preparation works (if required) probably lower than during impulsive pile driving 	<ul style="list-style-type: none"> • For offshore wind turbines: proven technology at water depths ≤ 20 m, pilot stage for deeper water • Onshore full scale test foundation • For oil & gas: proven technology also at greater water depths 	<ul style="list-style-type: none"> • Question of detail on scour protection
Floating wind turbines	Floating wind turbines in general	<ul style="list-style-type: none"> • No specific measurements available • Noise emissions probably lower than during impulsive pile driving 	<ul style="list-style-type: none"> • Oil and gas platforms: proven technology • Offshore wind turbines: experimental or pilot stage 	<ul style="list-style-type: none"> • Details of anchorage • Operational noise of wind turbines possibly louder than with other foundation types
	<i>HYWIND</i>	<ul style="list-style-type: none"> • n. s. 	<ul style="list-style-type: none"> • Pilot stage, Full-Scale-test in Norway, two year research project completed 	<ul style="list-style-type: none"> • n. s.

Floating wind turbines	<i>Blue H</i>	• n. s.	<ul style="list-style-type: none"> • Pilot stage • Experimental stage with 75% model completed 	• Subproject continued in a different form by <i>Blue H Engineering</i> (see below)
	<i>Blue H Engineering</i>	• n. s.	• Conceptual stage for 5 MW turbines	• Prototype planned for 2016
	<i>GICON-SOF</i>	• n. s.	<ul style="list-style-type: none"> • Experimental stage • Development of planning tool for technical, ecological and economic design-basis for prospected research facility • Investigations in wave channel completed 	• Prototype planned for 2012
	<i>WindFloat</i>	• n. s.	• 2011: Prototype erected in Portugal with Vestas V80	• 5 more turbines planned
	<i>Sway</i>	• n. s.	<ul style="list-style-type: none"> • Experimental stage completed: Dynamic simulations completed • Pilot stage: prototype approved 	• Prototype planned for 2013
	<i>WINDSEA</i>	• n. s.	• Experimental stage with 1:40 model in wind- and wave-channel completed	• Search for investors
	<i>INFLOW</i>	• n. s.	<ul style="list-style-type: none"> • Experimental stage • Onshore demonstration model at a scale of 1:2 completed (output 35 kW) 	• Prototype planned for 2013
	<i>WINFLO</i>	• n. s.	<ul style="list-style-type: none"> • Ongoing model-tests • Prototype under construction 	• Prototype planned for 2013
	Poseidon 37	• n. s.	• Prototype (37 m width) with 3x11 kW output completed	<ul style="list-style-type: none"> • Larger prototype (80 m width) planned for 2015 • Subsequent prototype of 110 m width planned for 2016/2017
Bucket foundations	Bucket foundation for transformer platform		• Oil and gas platforms: proven technology	• Construction of converter platforms at commercial OWFs <i>Veja Mate</i> and <i>Global Tech 1</i>
	Bucket foundation for offshore wind turbine	<ul style="list-style-type: none"> • n. s. • Noise emissions during suction dredging probably lower than during impulsive pile driving 	<ul style="list-style-type: none"> • Pilot stage for monopod: prototype at Frederikshavn/DK • Concept stage for Tri-jacket • Experimental stage for asymmetric three-legged construction (model tests completed) 	<ul style="list-style-type: none"> • Tri-Jacket: full-scale prototype planned at virtual test field • Asymmetric three-legged construction: full-scale prototype planned

* With regard to North Sea offshore conditions and water depths of about 40 m

2 Introduction

Impact pile driving is the prevailing installation method for offshore wind turbines. This technique is of special concern for the marine environment as it generates very high broad-band noise levels that have the potential to harm marine organisms like marine mammals or fish over considerable distances. Hence, from the perspective of nature conservation, such anthropogenic noise emissions into the marine environment have to be avoided or limited to environmentally friendly levels. Based on improved knowledge of the impacts of underwater noise on the marine ecosystem, a current focus of research and development by science, industry and public authorities is the improvement of effective noise mitigation methods. In Germany, dual threshold values have been defined for the approval process of offshore wind farms in the EEZ by the approving authority *BSH*. During pile driving, underwater noise immissions must not exceed 160 dB (single event sound pressure level, SEL) or 190 dB (peak-to-peak²) at 750 m from the source (UMWELTBUNDESAMT 2011, BSH 2012).

Measurements of impulsive noise are available from various pile driving activities (NEHLS et al. 2007). Maxima of the spectral distribution were found in the frequency range between 125 Hz and 200 Hz during construction of the research platforms *FINO 1* and *FINO 2*, the met mast *Amrumbank West* and the offshore wind farm (OWF) *alpha ventus* (BETKE & MATUSCHEK 2010). The piling strikes consist of short pulses with 50-100 ms duration each.

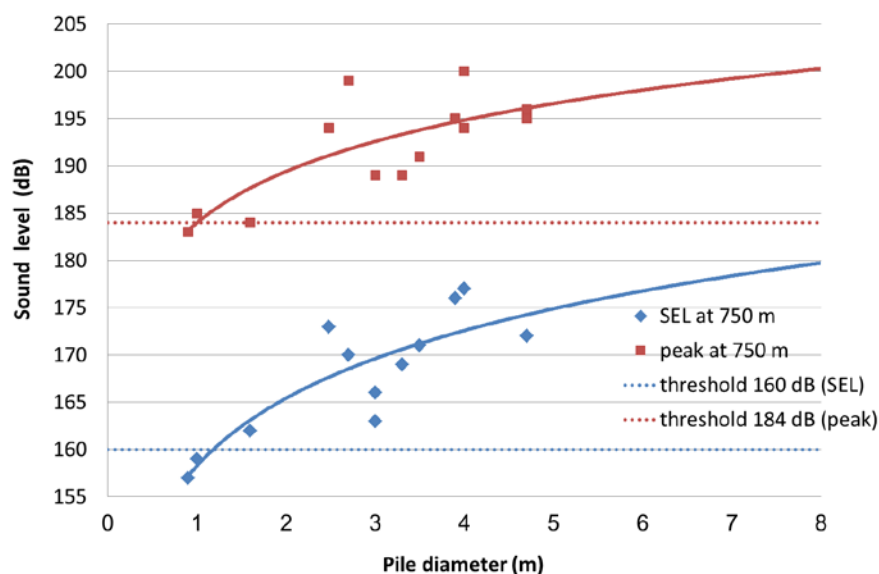

Figure 1: Noise level (SEL and peak) during offshore constructions as a function of pile diameter. The results were converted to a distance of 750 m, the relevant distance of the German 160 dB threshold level. The peak level of 184 dB corresponds to the threshold of 190 dB (peak-to-peak) (source: BETKE 2008, complemented by data of BETKE & MATUSCHEK 2010)

Results of measurements during pile driving at various offshore locations show a positive correlation between blow energy and the resulting sound pressure level and the pile diameter (BETKE 2008, BETKE & MATUSCHEK 2010). Other parameters which influence the sound pressure level are the soil structure and the size of the hydraulic hammer. Pile diameter and foundation type depend *i. a.* on the soil structure, water depth and the turbine used. [Figure 1](#) illustrates the correlation between underwater noise level (SEL and peak) and pile diameter. The logarithmic trend curve in [Figure 1](#) is based on the

² See footnote 1

results of 14 *in situ* measurements with pile diameters between 0.9 and 4.7 m (BETKE 2008, BETKE & MATUSCHEK 2010). The results of every additional noise measurement improve our understanding of the underlying principles. [Figure 1](#) gives a rough estimate of the noise reduction that has to be achieved by suitable mitigation techniques in order to meet the mandatory noise limit. For pile diameters of about 3 m, a noise reduction by 10 dB (SEL) may be sufficient to meet the 160 dB threshold level, whereas a pile diameter of 5 m requires a reduction in the range of 15 dB (SEL).

This study summarises the available information on noise mitigation techniques for impact pile driving and analyses their applicability. A general technical description of each measure is given, accompanied by information on the respective development status (concept stage, experimental stage, pilot stage, proven technology, market availability, see [chapter 3](#)). Experience gained so far and the resulting noise reduction are presented for every mitigation method.

A controversial discussion about an additional suitable threshold value aiming at avoiding disturbance of marine mammal and possible resulting impacts on population level is ongoing. Furthermore, in the light of available estimates of possible noise reduction there is reason to suspect that, despite the application of noise mitigation techniques, the aforementioned threshold cannot be met in every case. Therefore, in a second part, alternative “low-noise” foundation concepts are presented which produce less noise during installation than impact pile driving. However, it must be considered that the installation of alternative foundation types also induces noise. Based on current knowledge these noise immissions cannot be properly quantified as no offshore measurements are available to date. In some cases even certain construction details are not yet known.

The main focus of the study was on German projects. The study does not claim to provide a complete overview of all measures and providers. Impacts on the marine environment other than noise are not discussed in this study.

Nevertheless, mitigating underwater noise should also be taken into account in an international context. In order to prevent and eliminate marine pollution the application of Best Available Techniques/Technology (BAT) and Best Environmental Practice (BEP) is a requirement under both the Convention for the Protection of the Marine Environment of the North-East Atlantic (OSPAR Convention) and of the Convention on the Protection of the Marine Environment of the Baltic Sea Area (Helsinki Convention).³ Moreover, the precautionary principle has to be applied under both conventions.⁴ Although the concept of BAT and BEP was initially created for land-based and diffuse pollution OSPAR has adopted a large number of recommendations and decisions on BAT and BEP for various industrial technologies. Since noise is internationally recognized as pollution⁵, the concept of BAT and BEP should also be applied to offshore construction activities. BAT and BEP for particular sources will change with progress in technology and scientific knowledge.

³ See Art. 2 (3) (b), Appendix 1 OSPAR Convention; Art. 3 (3), Annex II Helsinki Convention.

⁴ Art. 2 (2) OSPAR Convention, Art. 3 (2) Helsinki Convention.

⁵ “Pollution” means the introduction by man, directly or indirectly, of substances or energy into the maritime area which results, or is likely to result, in hazards to human health, harm to living resources and marine ecosystems, damage to amenities or interference with other legitimate uses of the sea. (as defined by Article 1 (d) of the OSPAR Convention).

3 Development Status Categories

This section provides definitions of various categories of the development status from the idea to the achievement of market availability. This study presents a purely technical description and assessment of the development status of various mitigation measures, alternative foundations and their mitigation potential.

3.1 Concept Stage

A project idea together with extensive compilations of information, physical calculations and rationales for elaborate plans is available. Predictions of the object's or method's effectiveness are primarily based on theoretical considerations and conclusions by analogy. A validated conception comprises additional preliminary tests and investigations of the feasibility, e.g. load tests, aided by models. A prototype of the development object does not yet exist.

3.2 Experimental Stage

The next developmental stage is reached when tests of the technique in the laboratory or in a comparable test facility (e.g. wave channel) are conducted. The aim of the trials is the development of a prototype. Some developments are based on components that are market available but have to be modified for a new field of application.

3.3 Pilot Stage

In a first application the tested technique is applied in a close-to-reality situation. Development has progressed beyond the experimental stage. The object may however be an individual item, e.g. a prototype not yet produced in serial production. The aim of the application is to prove the technical and - more importantly - the economic suitability. In most cases the application is completed by a scientific-technical evaluation of a full-scale test or a pilot or demonstration project. This is often required as a prerequisite for obtaining financing by a bank.

3.4 Proven Technology

A noise mitigation method must be regarded as "proven technology" if it has repeatedly been applied during the construction of a commercial OWF, and has thereby shown its practicability. This includes the verification of a significant reduction of noise emissions which can be achieved and reproduced with sufficient certainty. The noise reduction does not necessarily need to ensure meeting a given threshold level (e.g. 160 dB SEL) under all imaginable circumstances and environmental conditions i.e. with respect to diameter, blow energy, water depth, sediment types, etc.

During a commercial offshore application it is still possible that a certain mitigation technology does not achieve the same noise reduction at all foundations. This phase can still be characterised by a number of imponderables. Thus, further optimisation may be necessary and further adjustments of the noise mitigation system may be needed even during on-going construction works.

Operating Conditions

Within the scope of this study, proven technology relates to offshore conditions in the German EEZ of the North Sea and the Baltic Sea with their prevailing environmental conditions. This relates to the prevailing current flow, water depths of about 40 m and mostly sandy substrates in the North Sea, whereas in the Baltic Sea chalky layers or muddy layers also typically occur.

Specifically with regard to alternative low-noise foundation concepts ([chapter 5](#)), the technical aim of a technology may be important. For example, components of the foundations may be proven technology in the oil- and gas industry, but when applied to offshore wind turbines they are subject to different loads and must be modified accordingly.

3.5 Market Availability

Market availability implies that a technique has proven its effectiveness and it is available at economic conditions. Often there are several competing providers offering variations of one technology. Usually a market-available technology is a prerequisite for an adequate price calculation. During the experimental stage and also during the first applications there remain imponderables that have an impact on the costs.

4 Noise Mitigation Measures for Impact Pile Driving

Based on practical examples, models and concepts, this chapter presents advanced noise mitigation techniques for pile driving noise. Due to the development of increasingly large monopiles and the construction of wind farms at ever-increasing distances from the shore, the diameter of piles for the foundation of offshore turbines will be an important factor for noise mitigation at the source. The offshore industry is capable of providing hydraulic hammers sufficient to embed such large monopiles in dense glacial deposits of sands. The utilisation of larger piles leads to an increase of the soil resistance which requires more impact energy which again leads to higher sound levels in the process of pile driving (Figure 1). Therefore, larger pile diameters require more effective noise mitigation techniques in order to meet the 160 dB threshold level at 750 m.

In the future, a higher noise reduction might be achieved by further optimisation of the available noise mitigation measures. But the potential for technical noise mitigation is limited by several factors such as multipath transmission of sound waves. The airborne path may not contribute much to underwater sound since much of it is reflected at the surface. The structure-borne radiation path from the submerged part of the pile into the water column can be attenuated by existing noise mitigation methods, whereas damping of the seismic path from the embedded section of the pile into the sediments is difficult. A considerable amount of sound energy may re-enter the water column via the seismic path (as depicted in Figure 2). The seismic contribution to the overall sound transmission in water is 10-30 dB below the combination of all three paths (APPLIED PHYSICAL SCIENCES 2010). Hence even with a considerable optimisation of current noise mitigation techniques, the maximum achievable noise reduction will remain limited to about 30 dB as long as the seismic path is not attenuated as well.

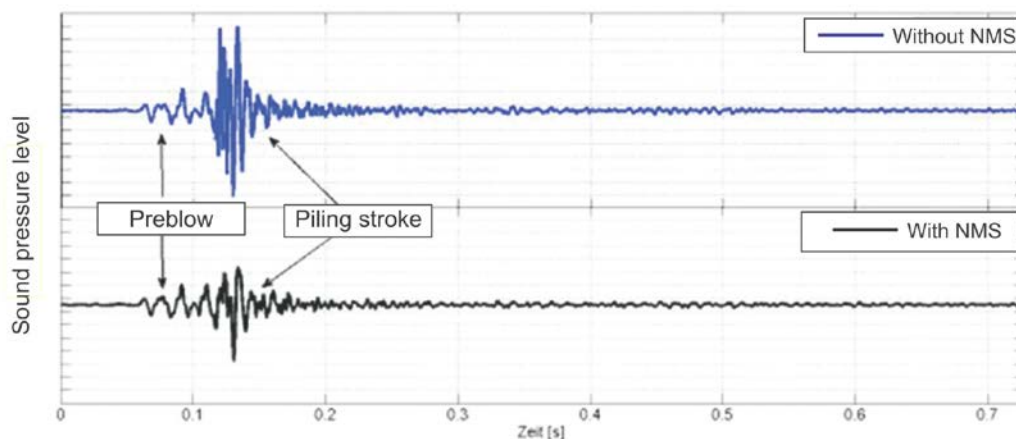

Figure 2: "Preblow" within the time signal of the underwater sound, directly followed by the pile blow (distance: 750 m, blow energy 300 kJ) without (above) and with (below) noise mitigation system. The preblow is the signal of the seismic sound impulse coupled to the water column which spreads faster in the ground than the generic underwater sound signal. It is evident from the high amplitude of the preblow that only water-radiated sound is mitigated (source: WILKE et al. 2012, modified)

The key to effectively reducing underwater noise with respect to the broadband sound pressure level is a mitigation in the low frequency range of about 100-400 Hz (in a near field ⁶situation up to 800 Hz, see WILKE et al. 2012), as major energy is emitted in this frequency range (Figure 3). In order to avoid significant disturbance of a certain species e.g. in a critical habitat, a different part of the spectrum may be of interest. In this case, hearing abilities must be taken into account rather than maximum attenuation which is important for avoiding hearing damage.

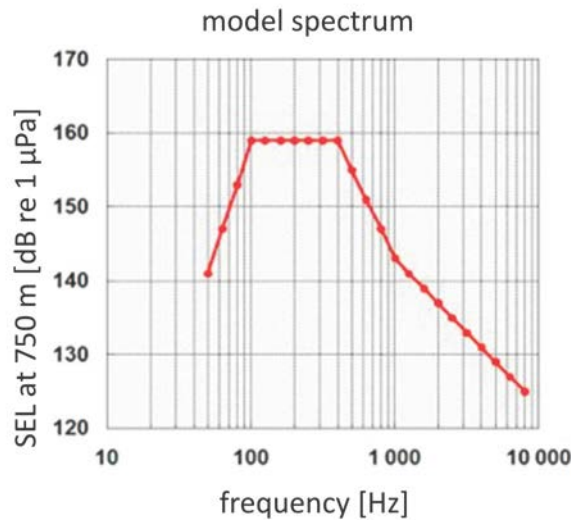

Figure 3: Model sound spectrum for a single blow in the far field, based on several *in situ* measurements of pile driving noise (source: *itap GmbH* in WILKE et al. 2012, modified)

4.1 Preliminary Note on the Report`s Topic and Structure

Initial results of investigations on pile driving noise mitigation using a bubble curtain during the construction of an aviation fuel receiving facility close to the international airport of Hong Kong in 1996 were promising (WÜRSIG et al. 2000). Following this study, there was a multitude of research projects in Germany on the mitigation of pile driving noise. These studies are a fundamental basis of this chapter including:

- Sound measurements during tests of several noise mitigation methods at a test pile in Lübeck Bight in 2005 and 2011 in the context of the *Environmental Research Plan* by the Federal Ministry for the Environment, Nature Conservation and Nuclear Safety, and *ESRa* (Evaluation of systems to mitigate pile driving noise) (SCHULTZ-VON GLAHN et al. 2006, WILKE et al. 2012)
- Investigations into prolonging the duration of piling blows by modifications of the piling hammer and anvil at the research platform *FINO 2* (ELMER et al. 2007b)
- Noise measurements during trials with the big bubble curtain in the course of the construction of the research platform *FINO 3* (GRIEBMANN et al. 2009)

⁶ The acoustic near field is frequency dependent and extends in airborne noise to twice the wave length. WILKE et al. (2012) assume that the near field of underwater noise extends to between twice and ten times the wave length. Many acoustic principles and calculation methods are only valid in the far field.

- Proof of concept, test, realisation and validation of low-noise construction techniques and noise mitigation measures during the construction of offshore wind turbines *Schall 3* (RUSTEMEIER et al. 2012)
- Research during tests of a layered bubble curtain at the offshore test site *alpha ventus* in the North Sea (BETKE & MATUSCHEK 2010).
- Sound measurements during construction of the first commercial offshore wind farms in German waters when noise mitigation measures were applied
- Investigation of the effectiveness of *Hydro Sound Dampers* by *OffNoise Solutions GmbH* and the *Technical University of Braunschweig* (ELMER 2010, ELMER et al. 2011, 2012) and studies at the *University of Texas, Austin*, on sound mitigation properties of encapsulated gas bubbles in water (LEE et al. 2010, 2011, 2012)

The research projects include modelling of effects as well as small-scale laboratory tests and initial offshore applications. It can be shown that it is not generally feasible to transfer results obtained during preliminary experiments at a small-scale to a typical offshore situation. Moreover, specific attenuation values cannot be guaranteed. Results strongly depend on soil conditions and the characteristics of the pile. Factors of uncertainty of the noise reduction performance may be technical details, or details in the construction process.

Problems due to unfavourable weather conditions occurred e.g. during the construction process of the OWF *alpha ventus* in the German North Sea. The layered bubble curtain was not fully deployed. Only a pre-installed lower part of the bubble curtain could be activated. An additional mobile upper system could not be installed (BETKE & MATUSCHEK 2010). Subsequent observations revealed that the tidal current caused the bubbles to drift away, resulting in large unwanted acoustic bridges which greatly reduced the effectiveness of the system. Therefore, the bubble curtain was only effective in the direction of the tidal current where the bubbles actually shielded the pile from the surrounding water.

During the *ESRa* project, a layered bubble curtain ([chapter 4.2.2.1](#)), three different types of isolation casings (IHC Noise Mitigation System ([chapter 4.3.3.1](#)), BEKA Shell ([chapter 4.3.3.2](#)), casing of fire hoses⁷), and various configurations of the Hydro Sound Dampers ([chapter 4.5.1](#)) were tested. Some problems occurred during the project (WILKE et al. 2012). At a water depth of 8.5 m all of the five noise mitigation methods employed close to the pile achieved broadband noise mitigations in the range of only 4-6 dB which were much lower than previously expected. These findings are explained by the prevailing soil conditions with lens-shaped interglacial clay enclosures which might have reflected the sound waves emitted during pile driving into the water column, thereby increasing the overall underwater noise level. Furthermore, the characteristics of the test pile are not representative for offshore wind farm locations since the test pile was already anchored firmly about 65 m deep in the seabed and was strongly encrusted. Thus the energy (and also sound) is radiated by the pile in a different manner compared to a pile actively driven into the ground. This can be deduced from the result that in the far field (at 375 m and 750 m) the measured portion of the seismic wave coupled to the water (“preblow”, [Figure 2](#)) was very high (about 1/3 of the amplitude from water-borne radiation) compared to other locations (about 1/10 of the amplitude from water-borne radiation). Additionally to the embedment of the pile the static load of the noise mitigation systems on top of the pile might have increased coupling of sound energy to the ground. As the ground coupling occurs at

⁷ Although technically feasible, the concept of a casing of fire hoses with several layers of hoses fixed to frames has not resulted in the development of a commercial application.

low frequencies, the broadband values measured in the project were limited to frequencies above 125 Hz in order to evaluate this effect. Hence the noise reduction potential without this effect at the specific location can be increased by 2-3 dB (WILKE et al. 2012). The mitigation levels mentioned in [chapter 4](#) are far-field measurements without correction.

Measurements in the near field revealed a higher broadband noise reduction (5-8 dB at 13 m distance and 7-16 dB at 6 m distance) than measurements at 750 m, the relevant distance for the 160 dB threshold level. Possibly re-coupling of sound from the sediment to the water is lower at close range to the pile. However, when only the sound pressure is measured, near-field measurements are prone to large uncertainties due to the high blind portion of the acoustic capacity, which does not contribute significantly to the sound pressure in the far field.

The acoustic coupling of the seismic wave to the water column is currently subject to scientific research (e.g., *BMU* funded R&D project *BORA*, Calculation of offshore pile driving noise) ([chapter 6](#)). A profound modelling/simulation of the noise emission by the pile is possible only when the far-field and near-field effects are known.

In addition to German research projects, American studies concerning the protection of endangered fish species such as salmon and sturgeon in connection with bridge construction projects have also been relevant for the development of advanced noise mitigation methods (e.g. CALTRANS 2011, 2003, 2007, 2009). However, mitigation systems were deployed in very shallow water in most of these investigations, and measurement positions were usually much closer to the pile than in German investigations. Therefore these results cannot simply be transferred to the situation in the German exclusive economic zone (EEZ).

When presenting the different noise mitigation methods in [chapters 4.2](#) to [4.5](#), the measured noise reduction - if available - is provided as a broadband value together with the frequency range of maximum reduction. The range of maximum reduction is crucial for the resulting overall level. However, in many studies the results are only given as maximum reduction values or as an interval of results in a certain frequency range. These values are not directly comparable to broadband sum levels. If available, the resulting noise reduction is also given as a diagram of third octave band spectra. Whenever possible, the sound levels given correspond to the levels defined in DIN standard 1320. As decibel values are normally given as whole numbers, all results are rounded in this study even if they are given with decimal places in the original reports.

4.2 Bubble Curtains

A bubble curtain is formed around a pile by freely rising bubbles created by compressed air injected into the water through a ring of perforated pipes encircling the pile. This technique has been applied as an effective noise mitigation technique in several experimental and practical setups (e.g., CALTRANS 2003, GRIEBMANN et al. 2009, BETKE & MATUSCHEK 2010). Due to the large difference in density and sound velocity between water and air there is a considerable impedance mismatch. As air in contrast to water is compressible, air bubbles in water change the compressibility of the water and by this the propagation velocity of sound within the media. Sound stimulation of gas bubbles at or close to their resonance frequency effectively reduces the amplitude of the radiated sound wave by means of scattering and absorption effects. At resonance frequencies the effective scattering and absorption effect of a gas bubble in water is about 1,000-fold higher than the effect that would be expected simply from its geometrical dimension. A visual picture of a gas bubble is that of a hole with very low impedance compared to the surrounding medium (water). This hole disturbs the incidence of a sound field in a wider range around the gas bubble. In a bubble curtain, the interaction among the multitude of gas bubbles increases their noise reduction potential. And this is one of the reasons why bubble curtains attenuate sound waves so effectively (ELMER et al. 2007a, GRIEBMANN et al. 2009).

Any additional effects are hard to quantify since there are only few insights into the special mode of action of bubble curtains and their major components (e.g. air supply, bubble dimensions, distribution of bubbles as well as expansion and splitting of rising bubbles): It may be assumed that the sound energy which propagates directionally into the bubble curtain is reflected non-directional, thereby reducing the sound energy. Multiple reflection of sound at the surface of several neighbouring gas bubbles in water might also reflect wave lengths which are linked to the width of the bubble curtain. Therefore the wider the bubble curtain broadens into a v-shape close to the water surface, the more effective is the bubble curtain at lower frequencies. Currently it is not possible to give an exact analytical calculation of this phenomenon (WILKE et al. 2012).

NEHLS et al. (2007) already summarised the results of studies on the experimental application of various bubble curtains available at that time (WÜRSIG et al. 2000, CALTRANS 2001, CALTRANS 2003, VAGLE 2003, PETRIE 2005). This report therefore focusses on recent results.

4.2.1 Big Bubble Curtain

A big bubble curtain (BBC) is a ring of perforated pipes positioned on the sea floor around the foundation to be piled. This can either be a monopile, a tripile, a tripod or a jacket. Compressors located on the construction vessel or on a platform feed air into the pipe. The air passes into the water column by regularly arranged holes. Freely rising bubbles form a large curtain around the entire structure, thus shielding the environment from the noise source (Figure 4).

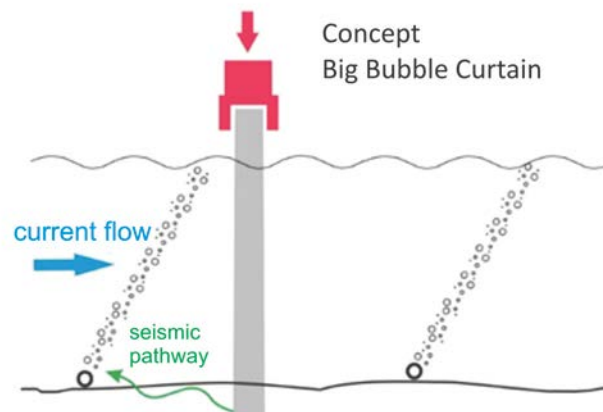

Figure 4: Concept of the big bubble curtain (source: JÖRG RUSTEMEIER, ISD, modified)

4.2.1.1 Experience with Big Bubble Curtains

Big bubble curtains have been applied in several projects under offshore conditions in the German North Sea since 2008 (Table 3). During the construction of the research platform *FINO 3* a noise reduction by 12 dB (SEL) and approx. 14 dB (peak) was achieved with best results in the frequency range around 2 kHz (GRIEBMANN 2009). Most recent results are derived from the BMU-funded research project „*Hydroschall-OFF BWII*“ at the commercial wind farm *Borkum West II* (renamed later to *Trianel Offshore Wind Farm Borkum*) (BELLMANN 2012, MENTRUP 2012, PEHLKE et al. 2012, VERFUß 2012). In autumn 2011 and spring 2012 various experimental setups of an improved version of the BBC were applied during the construction of 40 tripods using the pre-piling procedure. Noise measurements were conducted in the course of the regular construction process, thus piling proceeded independently of the installation of the bubble curtain. In other words, when the BBC was not properly installed before deployment of the jack-up barge on the site, piling was done without noise mitigation (PEHLKE et al. 2012).

The pipe-laying vessel has two complete redundant bubble curtain systems on board (Figure 5). In this project, the BBC was installed before the jack-up barge arrived at the location. The pipe-laying

vessel positioned one nozzle pipe ring around the first location and the second ring around the next location but one. For this purpose the flexible pipe weighted by a solid chain was uncoiled from the winch and lowered to the sea bed over the stern of the vessel. The pipe-laying vessel took a position that allowed connection of the air supply pipes to the four compressors aboard the vessel (PEHLKE et al. 2012).

Two different pipe configurations were tested which differed in hole diameter and distance between individual holes (“small distance”: hole diameter 1.5 mm and distance between holes 0.3 m; “large distance”: hole diameter 3.5 mm and distance between holes 1.5 m) (PEHLKE et al. 2012). Best results were achieved with the configuration “small distance” with a noise reduction of 11-15 dB (SEL) and 8-13 dB (peak) (BELLMANN 2012). [Figure 7](#) presents the positive correlation between air quantity (air supplied by one, two or three compressors) and the noise reduction achieved (BELLMANN 2012).

Table 3: Applications of big bubble curtains (BBC) in the German North Sea (n. s. = not specified)

Project (construction)	water depth (m)	foundation type	characteristics of bubble curtain	noise reduction (broad-band level)	reference
<i>FINO 3</i> (2008)	23	4.7 m monopiles	hexagonal BBC at 70 m from pile	12 dB (SEL) 14 dB (peak)	GRIERMANN (2009)
<i>Borkum West II</i> (2012)	26-33	tripods (pre-piling), pile diameter 2.5 m	oval BBC at 70-90 m from pile, different set-ups tested (e.g. variation of distance and diameter of holes, two half-circles)	11-15 dB (SEL) 8-13 dB (peak)	BELLMANN (2012)
<i>Nordsee Ost</i> (under construction)	22-25	4-legged jackets (post-piling)	installation of BBC by pipe-laying vessel	n. s.	www.rwenordsee.com
<i>Global Tech 1</i> (under construction)	39-41	tripods	installation of BBC by pipe-laying vessel	n. s.	http://www.globaltechone.de/
<i>Dan Tysk</i> (under construction)	21-32	monopiles about 6 m	installation of double BBC by pipe-laying vessel, 12-14 m between pipes	n. s.	http://www.dantysk.de/
<i>Meerwind Südost</i> (under construction)	23-26	monopiles	installation of double BBC by pipe-laying vessel, about 20 m between pipes	n. s.	http://www.windmw.de



Figure 5: BBC by *Hydrotechnik Lübeck* as applied at the OWF *Borkum West II*. Winch with nozzle pipe on pipe-laying vessel (left), and underwater photo during test in the Baltic Sea (right) (source: PEHLKE et al. 2012)



Figure 6: Application of a BBC by *Hydrotechnik Lübeck* at the OWF *Borkum West II* (photo: *Trianel GmbH/Lang*)

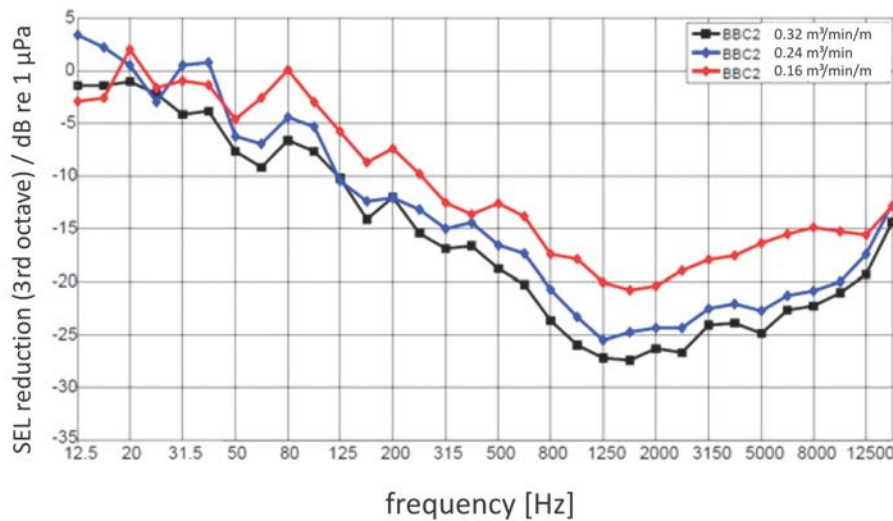

Figure 7: Noise reduction achieved by a BBC at the OWF *Borkum West II* as a function of air supply (source: BELLMANN 2012, modified)

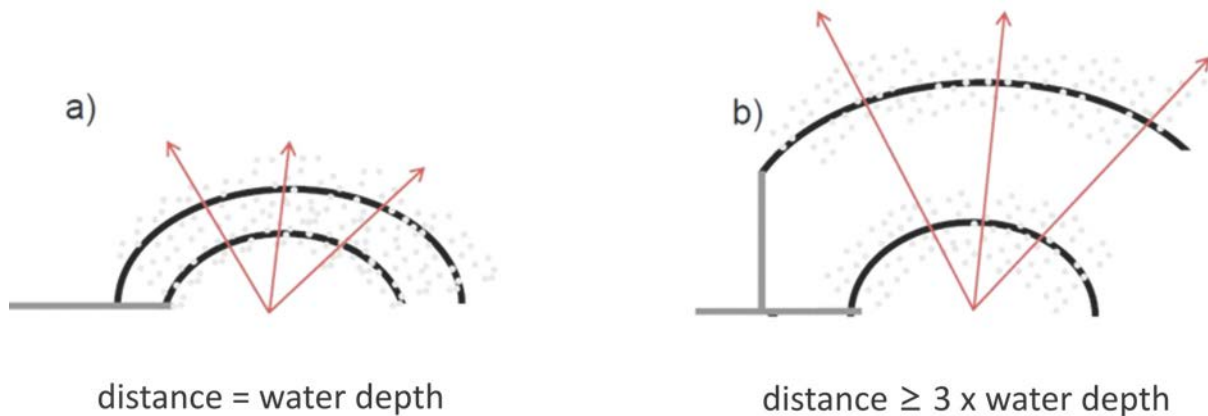

Figure 8: Schematic drawing of a double bubble curtain from two half-circles a) small distance → both bubble curtains unite, b) large distance → formation of two separate bubble curtains (source: BELL-MANN 2012, modified)

Additional tests were performed with a double BBC, which however could only be installed as two half-circles shielding the sound source only in one direction (Figure 8). The results revealed that a double bubble curtain can increase the reduction achieved by a single bubble curtain. Best results of 17 dB (SEL) and 21 dB (peak) were achieved when the distance between both nozzle pipes (80 m) was three times the water depth, thereby resulting in the formation of two separate bubble curtains (Figure 8). With a distance of 25 m between the pipes both bubble curtains united to one single bubble curtain, resulting in a noise reduction by 16 dB (SEL) and 19 dB (peak) which was intermediate between the configurations of a single and a double BC with a larger distance between pipes (HEPPER 2012).

4.2.2 Little Bubble Curtain: Several Variations

Unlike those of the BBC, the perforated pipes of little bubble curtains (LBC) are not positioned at the sea floor, but surround the pile in a close fit. Several variations of little bubble curtains have been developed.

Variations of Little Bubble Curtains: Layered Ring System

The concept of a little layered bubble curtain uses multiple layers of perforated pipes which surround the pile in a ring-shaped arrangement (Figure 9).

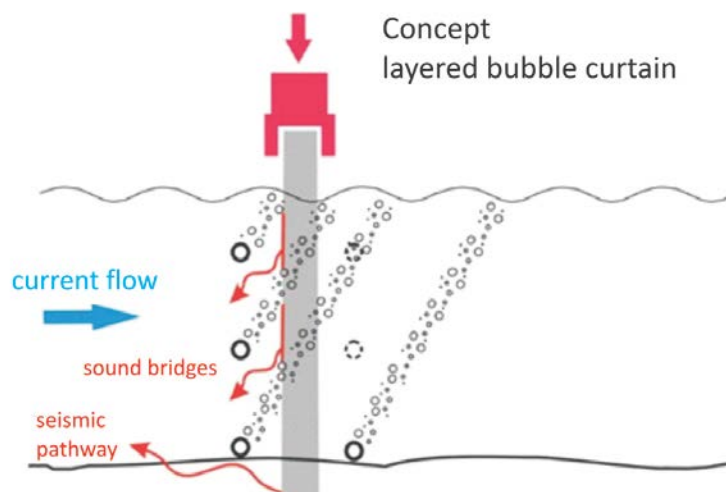

Figure 9: Concept of a layered bubble curtain (source: JÖRG RUSTEMEIER, ISD Hannover, modified).



Figure 10: Little bubble curtain, layered ring system. Left: Tripod for the OWF *alpha ventus* with pre-installed lower unit (source: *Hydrotechnik Lübeck GmbH* in: GRIEBMANN et al. 2010). Right: Transport of mobile unit to the OWF *Baltic II* (source: ZERBST & RUSTEMEIER 2011)

A bubble curtain of two units of horizontally arranged perforated rings was planned to be employed at the OWF *alpha ventus* in 2009. A pre-installed lower unit was permanently fixed to the foundation, whereas the upper unit assembled of several rings of perforated air pipes was mobile (Figure 10). The upper unit however was not employed until the piling of a test pile at the OWF *Baltic II* in 2011 (chapter 4.2.2.1). Depending on parameters such as water depth, distance between and diameter of pipe rings, the overall length of the pipes within a little bubble curtain may possibly be longer than that of a big bubble curtain.

Variations of Little Bubble Curtains: Confined Bubble Curtain⁸

The determining feature of a confined bubble curtain is an additional casing around the area of rising air bubbles. The casing may consist of plastic or fabric or of a rigid pipe with a large diameter. The noise mitigating properties of the system are not essentially affected by the casing material, i.e. steel and fabric are equally effective (CALTRANS 2009).

A telescopic layered confined bubble curtain by *Weyres Offshore* prevents the bubbles from drifting away by a confinement of guiding plates (see also chapter 4.2.2.1) (WILKE et al. 2012). A bubble curtain up to 1.8 m wide is produced by two concentric air outlet rings arranged on a 0.5 m flange. Based on calculations this arrangement is more effective than only one ring alone. The inner surface of the guiding plates is coated with a closed-cell foam material (5 cm *Styrodur*), thereby incorporating the casing material into the damping effect⁹. By applying a construction with the lower pipe on the bottom of a tub with a height of 2.6 m (Figure 11 right) that serves as a lateral sound protection wall, possible sound leakages between the nozzles can be shielded (BERNHARD WEYRES, *Weyres Offshore*, Daleiden, pers. comm.).

⁸ Combined systems, which include confined bubble curtains as an additional noise mitigation measure (*IHC Noise Mitigation System*, *Weyres BEKA Shell*), are introduced in chapter 4.3.

⁹ This additional element would, strictly speaking, shift the system to the category of combined systems.

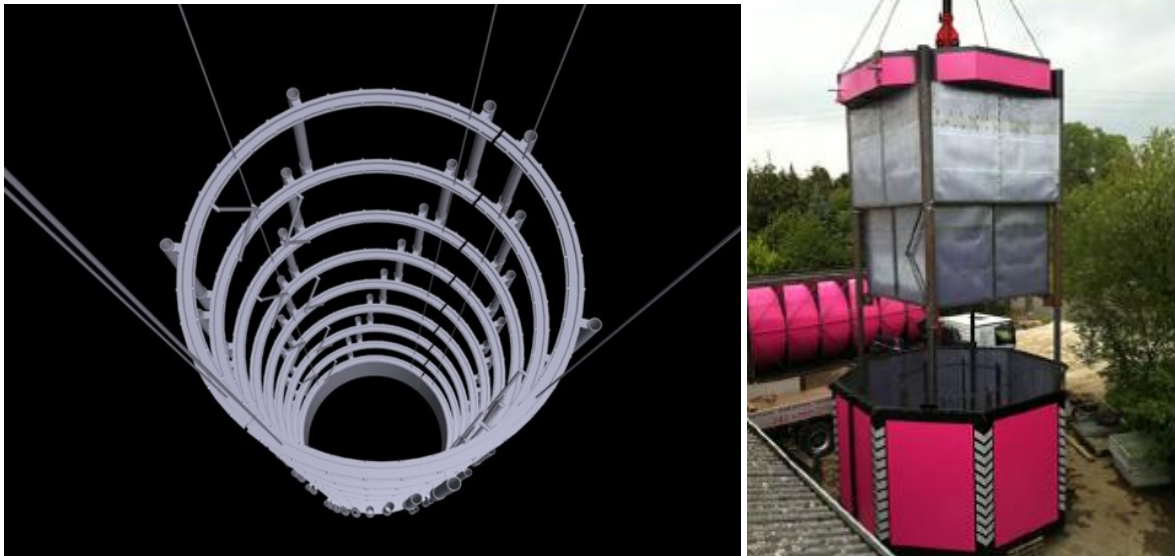

Figure 11: Layered and confined bubble curtain by *Weyres Offshore*. Principle of the layered arrangement of the pipes (left) (source: <http://www.weyres-offshore.de/>) and telescopic extended system (right) (source: WILKE et al. 2012, photo: B. WEYRES)

Little Bubble Curtain of Vertical Hoses (SBC: Small Bubble Curtain)

A vertical arrangement of a number of perforated pipes or hoses around the pile (SBC) as constructed by *MENCK* for the *OWF BARD Offshore 1* (Figure 12) (see also chapter 4.2.2.1) is also supposed to prevent the formation of sound leakages, as there is no horizontal interspace between the perforated rings. In this specific case tidal currents in horizontal direction and the upwelling zone of air bubbles with complex flow characteristics help close the bubble curtain completely around the pile (STEINHAGEN 2012).



Figure 12: Little bubble curtain of vertical hoses (SBC of *MENCK/BARD*). Concept tested at *OFT 1* (left and middle, see text) and improved concept for *OFT 2* (right) (source: STEINHAGEN 2012)

4.2.2.1 Experiences with Little Bubble Curtains

Variations of Little Bubble Curtains: Layered Ring System

A layered bubble curtain was tested during the construction of the German OWF *alpha ventus* in June 2009 (GRIEBMANN et al. 2010, BETKE & MATUSCHEK 2010). A tripod was anchored with 2.6 m piles by impact pile driving. The water depth was about 30 m. Only a pre-installed lower part of the layered bubble curtain's tube system could be activated (Figure 10). The additional mobile upper unit could not be installed due to unfavourable weather conditions. Thus, the tidal current caused the bubbles to drift away, resulting in large unwanted sound leakage which greatly reduced the system's effectiveness. An effective noise reduction was only achieved the direction of flow of the tidal current (BETKE & MATUSCHEK 2010). In this direction the sound level was reduced by about 12 dB (SEL) and 14 dB (peak) with best results at frequencies above 300 Hz (GRIEBMANN et al. 2010). These values correspond to the noise reduction achieved by the BBC (chapter 4.2.1.1) (GRIEBMANN 2009), but they are below the reduction measured during piling of the Benicia-Martinez Bridge Northeast of San Francisco with a multilevel system „bubble tree“ (CALTRANS 2007). Noise reduction with this system was 20-25 dB (SEL) or 19-33 dB (peak). As the water depth was only 12-15 m and the measuring distance was small (50-100 m), the results are not directly comparable.

In January 2011, the upper mobile unit of the layered ring system that was initially constructed for the OWF *alpha ventus* was employed at a test pile at the OWF *Baltic II* (\varnothing 1.5 m, length 45 m, wall thickness 50 mm, water depth 27.5 m) (Figure 10). The noise mitigation unit was fixed to the jack-up platform and afterwards the monopile was positioned into the bubble curtain that extended from the seafloor to the water surface (ZERBST & RUSTEMEIER 2011). During pile driving by IHC S-1200 hammer, sound measurements were conducted using two different systems. Firstly, hydrophones were anchored 2 m above the sea floor (SCHULTZ-VON GLAHN 2011), secondly, ship-based measurements were conducted at water depths of 11 m and 23 m (ZERBST & RUSTEMEIER 2011).

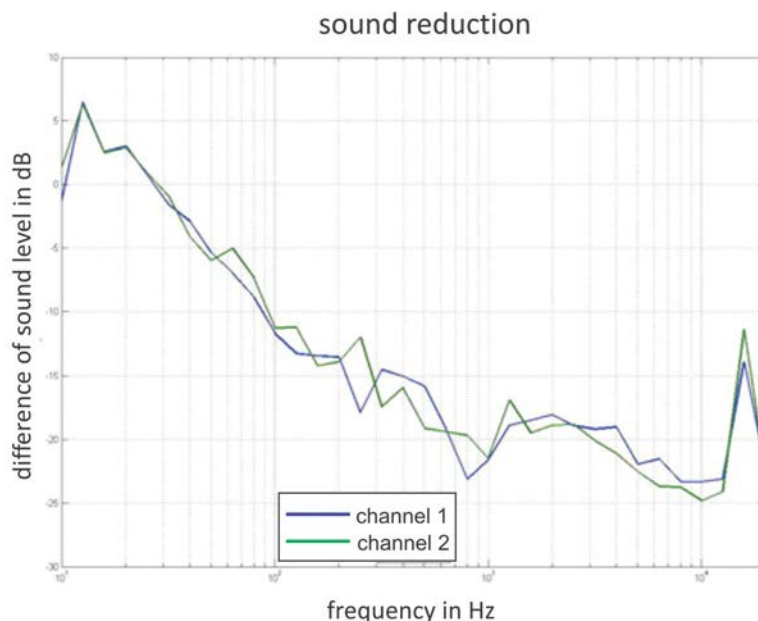

Figure 13: Noise reduction provided by a little bubble curtain at OWF *Baltic II* as a function of frequency (source: ZERBST & RUSTEMEIER 2011, modified)

Without noise mitigation system applied, maximum sound levels measured with the anchored system were 168 dB (SEL) (SCHULTZ VON GLAHN 2011) and on average 166-170 dB (SEL) as shown by the ship-based system (ZERBST & RUSTEMEIER 2011). The noise reduction achieved by means of the little bubble curtain increased continuously from frequencies of approximately 25 Hz and was highest at

frequencies of 1-10 kHz (Figure 14). The broadband noise reduction at 750 m as measured by the anchored hydrophones was 15 dB (SEL) (SCHULTZ-VON GLAHN 2011), whereas the ship-based measurements revealed a reduction by 11-13 dB (SEL) (ZERBST & RUSTEMEIER 2011). It has to be noted that the reference value without noise mitigation was not determined at the same pile D06, but at pile D05, which was piled at nearly identical water depth, under comparable soil conditions, using the same impact energy and had a similar time-dependent penetration depth. Thus, identical sound emissions were assumed at both piles (SCHULTZ-VON GLAHN 2011, ZERBST & RUSTEMEIER 2011).

Variations of Little Bubble Curtains: Confined System

Up to now, confined bubble curtains have been applied in shallow waters at locations with high current velocities where it was to be expected that the air bubbles would drift away from the pile. The systems have demonstrated a high noise reduction potential, however until recently experience existed from shallow waters and short distances to the shore only (CALTRANS 2003, WILKE et al. 2012). The results achieved under these conditions cannot be directly generalised to offshore conditions.

During the *ESRa Project* in August 2011, the layered and confined bubble curtain by *Weyres Offshore* was used (Figure 11). The base area of the system was an octagon with a diameter of 5.25 m. Its weight was 7.4 t. The pipes of the upper level together with their guiding plates were floatable, thereby automatically floating to the surface once the base tub was placed on the sea floor. Noise measurements showed that the broadband noise level was reduced by 4-5 dB (SEL) (Figure 14) (WILKE et al. 2012). However, in order to interpret the low noise reduction measured in the framework of *ESRa*, the problems encountered during the project have to be considered (see chapter 4.1).

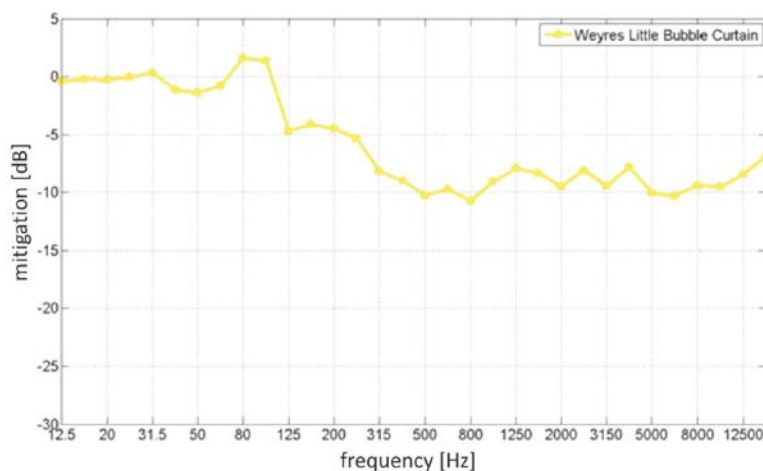

Figure 14: Difference spectrum (reduction of sound transmission) of the layered and confined bubble curtain by *Weyres Offshore* as measured in the *ESRa* project (measurement distance 375 m) (source: WILKE et al. 2012)

Variations of Little Bubble Curtains: Little Bubble Curtain of Vertical Hoses

An improved concept of vertically arranged pipes, the small bubble curtain (SBC) by *MENCK* and *BARD*, was tested during the offshore test 1 (OFT 1) at the OWF *BARD Offshore 1* in autumn 2011. In this system, the pipes are flexibly attached to the piling frame between an upper and a lower ring (Figure 12, left). The entire system was placed over the pile from above. The installation process took six hours. Air was supplied by six compressors; however, results demonstrated that four would have been sufficient. The resulting noise reduction differed among the various configurations (air volume, number of pipes) tested and reached a maximum of 14 dB (SEL) (KUMBARTZKY 2012, STEINHAGEN 2012).

Based on the results achieved during the project *BARD OFT 1*, the SBC was improved (Figure 12, right) and deployed in September 2012 during the BMU funded research project *BARD OFT 2* in the North Sea (STEINHAGEN 2012). The new design uses flexible tubes instead of rigid pipes which are anchored to the sea bottom by means of a dead-weight ring. The tubes can be uncoiled from winches on the top (Figure 12, right). This version of the SBC was applied in combination with a pile guiding frame of the barge “Windlift” (KUMBARTZKY 2012). The second test system OFT 2 was specially designed to meet the demands during the installation of *BARD* tripile foundations. It is characterised by the use of standard components and easy handling. An analysis of the measuring results is not available yet (STEINHAGEN 2012).

4.2.3 Valuation of Bubble Curtains

4.2.3.1 Noise Mitigation

Bubble curtains have been applied as an effective noise mitigation technique in several practical (chapter 4.2.1.1 and 4.2.2.1) and experimental (APPLIED PHYSICAL SCIENCES 2010) setups. Models of the three propagation pathways (air path, water path, seismic path) for pile driving noise of large monopiles have demonstrated that the direct structure-borne radiation (in water) dominates in nearly the whole frequency range (100 Hz to 1 kHz) over the indirect seismic or airborne pathways (Figure 15). Hence, noise mitigation techniques primarily have to be designed to mitigate the structure-borne radiation. However, the seismic contribution is the limiting factor for the overall effectiveness of treating the structure-borne radiation path in many cases (APPLIED PHYSICAL SCIENCES 2010). Therefore, also considering the seismic pathway in noise mitigation systems affords some potential for further improvements. Other options for optimisation arise from the fact that the noise mitigation of bubble curtains is frequency dependent.

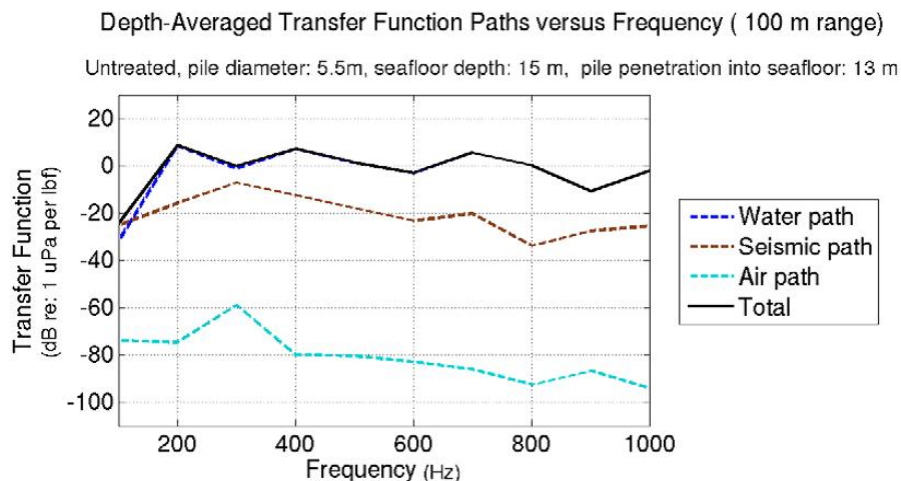

Figure 15: Representative sound transmission path components for an untreated pile (source: APPLIED PHYSICAL SCIENCES 2010)

The various bubble curtain concepts have different advantages and disadvantages with regard to their noise reduction potential:

Big Bubble Curtain

When a BBC is applied the pile is entirely surrounded by air bubbles even under tidal conditions as a consequence of the large diameter of the system together with the application of an elliptical nozzle pipe as in the OWF *Borkum West II*. The noise reduction is not interfered with by sound leakages (see also Figure 6). The amount of sound energy that re-enters the water column via the seismic path

(NEDWELL & HOWELL 2004, APPLIED PHYSICAL SCIENCES 2010) is possibly also reduced due to the large diameter of the system. In cases where a higher noise reduction is required (e.g. for large monopiles) a double bubble curtain offers an even higher reduction potential. When the distance between both pipes is large enough to allow for the formation of two separate bubble curtains a higher reduction can be achieved than with a smaller distance, when both bubble curtains unite.

Variations of Little Bubble Curtains

The seismic contribution to the propagation of the sound is not reduced by any of the variations of the little bubble curtain. Intensive current flows may reduce the effectiveness of the system as air bubbles drift away and sound leakages develop when the pile is not completely enclosed by the bubble curtain (ISD 2010). However, this effect may be minimised by varying the interspace between pipe layers, the distance of the perforations in the pipe or the width of the bubble curtain. Using the pre-piling procedure for jackets or tripods prevents structure-borne radiation from being transmitted from cross beams when the bubble curtain does not form a complete enclosure. With this procedure, the piles are driven through a template prior to attaching and grouting¹⁰ the jacket or tripod. The pre-piling procedure also simplifies the handling of telescopic layered bubble curtains as the process is identical to the procedure with small monopiles.

Variations of Little Bubble Curtains: Layered Ring System

Other than with a BBC, when applying a layered ring system of a little bubble curtain, sound leakages may occur when the gas bubbles are caused to drift away by current flow, thus greatly reducing the effectiveness of the LBC (Figure 9) (ISD 2010). A potential problem occurs with tripods and jackets: the structure-borne noise of the pile can be coupled to the jacket or tripod at the pile sleeve and may be further transmitted to the water column outside the bubble curtain surrounding the pile. Various concepts have been developed to minimise the duration of the bubble curtain's installation such as telescopic systems or various attachments, e.g. at the gripper of the crane or at the piling frame. The noise levels measured with a layered ring system as applied at the OWF *Baltic II* revealed a good noise reduction even in the critical frequency range of 125-1,000 Hz, where the major energy of the pile driving signal is emitted (Figure 13) (SCHULTZ-VON GLAHN 2011, ZERBST & RUSTEMEIER 2011).

Variations of Little Bubble Curtains: Confined System

At locations with intensive current flows like in the North Sea the confinement must be stable enough to prevent it from touching the pile and generating sound leakages. In the literature it is contradictory whether a sharp boundary of the bubble curtain created by the confinement results in a better or worse noise reduction. GRANDJEAN et al. (2011) expect an improved noise reduction compared to diffuse distributions of the air bubbles. However, WILKE et al. (2012) state that in contrast a broad V-shaped bubble fan has a positive effect on the attenuation of low frequencies by means of multiple reflections.

Variations of Little Bubble Curtains: Little Bubble Curtain of Vertical Hoses

A vertical arrangement of nozzle pipes or hoses, such as tested by MENCK at the OWF *BARD Offshore 1* (Figure 12), prevents the creation of sound leakages, because no horizontal gaps are present between hoses.

¹⁰ grouting = pressing operation of cement

4.2.3.2 Development Status

Many studies have revealed that air bubbles in water effectively reduce the propagation of underwater sound. As bubble curtains have been successfully applied in many experiments and practical set-ups, their suitability for reducing sound emissions can be taken for granted.

Big Bubble Curtain

Based on the results achieved in two applications in Germany accompanied by research projects it can be argued that today the BBC is the best-tested and the most thoroughly proven noise mitigation technique for foundations of OWFs. This is valid at least for frame constructions (jackets, tripods) and small monopiles currently used as it has been demonstrated several times - also in a broad range of studies under various conditions in other countries - that a significant noise reduction was achieved which is suitable to meet the 160 dB threshold level.

The suitability of big bubble curtains for reducing noise emissions has been demonstrated by models as well as by achieved noise reduction in scientific investigations and, last but not least, by practical applications. Also, the system's robustness and its practicability under offshore conditions has been demonstrated several times. An important aspect for an economic application is the adaptation to the respective offshore operations layout and to the construction schedule. Problems encountered in the past (*FINO 3*) were solved by an improved application technology. By means of applying the bubble curtain before or after positioning the jack-up barge and by connecting the compressors before or after the installation of the mitigation system, flexibility with regard to various construction schedules is warranted.

The application of a big bubble curtain makes it possible to meet the 160 dB threshold level up to certain impact energy (depending e.g. on pile diameter) and for certain environmental conditions. A double BBC offers an option for larger monopiles. The investigations at the *OFW Borkum West II* have shown that a double bubble curtain achieved a higher noise reduction than a single bubble curtain. This variation is currently applied in two commercial projects ([Table 3](#)). A large distance between both bubble curtains seems to be crucial for a high noise reduction in order to prevent them from forming only one single curtain due to the v-shaped spreading in direction of the water surface. Further investigations and the development of a suitable installation technology are required for the double BBC.

During the *FINO 3* project some problems were encountered initially. Due to time-consuming and thus expensive installation by divers the construction process was delayed, and especially the flanging of 20 m pieces above the water surface turned out to be a problem. Recognising these problems has led to conceptual improvements of the system. The enhanced BBC systems are robust and can be installed directly from a vessel beforehand. A driven winch fitted with hydraulic or pneumatic brakes aids the circular laying of the pipe. The pipe-laying vessel has two complete redundant bubble curtain systems on board which can be installed revolvingly (CAY GRUNAU, Hydrotechnik Lübeck GmbH, pers. comm.; BERNHARD WEYRES, Weyres Offshore, Daleiden, pers. comm.). The systems are suitable for the prevailing depths and current velocities in the German EEZ.

The BBC in its improved version (compared to the one used at the platform *FINO 3*) was applied during the construction of the *OFW Borkum West II* from September 2011 to March 2012. It was demonstrated that the entire handling of the bubble curtain can be done independently of the jack-up rig. The deployment of the bubble curtain hampers neither the construction works nor the progress of the construction process as the mitigation system is installed prior to shifting the installation rig (BIOCONSULT-SH et al. 2012). However, the noise mitigation system was not effective at nine of 40 locations for various reasons (HEPPER 2012): In stormy weather the marker buoys of the air supply pipe were torn away so it was not found before piling started. In two cases the anchors of the instal-

lation barge were placed in such a way that it was no longer possible to lift the air supply pipe and connect it to compressors. Additionally, temperatures below zero made some compressors freeze, thereby reducing the effectiveness of the bubble curtain. In some of the current projects the BBC is installed right after positioning the installation barge and air is supplied from the start of the deployment process. This procedure probably helps prevent the above-mentioned causes of failure. The delay in the construction process is negligible as the mitigation system can be installed during the preparatory works for pile driving (BERNHARD WEYRES, *Weyres Offshore*, Daleiden, pers. comm.). The BBC has some future potential for optimisation. This applies to handling as well as to the system's effectiveness (e.g. air supply, bubble dimensions, distance and size of holes).

It has been repeatedly criticised that no certain level of noise reduction can be guaranteed. It will, however, not be possible to avoid uncertainties resulting from certain soil conditions or technical problems for any of the mitigation measures. But this does not affect the overall suitability of the proven system.

Variations of Little Bubble Curtains

The experience gained with the **layered ring system** applied at the OWF *alpha ventus* led to further improvements of the technology. These later systems use a multitude of vertically arranged nozzle pipes or tubes which are attached in a close fit to the pile (*MENCK/BARD*, [chapter 4.2.2.1](#)), or they make use of a casing (layered and confined LBC by *Weyres Offshore*, [chapter 4.2.2.1](#)) in order to prevent the bubbles from drifting away. The mobile layered upper unit of the *alpha ventus* system was applied for the first time at a test pile at the OWF *Baltic II* at 23 m depth, which was a full-scale test in intermediate water depth. The overall development of little bubble curtains corresponds to the pilot stage.

The **layered confined bubble curtain** was only investigated during the *ESRa* project. In addition to restrictions resulting from the geology and the specific situation of the test pile ([chapter 4.1](#)) which resulted in disappointing noise reduction levels, the significance of the tests was further restricted by the position in sheltered shallow water without tidal currents. Overall the development of the **little bubble curtain of vertical hoses (SBC)** is at the most advanced stage of development of all LBCs. The first offshore test with a 3.35 m pile resulted in a significant noise reduction of 14 dB (SEL) / 20 dB (peak) ([chapter 4.2.2.1](#)) thereby meeting the 160 dB threshold level. The results of the second offshore test with the improved system are expected shortly. This will complete the pilot stage. For the layered ring system and the layered confined bubble curtain a proof of their effectiveness under offshore conditions would be appropriate. No future plans for further tests are known.

All of the currently available bubble curtain systems are reusable as they have no pre-installed parts which would have to be left at the foundation structure (such as in [Figure 10, left](#)). The attachment to the pile is flexible, but technical modifications are required for each individual case. Bubble curtains can achieve a significant noise reduction. But a precondition is that the entire oscillating structure is surrounded by the bubble curtain.

The different variations of little bubble curtains currently available are robust and flexible in their application. The systems have to be adapted to each application (with respect to water depth, current velocity, pile diameter, attachment and details of the foundation structure, e.g. monopile, jacket or tripod). Thus, the little bubble curtain with vertical hoses is specifically designed to meet the demands of *BARD* tripile foundations. For the application with other foundation types specific modifications may be required.

To quickly and easily attach LBC systems to the piling frame or gripper and thus achieve a universal applicability, some further development work has to be done. When applying noise mitigation systems with frame constructions the pre-piling procedure can offer cost advantages compared to the post-piling method.

Major costs are generated by the supply of bubble curtains with compressed air. From a certain water depth and current velocity on a layered bubble curtain requires longer tubes, hence more air may be needed compared to a BBC. Therefore, an LBC is not necessarily cheaper than a BBC. Thus, the somewhat misleading¹¹ name “little” bubble curtain refers to the overall dimension and not the length of the nozzle pipe. A major cost saving potential is the reduction of the amount of air required. In order to calculate the costs of a noise mitigation system realistically other parameters such as logistics, required space on board of the vessel, service and costs of purchase must also be taken into account. Handling and operation of the mitigation technology is of major importance for all systems as this might result in a cost-intensive delay of the entire construction process.

Little bubble curtains have the potential to be applied in commercial OWFs shortly. The necessary components are already available on the market (e.g. for oil barriers of compressed air), but they have to be adapted to offshore applications.

Limiting Conditions for the Application

The application of the systems currently available on the market may be limited by the wave height if the compressors in use are placed on board a ship. From an inclination of 11-15° on problems may occur with the suction process of the oil, hence the devices are usually automatically shut-down. A possible solution would be to place the compressors on the stationary jack-up barge. Corresponding technical adaptations of the compressors are theoretically possible, however currently the industry does not see the market demand (CAY GRUNAU, *Hydrotechnik Lübeck GmbH*, pers. comm.). Future research projects should therefore also focus on the limiting conditions for the application of bubble curtains ([chapter 7](#)).

4.3 Isolation Casings

A simple isolation casing consists of a steel pipe around the pile reflecting a part of the noise back inside. More complex systems have additional layers containing air (foam, composites or bubbles freely rising inside, [Figure 16](#)) making use of the impedance mismatch between water and air. Thus absorption, scattering and dissipation effects are responsible for noise reduction (ELMER et al. 2007a, NEHLS et al. 2007). Similar to a bubble curtain, the basic principle of an isolation casing is the shielding effect of a complete casing around the noise generating structure. Other than with the bubble curtain, attenuation provided by an isolation casing results primarily from reflections at phase transitions (water-steel-air) and additional sound absorbing effects result from absorption at the air- and foam layers (ELMER et al. 2007a, NEHLS et al. 2007).

¹¹ A BBC of 70 m diameter requires 440 m nozzle pipe. For a layered LBC of 6 m diameter this value is exceeded from 12 layers onwards. For strong tidal currents a distance of 2 m among individual layers is realistic, thereby showing that at water depths of 24 m or more a layered LBC needs more compressors than a BBC (CAY GRUNAU, *Hydrotechnik Lübeck GmbH*, pers. comm.)



Figure 16: Isolation casing with additional bubble curtain between pile and isolation casing during piling of a 2.4 m pile at the Benicia-Martinez Bridge, California (source: CALTRANS 2007)

Results from first simple experimental setups were poorly suited to meet the demands of offshore applications (SCHULTZ-VON GLAHN et al. 2006) and the results of shallow water application of isolation casings during bridge construction in the western US (CALTRANS 2009) could not be transferred to offshore conditions. In the meantime, further development resulted in commercial solutions specifically designed to meet the demands of offshore conditions (*IHC Noise Mitigation System*, [chapter 4.3.1](#), and *BEKA Shells*, [chapter 4.3.2](#)). They make use of various combinations of different materials. Isolation casings may also be combined with bubble curtains, which is a transition to the category of confined bubble curtains ([chapter 4.2.2](#)). If the interspace between double walls of the isolation casing is dewatered, thus forming an air-filled space, the principle corresponds to that of a cofferdam ([chapter 4.4](#)). An exact classification into one or the other category may not always be possible for such mixed systems.

4.3.1 *IHC Noise Mitigation System*

The **Noise Mitigation System (NMS)** developed by *IHC Offshore Systems* (The Netherlands) which has already been tested in a commercial OWF project consists of an acoustically decoupled double-wall isolation casing with an air filled interspace. An adjustable multi-layered bubble curtain between the NMS and the pile provides an additional noise barrier. Hence the NMS combines features of an isolation casing with those of a confined bubble curtain: shielding and reflection effects of a double-wall steel tube combined with the acoustic decoupling principle of a cofferdam by the air filled interspace combined with additional absorption and scattering effects resulting from the confined bubble curtain between pile and casing tube.

Extra features of the system NMS-6900 applied at the OWF *Riffgat* ([Figure 17](#)) are a multi-level and a multi-size bubble injection system. A pile guiding system consisting of an upper and a lower guiding keeps the pile in the centre of the NMS (VAN VESSEM 2012). The system is applicable to monopiles as well as for jackets und tripods, both in pre-piling and in post-piling procedure (VAN VESSEM 2012).

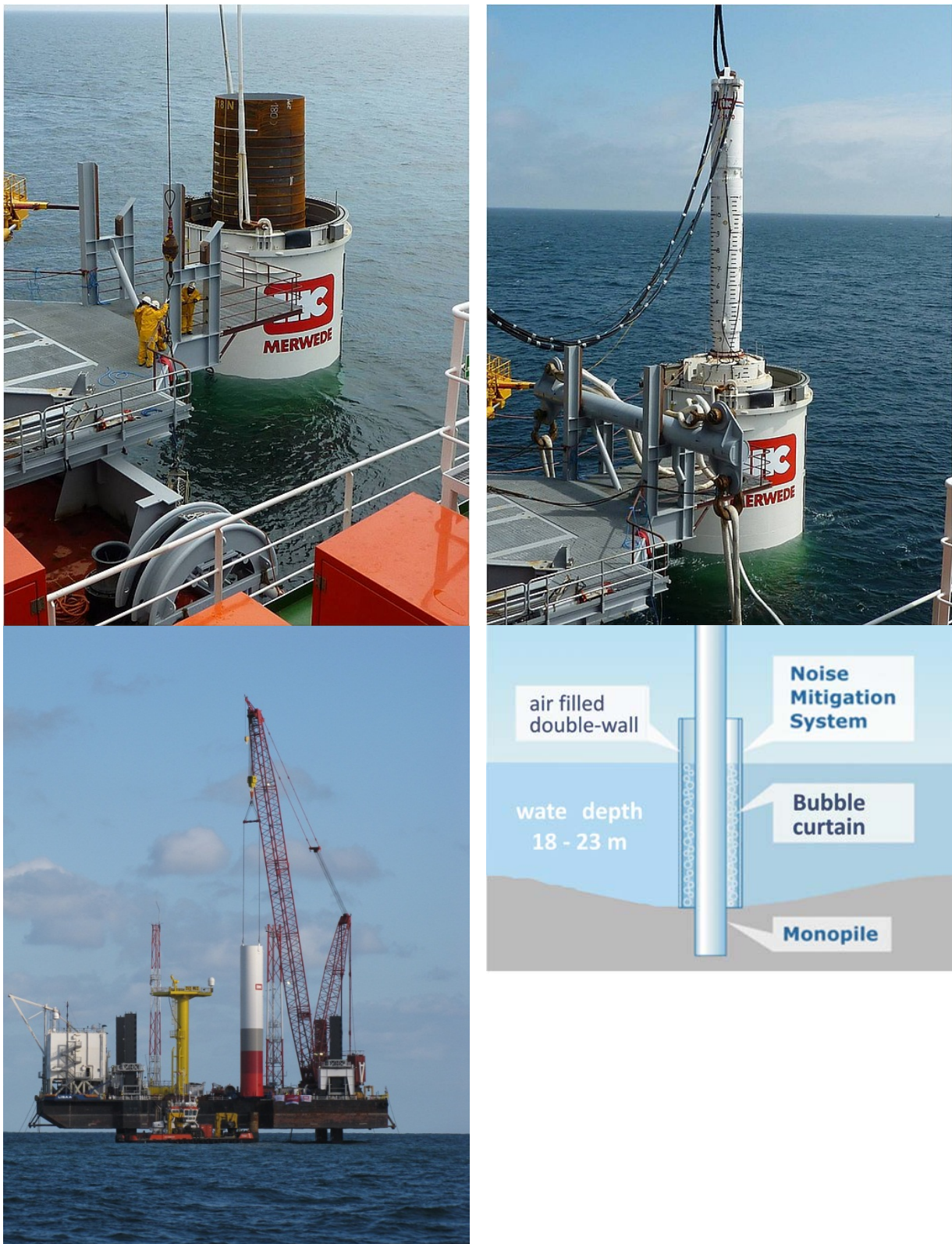

Figure 17: Application of the IHC Noise Mitigation System NMS 6900 at the OWF Riffgat (source: <http://www.riffgat.de>, modified)

4.3.2 BEKA Shells

The patented *BEKA Shells* by *Weyres Offshore* (Figure 18) constitute a combined system based on the principle of an isolation casing. It consists of multiple layers creating shielding, reflection and absorption effects. Two acoustically decoupled half-shells which are hydraulically movable relative to each other are closed around the erected pile and then lowered to the seabed. Two layered bubble curtains consisting of air bubbles of varying dimensions are generated within the 30 cm wide interspace between the inner wall and the pile and between two concentric isolation casing layers (each double-walled and acoustically decoupled by means of industrial vibration dampers). As the bubbles vary in their dimension, different frequency ranges of the noise spectrum are supposed to be attenuated. Flexible guide shims (rubber rolls) make sure that the pile is not in direct contact with the *BEKA Shell* and helps to keep up penetration during anchoring of the pile. The two concentric steel isolation casings, each 20 cm thick, are filled with a sound absorbing composite material and separated by 15 cm of water. The inner steel shells are coated with 5 cm layers of sound absorbing material. Sound mitigation shells at the lower end are supposed to penetrate into the ground, thereby decoupling the sound transmission along the seismic path (WEYRES 2012). The weight of a typical *BEKA Shell* for the application with a 6.5 m monopile in 30 m water depth is about 180 t (WILKE et al. 2012). The diameter of the *BEKA Shell* for the given example is about 2 m greater than that of the monopile itself.



Figure 18: *BEKA Shell* by *Weyres Offshore*: Left: Half-shells opened (source: <http://www.veyres-offshore.de/>). Right: During the installation in the *ESRa* project (source: WILKE et al. 2012, photo: PATRICE KUNTE)

4.3.3 Experience with Isolation Casings

During an *UBA* (*German Federal Environmental Agency*) funded research project, the effectiveness of several isolation casings (uncoated steel tube, rubber coat, coated with foam) was tested in 2006/2007 under laboratory and shallow water (8.5 m) conditions (SCHULTZ-VON GLAHN et al. 2006, ELMER et al. 2007a). A solid, double-walled plastic tube, filled with polyurethane foam, achieved the best results in laboratory experiments (Figure 19).

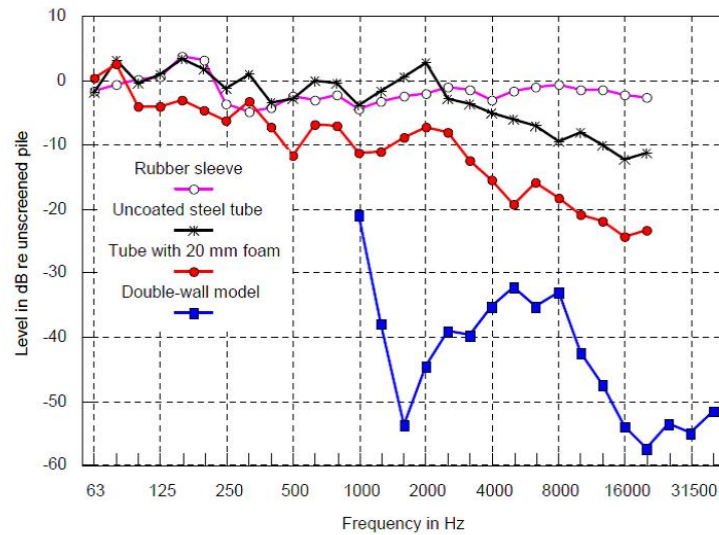

Figure 19: Noise reduction provided by different isolation casings in laboratory and shallow water experiments. Tests of the uncoated steel tube, the rubber sleeve and the foam-covered tube were performed at a test pile in the Baltic Sea using a hydraulic hammer. The double-wall model was tested with a piezo-electric beacon in a laboratory experiment. Due to the small dimension of the test pool, sound was only propagated above 1.000 Hz in this experiment (source: ELMER et al. 2007a)

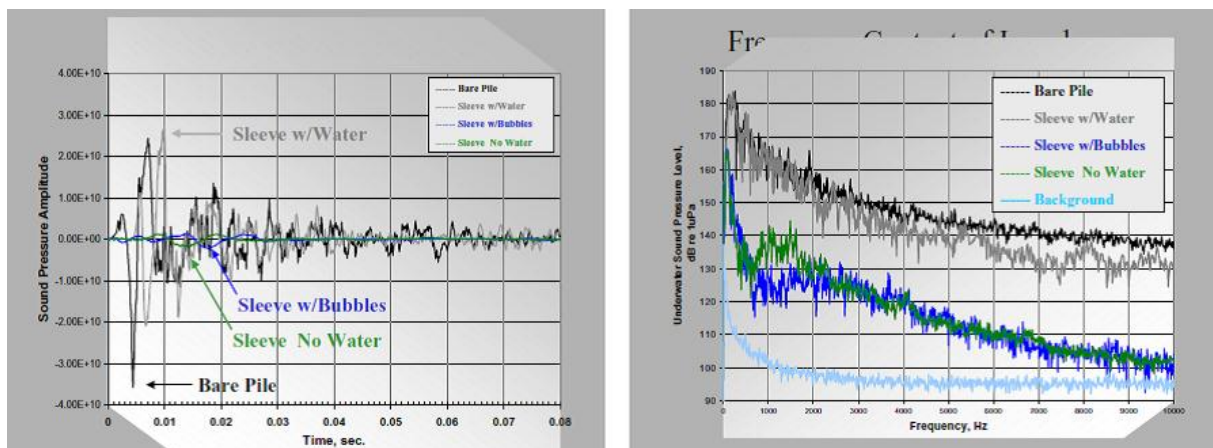

Figure 20: Noise reduction during piling of a 2.4 m pile with isolation casing (grey: water filled, dark blue: with bubble curtain between pile and isolation casing; green: dewatered) (source: CALTRANS 2007)

During pile driving at the Benicia-Martinez Bridge, California (\varnothing 2.4 m; max. impact energy 570 kJ), three different configurations of a steel isolation casing with a diameter of 3.7 m were tested (Figure 16, Figure 20). The **water filled** option only provided a noise reduction by about 0-2 dB. **Air bubbles** between pile and isolation casing improved the noise reduction up to 21 dB (SEL) or 23 dB (peak), measured at 54 m distance. This principle corresponds to that of a confined bubble curtain (chapter 4.2). A similar noise reduction was provided by the **dewatered** option, which corresponds to a cofferdam (chapter 4.4).

4.3.3.1 IHC Noise Mitigation System

Pilot tests of the NMS were performed among others at the Dutch OWF *Egmond aan Zee*, in the river De Noord (NL), in the *ESRa* project (chapter 4.1) and in the *FLOW* project (NL/D) during piling of piles with diameters ranging from 0.9 m to 3.5 m (Figure 21) (VAN VESSEM 2012). With smaller piles in shallow water (6 m), sound could be reduced in third octave bands between 150 Hz and 8 kHz by 20-27 dB (BOB JUNG, *IHC Hydrohammer*, Kinderdijk, NL, pers. comm.). During the *FLOW*-project, noise reduction values at two locations in the North Sea (met masts with a diameter of 3.35 m at a water depth of 25 m, *IHC S800* hammer) of 9 dB (*OWF Nordsee Ost*) and 11 dB (Ijmuiden) were measured (WILKE et al. 2012).

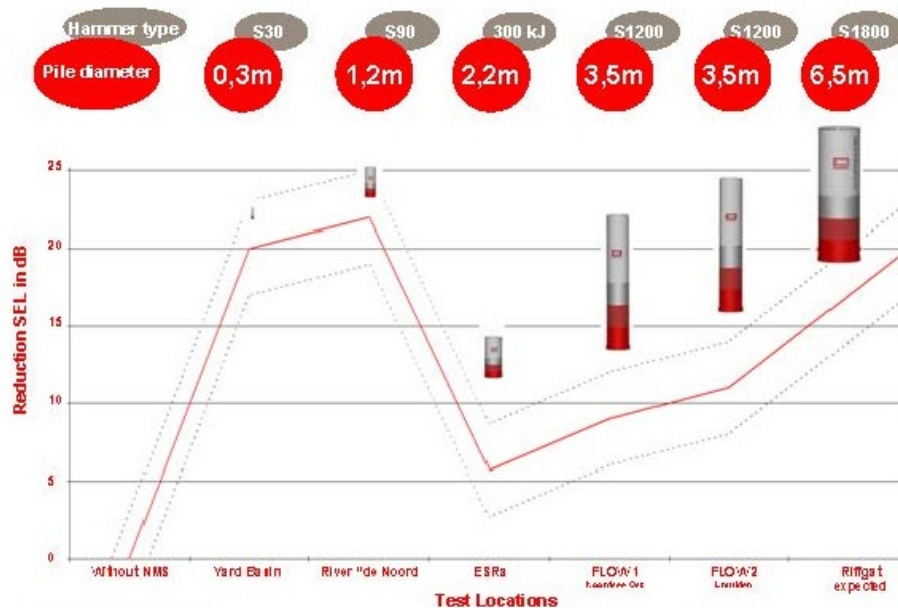

Figure 21: Noise reduction by the *IHC* Noise Mitigation System in various projects (courtesy of *IHC Merwede*)

During the *ESRa* project at an already driven test pile in the Baltic Sea, the *IHC* Noise Mitigation System (outer diameter 3.65 m, weight 30 t) provided an overall broadband noise reduction by 5-8 dB SEL (Figure 22). In contrast to the application at the *FLOW* project, where the double steel walls of the NMS were acoustically decoupled by means of plastic support brackets, the walls were still welded in the *ESRa* project. The resulting acoustic leakage is estimated to reduce the overall attenuation by 1 dB (WILKE et al. 2012). However, in order to interpret the low noise reduction potential measured in the framework of *ESRa*, the problems encountered during the project have to be considered (see chapter 4.1).

From June to September 2012 the *IHC NMS-6900* was deployed at the German 108 MW OWF *Riffgat* in the North Sea at water depths of 18-23 m. Penetration of the first 13-24 m of the total embedment depth of each of the monopiles (\varnothing 5.7 m resp. 6.5 m) was reached by vibratory pile driving (see chapter 5.1.1). A hydraulic hammer (*IHC hydrohammer S1800*) was only applied to reach the final embedment depth of 29-41 m. An *IHC NMS 6900* with an outer diameter of about 10 m served as noise mitigation system (Figure 17). Based on the results of the pilot tests, an overall noise reduction by about 20 dB SEL was expected (Figure 21). Sound measurements during the construction process were performed by GERKE & BELMANN (2012). Single event sound pressure levels varied between 162 and 166 dB (SEL) (Figure 23) and in total the 160 dB threshold level was exceeded by about 3 dB (SEL). It was noted that the louder impulses contained considerably more energy in the high frequency range which was attributed to the assumption that the pile penetrated harder components (e.g. sand with erratic boulders) within the soil during the piling process.

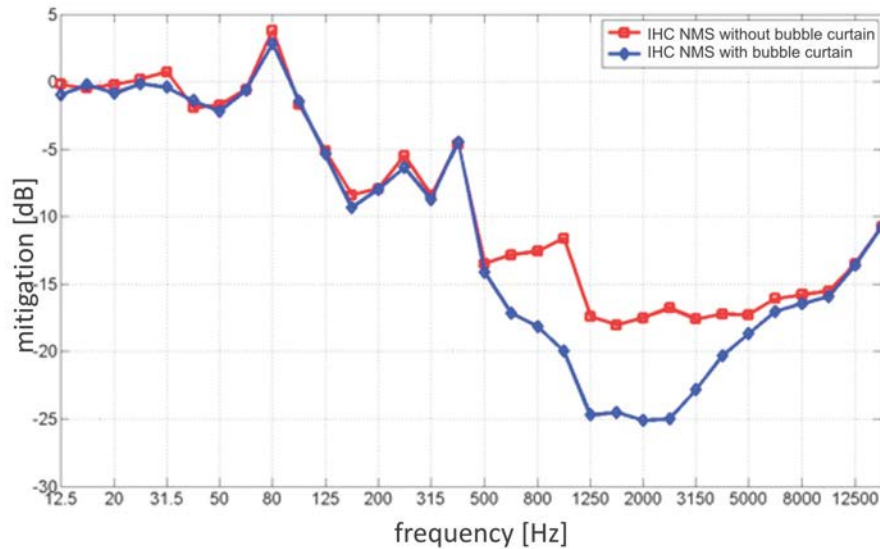

Figure 22: Difference spectrum (reduction of sound transmission) of the *IHC* Noise Mitigation System as measured in the *ESRa* project with and without inner bubble curtain (measurement distance 375 m) (source: WILKE et al. 2012, modified)

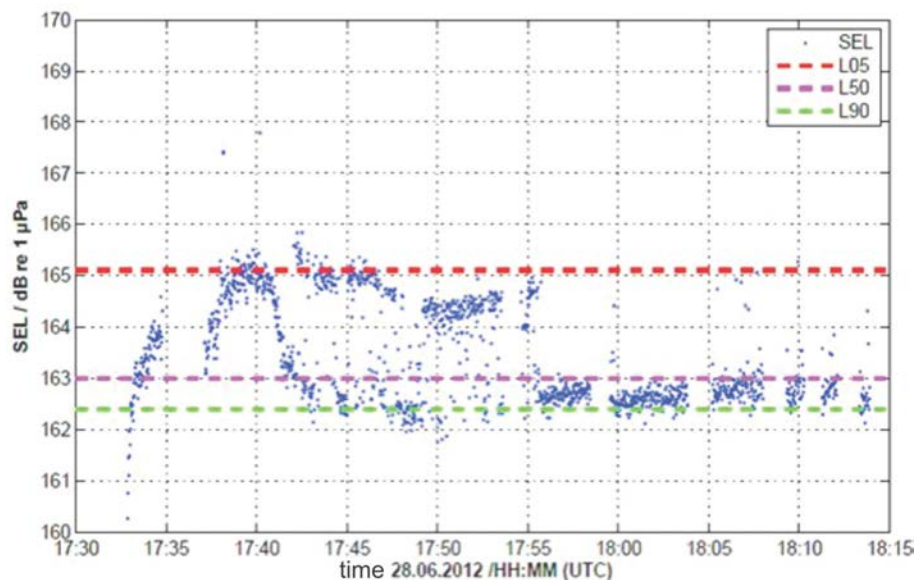

Figure 23: Broadband noise sum level during pile driving at the OWF *Riffgat* (pile R14, measurement at about 750 m distance; blue points: SEL of each of the 1,403 piling strikes; red, magenta and green dotted lines: percentile values of 5%, 50% and 90% of measurements) (source: GERKE & BELLMANN 2012, modified)

4.3.3.2 BEKA Shells

The noise reduction provided by the *BEKA* Shell was measured during the *ESRa* project in August 2011 ([chapter 4.1](#)). The dimensions of the configuration were 4 m x 4 m x 9 m and the weight was about 39.8 t. The system provided an overall broadband noise reduction by 6-8 dB (SEL) ([Figure 24](#)) (WILKE et al. 2012). However, in order to interpret the low noise reduction measured in the framework of *ESRa*, the problems encountered during the project have to be considered (see [chapter 4.1](#)).

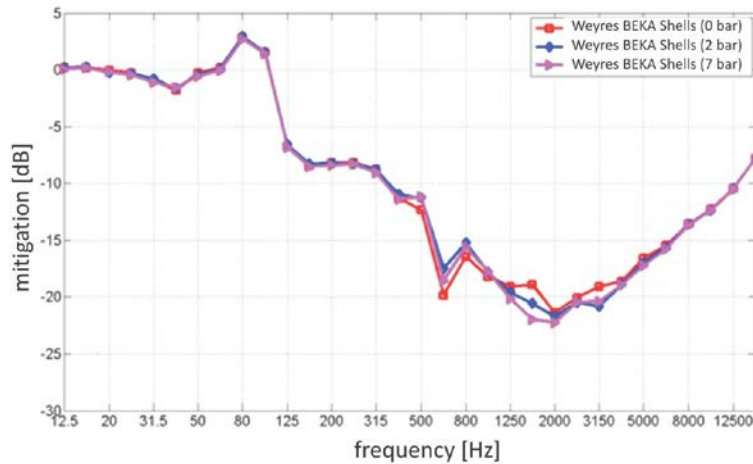

Figure 24: Difference spectrum (reduction of sound transmission) of the *BEKA Shell* measured in the *ESRa* project with and without inner bubble curtain (measurement distance 375 m) (source: WILKE et al. 2012, modified)

4.3.4 Valuation of Isolation casings

4.3.4.1 Noise Mitigation

Simple isolation casings do not act as effective noise mitigation methods because they achieve only little noise reduction. An important feature leading to a greater attenuation is the inclusion of air into additional layers. In various experiments, isolation casings have shown frequency-dependent noise reduction which varied strongly (Figure 19 to Figure 21) depending on the specific design of the protective shield (chapter 4.3.3). However, the overall noise reduction was similar to that of a bubble curtain or even better. Additional air-filled layers (bubble foil, installation foam, air bubbles) reduced the noise level by as much as 20 dB (ELMER et al. 2007a, CALTRANS 2007), thereby demonstrating a very large potential for noise reduction in experiments.

Damping of the frequency range with highest sound emissions can be optimised by choosing the appropriate dimension of the isolation casing. Noise reduction in the frequency range between 100 and 500 Hz would achieve the greatest effect with regard to the overall broadband sum value. The frequency range in which sound mitigation has its optimum may be influenced by choosing the appropriate distance between outer and inner steel wall (depending on wave length) (WILKE et al 2012) and maybe also by adapting the distance between pile and isolation casing. Different combinations of transitions between sound absorbent and non-absorbent materials of varying impedance (water-steel-air) may be used, but still more methodical investigations of a multitude of variations are required.

IHC Noise Mitigation system

By combining various physical principles of noise reduction (shielding/reflection, absorption, scattering) (see chapter 4.3.1) the *IHC NMS* achieved a considerable noise reduction that exceeded that of a bubble curtain. During the construction of the OWF *Riffgat* (chapter 4.3.3.1) no measurements of pile driving noise without mitigation system were performed, therefore no *in situ* reference value exists. Only the value predicted beforehand is available to estimate the noise emission without mitigation system. For a 5.7 m pile at 750 m distance a level of 180 dB (SEL) was predicted. Measurements at pile *R14* with the *IHC NMS* revealed an average level of 163 dB (SEL) or 187 dB (peak). This corresponds to a noise reduction provided by the *IHC NMS* in the order of 17 dB. It must be taken into account that the prediction was given with an uncertainty of 5 dB and consequently the same uncertainty has to be applied to the noise reduction value (GERKE & BELLMANN 2012). Therefore, no reliable conclusion on the noise reduction achieved can be drawn based on the available data.

BEKA-Shells

By combining several principles of noise reduction (shielding/reflection, double-wall covered with sound absorbing composite material, additional confined bubble curtain) ([chapter 4.3.2](#)), the *BEKA* shell has a high theoretical noise reduction potential that is assumed to exceed that of a bubble curtain significantly. The number of layers is even higher than in the *IHC NMS*, and since, moreover, a complete decoupling of outer and inner layer of the double-walls is supposed to be provided, this system may contain the highest noise reduction potential of all measures presented here - assuming that no sound leakages (e.g. at interfaces) exist. However, proof of the expected high reduction potential in an offshore field test is still lacking.

4.3.4.2 Development Status

In the development of isolation casings, the pilot stage has been successfully completed. Investigations accompanying model- and pilot tests demonstrated that a significant noise reduction could be achieved by acoustically decoupling the pile from the surrounding water by means of isolation casings and additional bubble curtains inside ([chapter 4.3.3.1](#) and [4.3.3.2](#)).

An advantage with regard to economic efficiency is the fact that both systems are reusable. During the construction process, the heavy weight of most isolation casings requires a special design of the jack-up-rig. As isolation casings are attached directly to the piling frame, they inevitably influence the construction time, regardless of whether the system is put over the pile from the top (*IHC NMS*) or laid around the pile (*BEKA Shells*). This likely has a negative effect on the costs. To compensate for this, concepts are needed that keep the handling time as short as possible. The investigative activities by *IHC Merwede* serve this purpose by aiming not only at further sound measurements but also at an improved practical application and the adaptation to varying locations and offshore construction situations.

IHC Noise Mitigation System

Several pilot tests which were accompanied by sound measurements have been successfully completed with various pile diameters at different water depths. After the test at Ijmuiden, the application at the OWF *Riffgat* is another full-scale test which has moreover been performed in the framework of the installation of a commercial offshore wind farm. The results achieved there are of special interest as the noise mitigation system and the monopile applied were the largest measured so far and the *IHC NMS* was further optimised compared to the first tests. Though the 160 dB threshold level has been exceeded by about 3 dB, the mitigation system achieved a good noise reduction by about 17 dB (SEL) compared to the predicted value without mitigation system (GERKE & BELLMANN 2012). By optimising the acoustically important properties of the system (extension of the distance between pile and isolation casing and the air-filled interspace between the walls as well as integration of axial and radial vibration dampers) (GERKE & BELLMANN 2012), the noise reduction compared to the prediction was increased from about 11 dB (system applied during the *ESRa* project) to about 17 dB (GERKE & BELLMANN 2012). It can be concluded that the system is suitable to achieve a considerable noise reduction during pile driving of large monopiles.

By the successful application of the *IHC NMS*, its robustness and suitability for the application under offshore conditions together with manageability, flexibility with respect to construction logistics as well as its safety has been demonstrated. Overall *IHC NMS* can be considered proven technology, but so far this is limited to water depths of up to 23 m, the prevailing depth at the OWF *Riffgat*. With respect to the noise threshold defined by the German approving authority BSH a further limitation is currently given by the pile diameter. However, it is assumed that the noise reduction achieved at the OWF *Riffgat* would have been sufficient to meet the 160 dB threshold level for smaller pile diameters or other soil conditions.

BEKA Shells

The development of the *BEKA Shells* is at the pilot stage. In addition to restrictions resulting from the geology and the specific situation of the test pile ([chapter 4.1](#)), which resulted in a disappointing noise reduction, the significance of the tests was further restricted by the position in relatively sheltered and shallow water. A prerequisite is that a prototype is successfully applied under offshore conditions thereby demonstrating the system's availability for use and its manageability and a satisfying noise reduction. Some components of the BEKA Shell from in-air noise mitigation applications are typically used in terrestrial projects and are market-available. This applies e.g. to industrial vibration dampers for acoustic decoupling. The use of market-available components and the design of several components with different dimensions to adapt the system to various water depths and pile diameters are important steps to make the method economically effective. In order to guarantee a complete enclosure of the entire sound emitting structure, the *BEKA shell*'s applicability is so far restricted to monopiles or tripiles. To be applied with jackets or tripods, the installation process has to be adapted. By applying the pre-piling procedure it is, however, possible though to attach and grout frame constructions such as jackets of tripods.

4.4 Cofferdams

Similar to isolation casings, cofferdams are rigid steel tubes surrounding the pile from seabed to surface. In contrast to them, the interspace between pile and cofferdam is completely dewatered. Hence pile driving takes place in air and not in water thus decoupling the propagation of sound from the body of water. The cofferdam can be applied at water depths of up to 45 m at least (KURT E. THOMSEN, pers. comm.). The application is limited by the capabilities of the rubber seal at the bottom. In shallow water, sheet pile walls are often used as cofferdams (CALTRANS 2009), but this is not feasible in deeper water where sealed steel piles are used to avoid the hydraulic breaking of the ground, a heave caused by the high hydrostatic pressure.

4.4.1 Cofferdam

A technology developed for offshore wind farm applications by *Lo-Noise Aps* (Aarhus, Denmark) and *SeaReenergy Offshore* (Hamburg, Germany) is a cofferdam placed on the seabed into which the pile is inserted and centred with the help of wedges. The annular gap between pile and cofferdam is sealed at the lower end by a tight rubber seal, thereby preventing water from intruding. Three pump heads at the bottom ensure the complete dewatering of the cofferdam. This dewatering process leads to an acoustic decoupling of noise generated by pile driving within the cofferdam (THOMSEN 2012). The concept additionally includes the construction of a telescopic system which allows for the adaptation to varying water depths. For the installation process the development of a tubular cofferdam system, in which the pile is already inserted on the jack-up barge prior to erecting the pile together with the surrounding cofferdam, is being pursued further.

Cofferdams can also be applied to jacket foundations. Specific adaptations may be required at the transition to the template (for a pre-piling procedure) or at the pile sleeve (for a post piling procedure) in order to prevent sound leakages. It has to be considered that noise mitigation during a post-piling procedure may be less effective than during pre-piling because sound is transmitted by the entire oscillating structure. The deployment of cofferdams for noise mitigation is scheduled for the construction of the jackets for the converter platforms *BorWin beta* (2013), *HelWin alpha* (2013) and *SylWin alpha* (2014) (see also [Figure 25](#)).



Figure 25: Cofferdam by *Lo-Noise/SeaReenergy* during the test at Aarhus Bight (source: THOMSEN 2012)

4.4.2 Pile-in-Pipe Piling

A particular case of a cofferdam is the principle of **Pile-in-Pipe Piling** of a jacket foundation (FRÜHLING et al. 2011). In this case, four cofferdams (protective pipes) are the four legs of the foundation (“quadjack”, [Figure 26](#)). The cofferdams are not reusable as they will be grouted to the foundation piles and as such they are part of the foundation and serve as isolation casings.

The piles reach beyond sea level, hence in contrast to pile driving of a conventional jacket foundation piling occurs only above sea level and the cofferdam acts as a noise barrier throughout the whole water column ([Figure 26](#)) (FRÜHLING et al. 2011). The pile extension required to enable pile driving is achieved by means of an adapter, a so called follower. Thus, an acoustic decoupling is enabled by the construction itself. Complete dewatering of the annular gap and avoidance of sound leakages (e.g. by wedges) is critical for the system’s effectiveness. Appropriate technical solutions to dewater and seal the 5-10 cm annular gap are currently under development. Pneumatic seals will be used to seal the annular gap against penetrating sea water at the bottom and against rain and splash water at the top. Crux grout seals and hose seals together with the envisaged guide shims guide the pile during pile driving. Using overpressure, water will be pressed out through pipes flanged to the outside of the cofferdams. Approximately 1 bar is needed at a water depth of 8.5 m, and 4-5 bar at a water depth of 40 m.



Pile-in-Pipe Piling

assumptions:

- overall height: 64 m
- pile length: 65.0 m
- pile diameter 1.60 m
- pile wall thickness: 0.03-0.05 m
- pile sleeve length: 60.0 m
- outer diameters of pile sleeves: 1.70 m, 1.80 m, 1.90 m, 2.0 m
- wall thickness of pile sleeve: 0.025 m
- material: S 355 NL
- water depth: 40 m
- hydraulic hammer: MHU 500 t

Figure 26: Concept of a quadjack foundation with Pile-in-Pipe Piling for the application with an offshore wind turbine (source: OVERDICK GmbH & Co. KG, Hamburg, modified)

4.4.3 Experience with Cofferdams

A pilot test with a dewatered cofferdam by *Lo-Noise* und *SeaReEnergy Offshore* with an inner diameter of 2.5 m (pile length: 36 m, pile diameter: 2.13 m, hammer: *MENCK MHU 800*, water depth: 14-15 m) was performed in Aarhus Bight in December 2011 by *Siemens* and *TenneT*. The pile was centred using pneumatic salvage pillows. Piling up to a penetration depth of 11 m was performed with the cofferdam applied. Afterwards the cofferdam was removed to get a reference measurement without noise mitigation (THOMSEN 2012). An average broadband noise reduction by 23 dB (SEL) and 19 dB (peak) was achieved with 100% impact energy (175 dB (SEL) without noise mitigation compared to 152 dB (SEL) with cofferdam, both measured at 750 m). Best results were achieved for frequencies between 100 and 500 Hz (THOMSEN 2012).

A second offshore test at the OWF *Anholt* located in the Kattegat (pile diameter: 5.9 m, cofferdam diameter: 6.3 m) was not successful due to problems with centring wedges: the pile was slightly off the centre and the seal flipped upwards creating a leak. Due to this the annular gap was immediately filled with water which prevented effective noise mitigation (THOMSEN 2012).

4.4.4 Valuation of Cofferdams

4.4.4.1 Noise Mitigation

A good noise mitigation of a cofferdam can be expected based on the large impedance mismatch between air and steel (APPLIED PHYSICAL SCIENCES 2010). The noise reduction of 23 dB (SEL) measured in a pilot test is in line with results of various bridge construction projects in shallow waters (up to 15 m) in the US (noise reduction by about 25 dB; CALTRANS 2007) and with expectations from models¹² (about 20 dB; APPLIED PHYSICAL SCIENCES 2010). When these reduction values are corroborated by measurements in further tests, the mitigation system could be suitable to comply with the 160 dB threshold level even for piling larger monopiles.

Models of noise mitigation during pile-in-pipe piling with a quadjack under complete dewatering calculated reduction levels of up to 43 dB (FRÜHLING et al. 2012). The width of the annular gap of 5-20 cm between foundation pile and supporting tube (the cofferdam) does not have a significant impact on the overall noise reduction level. The guiding pieces however may lead to the sound leakages which reduce the cofferdam's effectiveness considerably. This effect could be minimised by the application of rubber inserts for acoustic decoupling, resulting in a noise reduction for this particular case (dewatered, guiding pieces decoupled) of 27 dB (FRÜHLING et al 2011). A foam coating of the supporting pile might offer additional noise reduction potential.

No sound measurements are available for the dewatering process by pumps in cofferdams or the injection of pressurised air. However, such noise emissions are continuous rather than impulsive and it may be assumed that the sound levels are below the 160 dB threshold level and below the levels of impulsive pile driving even when reduced by mitigation methods.

For frame constructions like quadjacks soil preparation may be required as well as a sour protection (FRÜHLING et al. 2012). Possible noise emissions during these processes are not taken into account in this study.

4.4.4.2 State of Development

In the US, cofferdams have been applied in various commercial projects and thus can be considered proven technology for the use in the case of sheet pile walls. A full-scale test (pilot stage) has been completed with an isolation casing pipe (CALTRANS 2007). In contrast, in the much deeper waters in the German EEZ the application of cofferdams during the construction of offshore wind farms is very innovative and further tests are needed.

The complete dewatering of the cofferdam when used for large monopiles is not a simple task. Previously, cofferdams were exclusively used in shallow waters (e.g. bridge construction in US at water depths <15 m; pilot test at Aarhus Bight at 14 m water depth). For the telescopic cofferdam which is intended for water depths of up to 45 m at least (THOMSEN 2012) and also for pile-in-pipe-piling, a rubber seal at the bottom between cofferdam and pile prevents further water inflow despite the prevailing high hydrostatic pressure. Small amounts of water can easily be pumped out. Therefore, the annular gap must be small and sealed at the bottom.

¹² Input data of the model were results from the Cape Wind project in Alaska (water depth 15 m, monopiles of 5.5 m diameter and 42 m length, wall thickness 50 mm, embedment depth 13 or 26 m) and representative data from European studies at water depths of 30 m (pile diameter 7.5 m, wall thickness 75 mm, pile length 65 m, embedment depth 35 m).

Cofferdam

The concept of the cofferdam to be applied under offshore conditions ([chapter. 4.4](#)) is currently in the pilot stage. In the near future commercial projects are planned at three converter platforms. A first test with a small monopile (2.13 m) was successfully completed with regard to noise mitigation and handling, thereby demonstrating its ability to effectively reduce noise. The system applied was, however not yet telescopic. During the second full-scale test with a large monopile (\varnothing 5.9 m) technical problems were encountered: pile and cofferdam were not assembled concentrically and thus a seal flipped upwards due to the high hydrostatic pressure. This incident shows that the design of pile and cofferdam must be closely matched and the width of the annular gap minimised. A further prototype is currently under construction and is scheduled for a third offshore test with a 5.5 m monopile in December 2012 (KURT E. THOMSEN, pers. comm.). Once it is successfully completed this test will demonstrate the suitability with regard to handling also for large monopiles.

It is an advantage of the free-standing cofferdam with regard to economic efficiency that material is saved as compared to the version that is part of the foundation (pile-in-pipe piling) because the system is reusable. Another economic advantage compared to other noise mitigation systems is that cofferdams work without compressors continuously producing bubble curtains. Nevertheless, different foundation types require different adaptations of the cofferdam. The offshore test at the OWF *Anholt* (6.3 m cofferdam for a 5.9 m pile) has demonstrated that it is unfavourable when the annular gap is too large because this makes centring of the pile difficult. Sealing of the cofferdam at the bottom against water intrusion may fail in such a case (THOMSEN 2012).

A test is required to verify the applicability of the telescopic system and the innovative concept of the erection mechanism. The use as erection mechanism and “guiding frame” is also economically beneficial as the installation of the noise mitigation system needs only little additional work that could potentially interfere with the construction process and work schedule (e.g. pumping of water). However, the system requires a specifically designed installation platform, hence not every available jack-up barge is readily suitable for the installation of a cofferdam.

Pile-in-Pipe Piling

Pile-in-pipe piling is presently in a validated conceptual stage. As this technique is a variation of a common and proven foundation technology, the components required are to a great extent available on the market. Design work has been performed for a jacket foundation with four corner piles (quad-jack) resulting in the finding that such a piled steel construction can be safely anchored in the North Sea at water depths of 30 m and a high noise reduction is to be expected (FRÜHLING et al. 2011). Sound measurements at the *Lo-Noise Aps* cofferdam ([chapter 4.4.3](#)) revealed a high noise reduction potential. A corresponding design with an appropriate bearing capacity can be developed similarly to that of a conventional jacket foundation.

The installation of a quadjack with pile-in-pipe piling is similar to the installation of a conventional jacket foundation, the only difference being that the protective pipe has to be dewatered before piling, hence there is not much reason to doubt the functionality of the principle. Some of the components (crux-seal, tube seals) are already available on the market. During the installation process no external noise mitigation system needs to be applied, hence the scheduling risk is reduced when compared to a conventional jacket foundation with additional noise mitigation systems. The noise mitigation system therefore does not pose a risk in calculating the costs. However, a considerable disadvantage when compared to conventional jackets is that more material is needed, hence the costs rise. At water depths of 40 m about 300-400 t of additional steel are required (FRÜHLING et al. 2011, ECKEHARD OVERDICK, Overdick GmbH & Co. KG, Hamburg, pers. comm.).

4.5 Hydro Sound Dampers (HSD) / “Encapsulated Bubbles”

An innovative noise mitigation method developed by the company *OffNoise Solutions GmbH* and the *Technical University of Braunschweig* is a system of **Hydro Sound Dampers (HSD)**, small gas filled elastic balloons and robust PE-foam elements fixed to nets or frames placed around the pile. The underlying principle is identical to that of a bubble curtain with the exception that the frequencies at which the maximum noise reduction is provided are adjustable by variations in the balloon size. The main principle is based on the excitation with the resonant frequencies causing scattering and absorption. Also, reflection occurs at the transition from water to air, similar to an air bubble curtain (LEE et al. 2011, ELMER et al. 2012). The determining factor for the resonance effect is the oscillation behaviour and thus material characteristics and shell thickness (LEE et al. 2010, 2012). High energy absorption is reached by means of material damping. In the specific case of PE foam elements (which act like tuned impact absorbers using special dissipative material) this is the only effect acting in a broadband part of the spectrum (ELMER et al. 2012).



Figure 27: HSD-Platform above the test pile (source: WILKE et al. 2012, photo: Patrice Kunte)

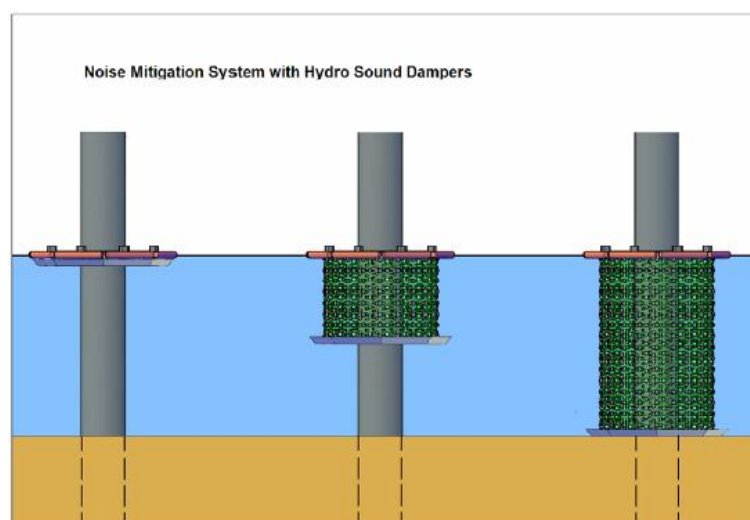

Figure 28: Schematic diagram of the HSD single-net system tested in the *ESRa* project (retracted, half- und fully extended) (source: TU Braunschweig/Dr. Elmer in: WILKE et al. 2012)

The balloons are attached to rigid frames or nets completely enclosing the pile (Figure 28, Figure 30). The *HSD* system is very variable with respect to assembly design: From staggered grids to ground covering nets or rigid framework constructions, uncoiled from winches, fixed to piling frames or free-floating, everything is conceivable in order to find the best solution for a given foundation concept.

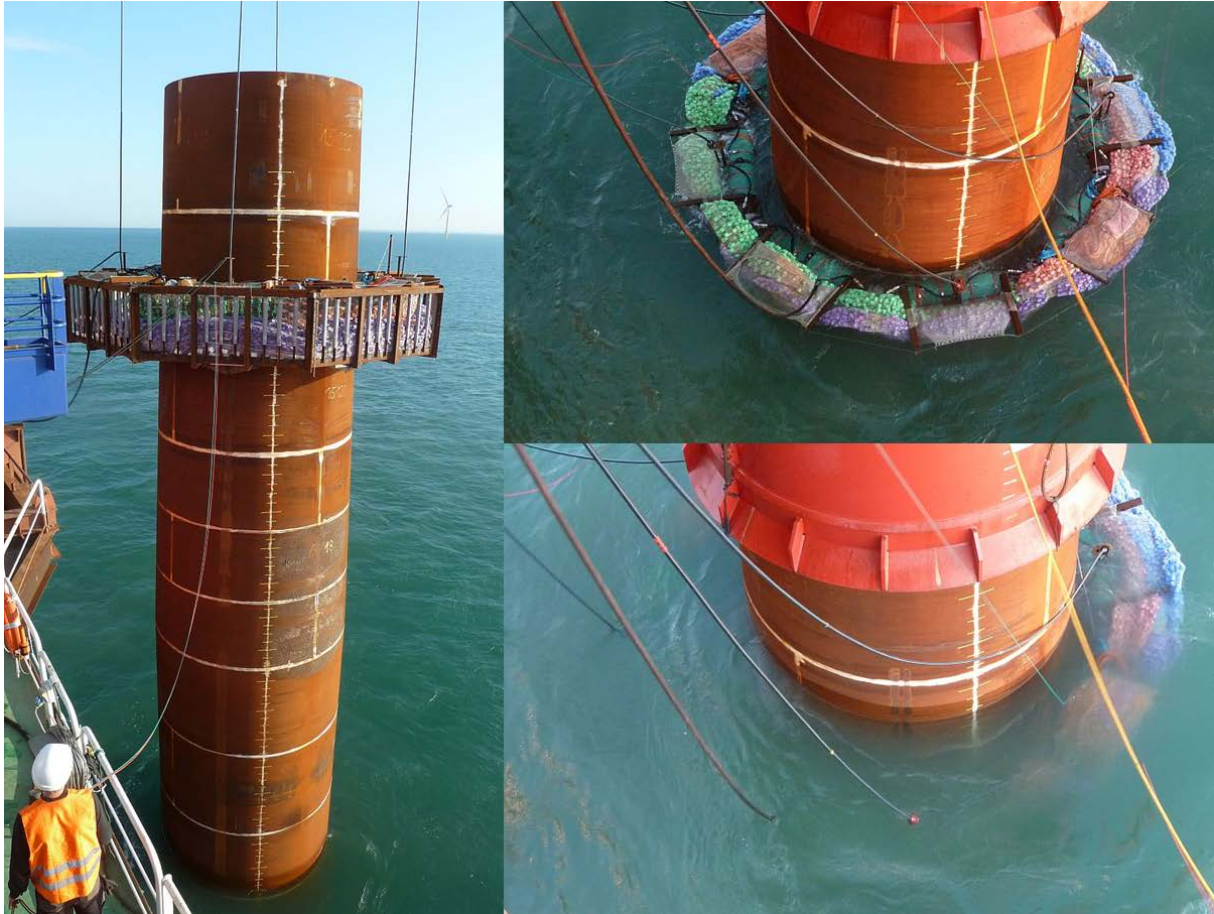

Figure 29: Test of the *HSD* system in a practical application at a monopile in the OWF *London Array* (source: ELMER et al. 2012)

A system using the identical principle of “**encapsulated bubbles**” is currently under development in the US (LEE et al. 2010, 2011, 2012). The idea is to achieve a reduction of the low frequency components of pile driving noise by means of balloons of diameters ranging from 6-12 cm. Balloons of this size have a predicted resonant frequency (“eigenfrequency”) is in the range 175-50 Hz. With increasing size of the balloons the maximum noise reduction is shifted to lower frequencies (LEE et al. 2012).

4.5.1 Experience with *Hydro Sound Dampers* / “**Encapsulated Bubbles**”

Tests with *HSD* were conducted in the large wave flume of the Coastal Research Centre (FZK) in Hannover. These *HSD* balloons had a diameter of 6 cm (Figure 30) and were designed to reduce noise at frequencies around 100 to 300 Hz. *HSD* used only a minor fraction (8 to 10 %) of the net area (ELMER et al. 2011). In laboratory experiments using a sound source of gradually changing frequencies (“sweeps”) a broadband reduction by 20-22 dB (SEL) and 19 dB (peak) was achieved (ELMER 2010). The controlled resonance behaviour allowed for a high noise reduction by 20 to 30 dB (SEL) in the frequency range of 200 to 300 Hz (ELMER et al. 2011).

In the *ESRa* project various types of *HSD* elements attached to three layers of nets (mesh size 2 cm) arranged as concentric rings with weights compensating for floatation were tested in the Baltic Sea. The inner net ring (\varnothing 2.9 m) was deployed with two layers of air-filled *HSD* balloons. The middle net ring (\varnothing 4.8 m) was equipped with robust *HSD* foam elements, whereas the outer ring (\varnothing 6.6 m) had only one layer of *HSD* balloons. *HSD* elements were attached in a 20 x 20 cm grid. The whole system weighed 10 t (Figure 27, Figure 28) (WILKE et al. 2012). All deployed *HSD* elements were tuned to an eigenfrequency of 120 Hz in order to mitigate the noise between 100 and 500 Hz. This frequency range dominates the broadband level of the radiated piling noise.



Figure 30: Scattering and absorption tests with *HSD* balloons in a wave flume (left) und preparations for practical application of an *HSD* net (\varnothing 9m, height 28 m, weight of the complete system 17 t) at the OWF London Array (right) (sources: ELMER et al. 2011, 2012)

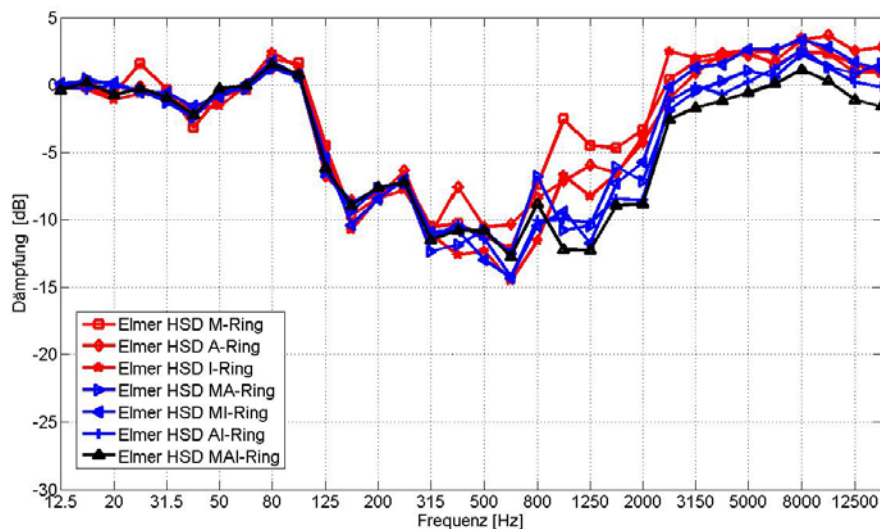

Figure 31: Difference spectra measured during the *ESRa* project of *HSD* (measuring distance: 375 m), all seven variations of three net layers (I – inner layer; M – medium layer; A – outer layer) (source: WILKE et al. 2012)

In the *ESRa*-project a broadband noise reduction by 4-14 dB (SEL) was measured at distances of 375 m and 750 m (Figure 31) (WILKE et al. 2012). However, in order to interpret the low noise reduction measured in the framework of *ESRa*, the problems encountered during the project have to be considered (see chapter 4.1). Additional near-field measurements of sound pressure (distance to pile: 6 m, 4 m above sea ground) demonstrated distinct differences in the sound pressure signal induced by the impact, with and without *HSD* (Figure 32). The impact energy is almost completely attenuated by means of the *HSD*. These near-field measurements were supposed to adjust for the site-specific unusual influence of the sediment and the interaction between sediment and encrusted pile (chapter 4.1 and Figure 32) (ELMER et al. 2012). In the near field, no bottom reflection or local indirect

influence interferes with the sound measurement. This enables a measurement of the system-specific noise reduction (WILKE et al. 2012). However, this aspect is important in theory but not in the practical application, which has to comply with a legal noise limit.

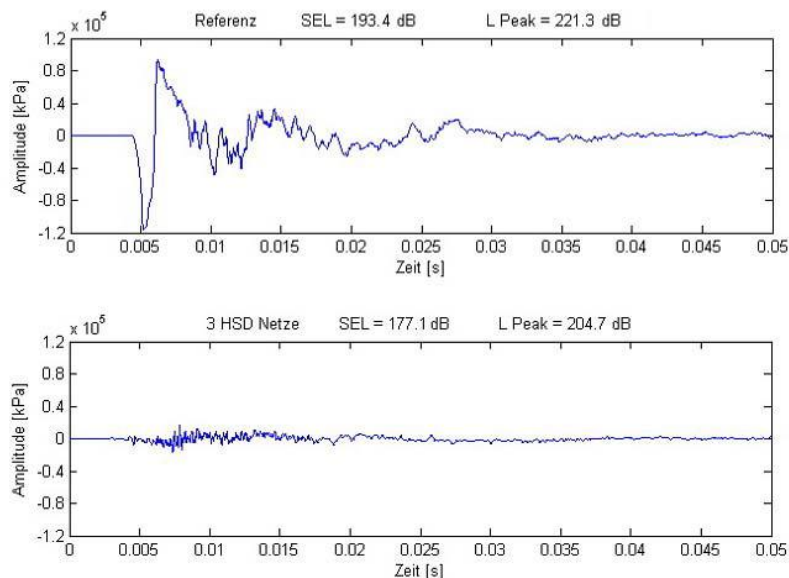

Figure 32: Sound pressure time signature measured at a distance of 6 m from the pile (above) without noise mitigation, and (below) with *HSD* (source: WILKE et al. 2012)

Further, *HSD* were tested during the installation of the British OWF **London Array** (Figure 29). Exclusively PE foam elements were used. For this test, the configuration of the middle *ESRa* net (see above) was supplemented by smaller as well as larger elements. These tests mainly aimed at demonstrating the functionality of the system, the work routine and the safety in handling under offshore conditions. Currently no final results of the sound measurements carried out at depths between 14 and 28 m are available (ELMER et al. 2012). These are scheduled for publication in the first quarter of 2013.

“Encapsulated Bubbles”: A proof-of-concept experiment of a system using identical principles was performed in Lake Travis (a fresh water lake in central Texas, US) using a mechanically-vibrated barge as a noise source. These oscillations were similar to those generated during certain seismic surveys. The peak frequency of the radiated noise was governed by the rotational speed of the engine and was approximately 70 Hz although harmonics and broadband chaotic noise were also present in the measured spectra. A screen of 60 encapsulated bubbles¹³ tuned to an eigenfrequency of 50 Hz shielded the sound source from the measuring hydrophone (LEE et al. 2012). They provided up to 18 dB of noise reduction near the bubble resonance frequency and thus a higher noise reduction could be achieved compared to a bubble curtain measured in comparison. The size of encapsulated bubbles was chosen so that the screen provided the most noise reduction at frequencies near the peak frequencies emitted by the noise source (LEE et al. 2012).

In a second experiment, an encapsulated bubble curtain of nearly 900 PU balls spaced 125 cm by 27 cm was used to partially shield a receiving area in direct line from underwater pile driving noise at a distance of 2.5 km. Eight steel piles with a diameter of 1.2 m were driven. At a distance of 112 m without noise mitigation an average peak-to-peak¹⁴ level of 185 dB was measured. At 2.5 km the

¹³ Their operating principle is identical to that of the *HSDs* by *OffNoise-Solutions GmbH*

¹⁴ Corresponding to a peak level of approximately 179 dB

measured level was 150 dB¹⁵. The curtain of encapsulated bubbles provided a spectral noise reduction up to 14 dB in the 100 Hz–300 Hz frequency band coincident with the peak frequencies generated by the pile driving events (LEE et al. 2012).

4.5.2 Valuation of *Hydro Sound Dampers*/"Encapsulated Bubbles"

4.5.2.1 Noise Mitigation

The *HSD* system is designed to compensate for two disadvantages of a bubble curtain with freely rising air bubbles. On the one hand, the system must cope with currents in order to maintain a closed shield around the foundation ([chapter 4.1](#)). On the other hand, the resonance frequency of a bubble is inversely proportional to its diameter which behaves chaotically when rising in the water column. In *HSD*, this frequency-dependent effect can be actively used for an optimum design in order to reduce noise at frequencies which contribute the most energy (typically around 100 to 300 Hz in piling) or to allow for the noise reduction at specific frequencies in relation to the susceptibilities of affected animals. The maximum reduction provided by a bubble curtain deployed during construction of the *FINO 3* research platform in the North Sea was found at frequency bands between 1 and 2 kHz (-35 dB) whereas noise reduction at frequency bands below 300 Hz was less than 10 dB (BETKE 2008). Thus, a major advantage compared to the bubble curtain is that the size of balloons or PE foam elements defines the resonance frequency which enables the attenuation of desired frequency bands. Next to size, other variables enabling a control over the effect of *HSD* are number and distribution of *HSD*, gas pressure inside the *HSD* and material stiffness (or type such as balloon or foam). The air volume in the water column (as a function of size and number of *HSD*) determines the magnitude of the noise reduction (LEE et al. 2011).

The sound reduction by ***HSD elements*** in a large wave flume was much larger than that of bubble curtains applied in offshore waters so far ([chapter 4.5.1](#)) (ELMER et al. 2011). A defined maximum reduction within the frequency range of 100 to 300 Hz was reached by tuning the *HSD* elements to 120 Hz. It is unclear if these results can be transferred to piling noise under offshore conditions.

The analysis of the ***ESRa tests*** shows that by means of *HSD* the sound energy of the piling impact can be substantially reduced ([Figure 32](#)). The results of these near-field measurements can be transferred as the system-specific noise mitigation to other situations (WILKE et al. 2012). In discrete third-octave bands (125, 300 und 500 Hz) the *HSD* elements (balloons as well as PE foam elements) in three nets provided a spectral reduction of piling noise by up to 23 dB. Their effect results almost exclusively from the damping process; resonance frequencies do not contribute to the overall noise reduction.

Preliminary results from near-field measurements in the ***London Array*** test show that supplementary foam elements of various sizes improved the noise reduction compared to the *ESRa* results at lower frequencies (up to 20 Hz) and at higher frequencies (up to 3 kHz) (KARL-HEINZ ELMER, *OffNoise Solutions GmbH*, Neustadt, pers. comm.). This is an important step to improve the predictability of noise reduction by certain configurations.

Also, the ***American tests*** demonstrate that „**encapsulated bubbles**“ may effectively reduce underwater noise. The reason for the comparatively low spectral noise reduction of the tethered bubbles applied at pile driving in Lake Travis is the large distance of the bubbles from the sound source which allowed indirect radiation of surface- or bottom-reflected sound to bypass the curtain (LEE et al. 2012). Further, the spacing of encapsulated bubbles was larger than in the laboratory tests of *HSD* elements (see above).

¹⁵ Corresponding to a peak level of approximately 144 dB

Due to the multitude of test configurations and the generally very high variability of the *HSD* method to date, no concluding statement about the achievable broad band noise reduction can be made. Sound measurements so far indicate that the targeted configuration options allow for a high noise reduction.

4.5.2.2 Development Status

Experience gained with ***HSD* elements** under offshore conditions is meanwhile available from the *ESRa* project and from the *OWF London Array* (sound measurements not published yet). The lowering of *HSD* nets from the piling frame (Figure 29) was carried out without problems, and also the handling safety tests went according to plans (KARL-HEINZ ELMER, *OffNoise Solutions GmbH*, Neustadt, pers. comm.). With the completion of these tests the pilot stage is reached for the piling of mono-piles or pre-piled frame constructions. Currently, there are plans for the further development of the attachment and deployment method of the *HSD* system, the optimisation of the operations layout and adaptations for the installation of post-piled jacket foundations (KARL-HEINZ ELMER, *OffNoise Solutions GmbH*, Neustadt, pers. comm.).

After analysing the pilot tests in the Baltic Sea (water depth: 9 m, pile diameter: 2.2 m) and those under tidal conditions in the North Sea (*OWF London Array*, water depth: 14-28 m, pile diameter: 4.7 m) the system appears robust for offshore conditions and capable of being integrated into the operations layout (BRUNS et al. 2012). In the first full-scale test of *HSD* elements under offshore conditions at the *OWF London Array* the installation of the noise mitigation system took only two hours longer than piling without noise mitigation (BRUNS et al. 2012). The experience collected so far can result in a further development of the concept which further shortens the handling time.

With respect to handling and cost-efficiency *HSD* nets provide advantages. Many of the components needed for the fabrication of *HSD* nets are already available on the market. The open structure due to the low proportion of *HSD* elements attached to nets within the water column enables currents to flow through the mitigation system which is not the case in rigid systems shielding the pile such as isolation casings (chapter 4.3) of cofferdams (chapter 4.4) (ELMER 2010). Floating debris is not considered a problem by the developer.

An important advantage compared to bubble curtains is that no compressors are needed to provide the noise reduction making the system more cost-efficient (LEE et al. 2011). Thus, the additional handling time of the *HSD* nets needed within the operations layout of the complete installation is a critical parameter. In waters with strong tidal currents the attachment method must be robust enough to withstand the water flow and flexible enough to enable flow-through. The developer already introduced various attachment methods adapted to a number of environmental conditions. Since only few of them have already been tested their practicability remains to be shown. As all systems attached close to the pile or foundation structure the deployment time has to be considered in order to guarantee a smooth and organised course of construction without delays. The handling time of the *HSD* system is assumed to be low. Due to the low weight and the flow-through there is no need for complex and costly adaptations in construction design. The weight of only 17 t (in the *OWF London Array*) requires only minor adaptations on the installation platform. A small lifting device and a gripper are sufficient for handling, which anticipates short installation times (KARL-HEINZ ELMER, *OffNoise Solutions GmbH*, Neustadt, pers. comm.).

The next steps will be the further optimisation of *HSD* elements for various frequency bands as well as the simultaneous use of multiple net layers, a larger number and various types of *HSD* elements in a further full-scale test in the *OWF Dan Tysk* (2013) (K.-H. ELMER, *OffNoise Solutions GmbH*, Neustadt pers. comm.).

4.6 Acoustic Improvement of the Piling Process

Prolongation of the Pulse Duration

A pile strike generates a shock wave within the pile. The velocity of its lateral deflection (lateral extension of the pile) directly influences the sound transmission into the water body. The maximum sound pressure emitted depends, not least, on the geometrical setup, e.g. the relation of the shock wave's wave length to pile length/water depth. Only about 1-2% of the overall energy is converted to sound energy (ELMER et al. 2007a).

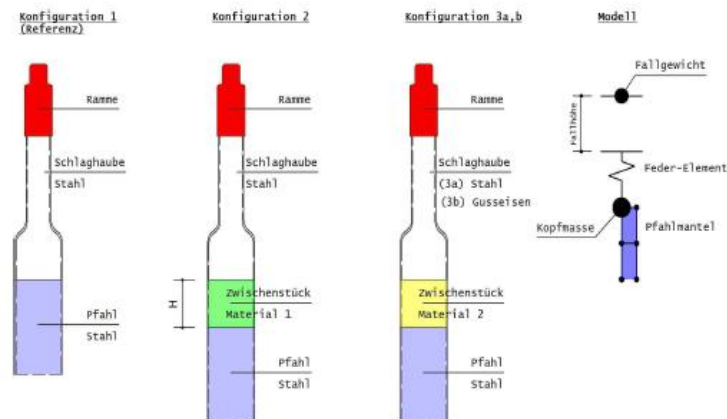

Figure 33: Piling cushions between hammer and pile (source: NEUBER & UHL 2012)



Figure 34: Piling cushions tested in the experiments by the Washington State Department of Transportation before being used (left), and fractured and compressed plywood piling cushion after being used (right) (source: LAUGHLIN 2006)

The pulse duration of a pile strike of about 4 ms is very short. Numerical investigations revealed that prolonging the pulse duration reduces the corresponding sound emission (ELMER et al. 2007a, b). As the impact energy is distributed over a longer time period, the maximum impact force and thus the amplitude of the lateral extension is reduced. At the same time the frequency spectrum emitted is shifted to lower frequencies because the oscillation period is prolonged. Hence, the reduced propagation velocity of the lateral extension directly decreases the sound emission. As the rise time of a pulse is an important aspect of the inherent injury potential of an acoustic pulse to marine organisms (the shorter the rise time, the higher the injury potential), an extension of the pulse duration reduces the risk of injury to marine organisms. In principle, an extension of pulse duration can be achieved by an elastic piling cushion between hammer and pile (ELMER et al. 2007a, b, NEUBER & UHL 2012) (Figure 33, Figure 34).

Piling cushions are blocks of material placed atop a pile during pile driving to minimise the noise immissions. Materials typically used for piling cushions include plywood, *Nylon*, and *Micarta* (*Micarta* is a homogeneous compound that uses a phenolic resin known as *Bakelite* to bind various fillers under pressure). Other materials may also be used, e.g. elastic steel cable (NEHLS et al. 2007, CALTRANS 2009). Piling cushions are often used primarily as a means of protecting the pile and the piling equipment.

Optimisation of Piling Components

The sound radiation from a driven pile may be directly altered by modifications of the pile's vibration characteristics. By optimising the composition of all input variables within the piling process, the acoustical best-case version may be chosen from all possible technical constellations. Components to be altered include hammer, anvil, impact energy, pile diameter and wall thickness (ULRICH STEINHAGEN, *MENCK GmbH*, Kaltenkirchen, pers. comm.).

A joint project by *MENCK* (Kaltenkirchen, Germany) and *CADFEM* (Grafing, Germany) developed a transient finite element simulation to predict the sound generation and radiation during pile driving. The numerical model included hammer, anvil, follower, pile, seabed and water as input parameters (STEINHAGEN & MOOS-RAINER 2011). As a result, the model predicts the sound transmission and propagation during pile driving operations in relation to the individual components. However, another possible field of application for the models is the optimisation of the variable components within the piling process in order to minimise the noise immissions.

A different numerical model to determine the basic components that affect the propagation of sound within the system of hammer, pile, seabed and water by means of the finite element method was developed during the research project "*Schall 3*" (NEUBER & UHL 2012). The effectiveness of prolonging the pulse duration ([chapter 4.6.2.1](#)) was calculated by means of this model.

4.6.1 Experience with Acoustic Improvements of the Piling Process

Prolongation of Pulse Duration

Modelling a pile of the *FINO 1* research platform (\varnothing about 1.5 m, length 36 m) revealed that doubling the pulse duration reduces the peak sum level by about 9 dB and the third octave sum levels by about 3.5 dB ([Figure 35](#)) (ELMER et al. 2007a).

Studies at the *FINO 2* platform (\varnothing 3.3 m) using a coiled steel cable as a piling cushion between hammer and pile revealed a prolongation of the pulse duration by a factor greater than 2. A noise reduction by up to 7 dB was achieved for the initial hammer strikes ([Figure 37](#)) (ELMER et al. 2007b).

The effectiveness of prolonging the pulse duration with respect to noise reduction was calculated by the numerical model developed during the project "*Schall 3*" (NEUBER & UHL 2012). The model demonstrated best results with layers of minimal stiffness ([Figure 33](#)). Important parameters are the dimension and material properties of the piling cushion. With the example of the *MENCK* test pile (Lübeck Bight, German Baltic Sea), a piling cushion of *Aramid* (configuration 3 in [Figure 33](#)) showed a noise mitigation of up to 5 dB (SEL) and 7 dB (peak). In the example of the *FINO 3* monopile a noise reduction by up to 11 dB (SEL) and 13 dB (peak) was calculated (NEUBER & UHL 2012).

Investigations on the effectiveness of piling cushions between pile and hammer were performed by the *Washington State Department of Transportation* in 2006 during construction works at Cape Disappointment with 12 inch piles (about 30 cm). In all experiments with piling cushions, the impulse duration was clearly prolonged. Plywood cushions prolonged the pulse duration to values of up to 38 ms whereas with *Micarta* values between 8 and 13 ms were achieved (LAUGHLIN 2006).

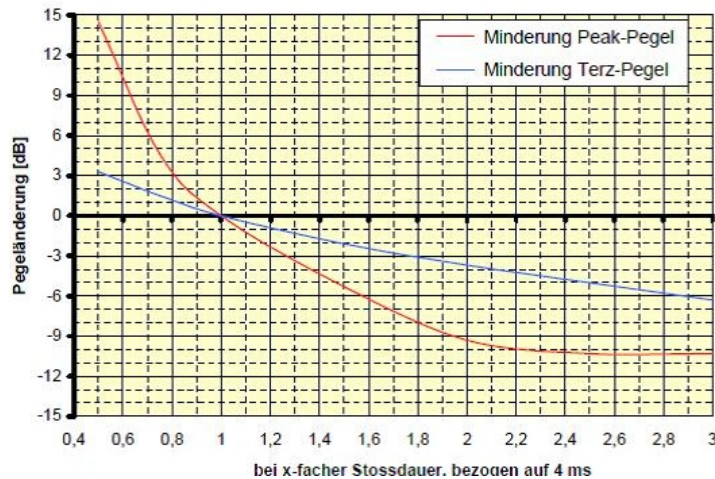

Figure 35: Numerical simulation of noise mitigation by prolonging the impulse duration, given as peak level (red line) and third octave sum level (blue line). X-axis: multiple of pulse duration with respect to the reference value of 4 ms (\varnothing about 1.5 m, length 36 m). Y-axis: sound level (dB) (source: ELMER et al. 2007a)

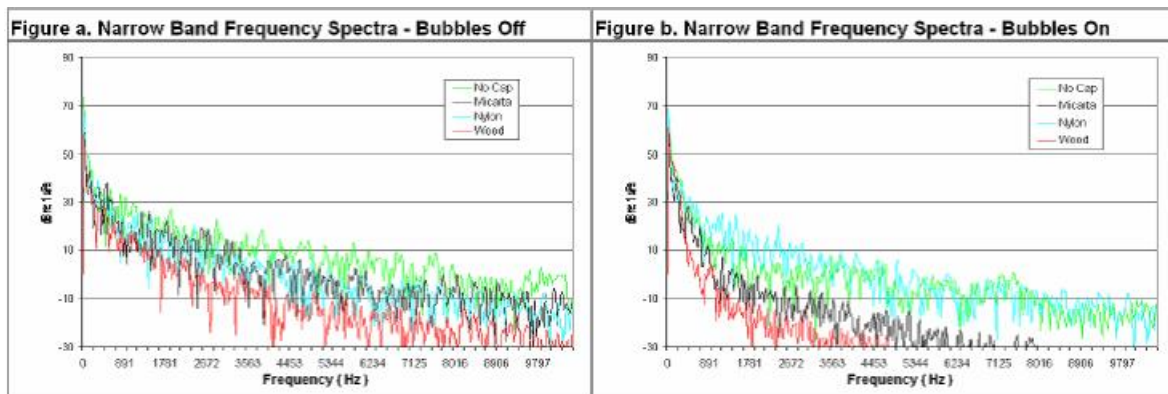

Figure 36: Spectral frequency analysis comparing *Micarta*, *Nylon*, and plywood piling cushions versus no cushions with additional bubble curtain on and off (source: LAUGHLIN 2006)

The noise reduction was dependent on the material of the piling cushion (Figure 36). Plywood piling cushions clearly had the greatest effect with a noise reduction ranging from 11 to 26 dB. At the same time, plywood had the longest impulse duration. With *Micarta* also a considerable noise reduction between 7 and 8 dB could be achieved, followed by *Nylon* with 4-5 dB reduction (LAUGHLIN 2006). The technical limitations of using plywood as a piling cushion are described in [chapter 4.6.2.2](#).

4.6.2 Valuation of Acoustic Improvements of the Piling Process

4.6.2.1 Noise Mitigation

Prolongation of Pulse Duration

The coiled steel cable as a piling cushion between hammer and pile at *FINO 2* increased the pulse duration and reduced the noise level. However, due to the progressive compression of the material, this effect decreased after only a few strikes and noise mitigation was no longer achieved (Figure 37) (ELMER et al. 2007b).

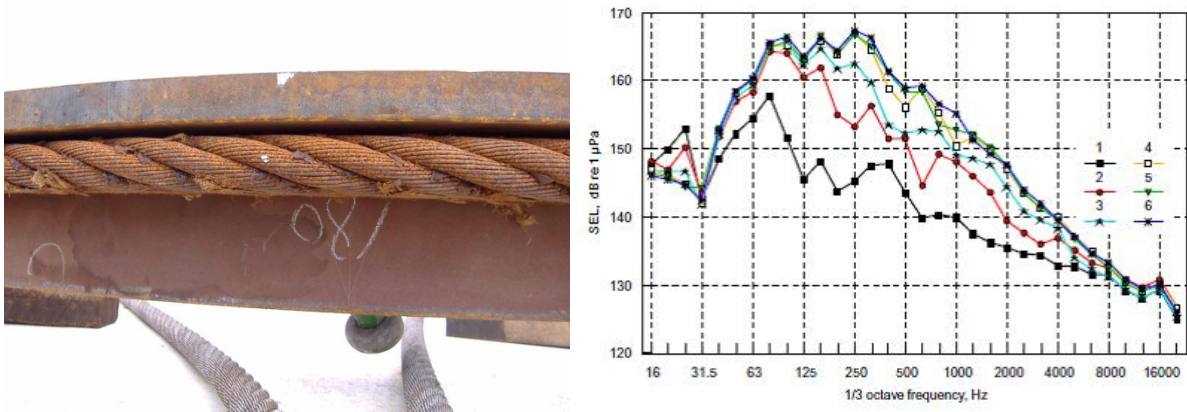

Figure 37: Coiled steel cable as piling cushion (left), and results of sound measurements for the first six strikes with this piling cushion (frequency-resolved SEL; measuring distance: 530 m) (source: ELMER et al. 2007b)

While piling cushions reduce the sound pressure level by prolonging the pulse duration, at the same time this prolongation is associated with a loss of force on the pile. This is a major shortcoming of this method. Often the loss of force due to the use of a piling cushion can be tolerated, since in terms of penetration depth, it is compensated for to a certain extent by the longer duration. But in other cases, the pile driver's maximum power is needed to overcome skin friction and soil resistance. In these cases, an increase of time without loss of force would also require a larger hammer mass (NEHLS et al. 2007). However, numerical calculations by NEUBER & UHL (2012) showed that prolonging the pulse duration did not impair the piling process until soil resistance or embedment depths were very high. Usually, with a worse driveability using similar impact energy the required penetration of a pile can be achieved by increasing the number of strikes (NEUBER & UHL 2012).

The experiments of the *Washington State Department of Transportation* to investigate the effectiveness of piling cushions of plywood, *Micarta* and *Nylon* showed that plywood compresses easily with each pile strike and then does not transfer the energy from the hammer to the pile efficiently enough. Piling cushions partially absorb the impact energy which cannot be dissipated under a closed anvil (NEHLS et al. 2007). Safety is also an issue because wood has a tendency to catch fire when being used as a piling cushion, which would hamper regular use of this material. *Micarta* and *Nylon*, although more expensive than wood, can be re-used on several piles before they need to be replaced. They do not catch fire, and are compressed to a minor extent. Based on these results it appears that *Micarta* would be the best choice for piling cushion material, as this material achieved the next best sound pressure level reductions while retaining hammer efficiencies and also minimising safety hazards (LAUGHLIN 2006). Piling cushions can be used in combination with other noise mitigation measures, such as bubble curtains, cofferdams, and isolation casings, to provide additional noise reduction (CALTRANS 2009). This feature makes the potential of this technique especially interesting and warrants further investigation.

Optimisation of Piling Components

The optimisation of piling components by means of the transient finite element model by MENCK and CADFEM (chapter 4.6.1) was validated with offshore noise measurements. A comparison of the sound pressure measured at *FINO 3* with the results of the model revealed consistent figures of the relevant amplitude (Figure 38) (STEINHAGEN & MOOS-RAINER 2011).

Up to now modelling was used to demonstrate the relevant forces within the system. An acoustic optimisation of the entire piling procedure has not been performed so far, hence no indication of the possible noise reduction potential is available. Probably it will be lower than the noise reduction provided by a bubble curtain. This method may be used in conjunction with other noise mitigation

measures when pile driving noise cannot be reduced below the threshold value with other technical measures alone, or for small piles that only need little noise reduction in order to reach the threshold value.

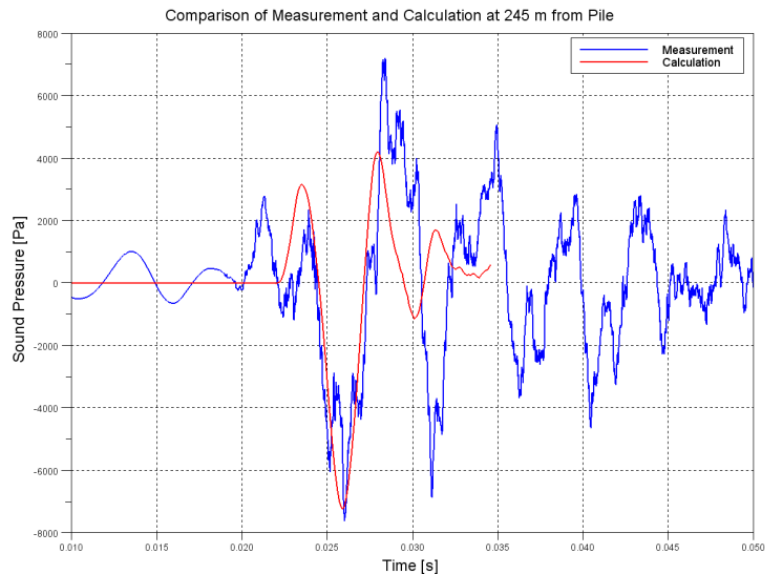

Figure 38: Comparison between the sound pressure measured during piling of the *FINO 3* monopile (blue line) with the modelling results (red line, distance to the sound source 245 m, impact energy 160 kJ) (source: STEINHAGEN 2009)

4.6.2.2 State of Development

Prolongation of Pulse Duration

The idea of prolonging the pulse duration by means of a piling cushion between hammer and pile is in the experimental stage for large pile diameters. According to available information, the use of piling cushions of various materials seems to be restricted to small pile diameters of about 0.3 m. Piling cushions are often used primarily as a means of protecting the equipment and not to mitigate sound emissions. However, it can be deduced from this fact that piling cushions constitute proven technology for small pile diameters of about 0.3 m. The suitability of this method has been demonstrated - again for very small piles - for the materials *Micarta* and *Nylon*, while retaining hammer efficiency and minimising safety hazards (LAUGHLIN 2006). Currently there is no information on a possible application under offshore conditions with pile diameters of several meters and very large hammers that last for longer than only a few pile strikes. This may be due to the fact that in Germany first tests were not successful. Modelling results of a pile cushion at the *FINO 1* pile (\varnothing 1.5 m) were positive and investigations at *FINO 2* (\varnothing 3.3 m) demonstrated that a coiled steel cable (Figure 37) reduced the noise level for a few hammer strikes, thereby demonstrating the suitability of the method in principle. However, a long-term technical implementation of this idea is still pending.

Also, due to the absorption of impact energy and the resulting heat generation under the closed anvil the use of piling cushions is evidently limited to small pile diameters. However, the cushions do not last very long and must be replaced frequently which adds to costs in downtime.

Optimisation of Piling Components

The finite element modelling for the optimisation of the variable components within the piling process with respect to noise reduction is in the experimental stage. After completion of the research project *Schall 3* the model is currently further developed in the project *BORA* with the aim of a user-

friendly calculation method (see also [chapter 6](#)). Priority objective of the finite element modelling is the development of a prediction tool for sound emissions in the acoustic near-field and far-field. A further objective is a comparison of different hammer and pile combinations as well as noise mitigation measures during pile driving (initially without the application of noise mitigation techniques), together with a comparison in the effectiveness of various combinations of hammer, anvil and pile or with other noise mitigation measures in order to detect possible mitigation potentials.

A model to describe sound generation and transmission during pile driving is available in principle. This does not yet consider the various noise mitigation technologies. This model has been confirmed in a first validation ([Figure 38](#)) (STEINHAGEN 2009, STEINHAGEN & MOOS-RAINER 2011). Such a validation may be performed e.g. by comparing values measured during a real pile driving operation with the results of the model for the same constellation of all variable components. However, in future more validations will be required, e.g. comparisons between calculations and measurements in the frame of various projects. Furthermore the extension of computer science to predict sound emissions in the acoustic near- and far-field as well as without and with noise mitigation techniques is required. This is the subject of on-going research (*BORA* 2012, [chapter 6](#)).

Following an optimisation in this respect, the model can serve the targeted adaptation of the technical components within the pile driving process with the aim of noise mitigation. By the choice of input parameters a wide range of combinations of all technical components is possible from which the best-suited variant with respect to noise mitigation can be chosen. It remains to be seen if the optimisation of the piling components with regard to noise mitigation will have a positive or negative effect on cost effectiveness (e.g., with regard to material requirements). However, it enables additional noise reduction, which can be used in combination with other noise mitigation measures in order to comply with the legal noise limit even with large monopiles.

5 Low-Noise Foundations

5.1 Vibratory Pile Driving

Installing foundation piles by a combination of vibratory pile driving and impact pile driving contributes to the overall noise reduction as less time is needed for impact piling. Vibratory pile driving is a technique which is used to make the pile oscillate at a low frequency of about 20 Hz by means of rotating weights. These vibrating movements enable penetration into the seabed. Sound at frequencies below a so-called lower cut-off frequency does not propagate in shallow waters like those prevailing in the North Sea. However, harmonics at higher frequencies are also emitted. These determine the sound level in water throughout the operation of the vibratory pile driver (BETKE & MATUSCHEK 2012). Experience with vibratory pile driving was gained at reference projects in German waters with pile diameters of up to 6.5 m at the OWF *Riffgat*, where the piles were vibrated up to about half of their final embedment depth by this technique ([chapter 5.1.1](#)). Meanwhile, the successful complete installation of 5 m monopiles using only vibratory pile driving is reported from China (SALEEM 2011).

Even if only a part of the overall embedment depth can be reached by vibratory pile driving, the number of impact piling strikes required to reach the final mounting would still be reduced, which in turn would diminish the impact zones for marine mammals and fishes. This effect is based on the fact that the adverse effect of impulsive sound increases with the number of blows, as energy accumulates over time in the ears of the organisms (NMFS 2007, SOUTHWALL et al. 2007).

HASTINGS & POPPER (2005), STADLER & WOODBURY (2007) and CALTRANS (2009) propose a formula to calculate the cumulative SEL (SEL_{cum}) level based on the *Equal Energy Hypothesis*¹⁶ (EEH). The calculation is based on the assumption that the animal is exposed to identical SEL values with each blow, and the tissue of the inner ear does not recover between sound impulses. According to this approach the following physical relationship is assumed:

$$SEL_{cum} = SEL_{ss} + 10 \cdot \log(\text{number of strikes})$$

[with SEL_{cum} = cumulative SEL, and SEL_{ss} = single strike-SEL]

5.1.1 Experience with Vibratory Piling

A comparison of sound levels emitted by a vibratory pile driver and those of an impact pile driver was performed by ELMER et al. (2007a). During anchoring of a foundation pile (diameter 1.5 m, length 25 m) at harbour construction works, sound emissions of an impact pile driver (MHU 270 T) and a vibratory pile driver (PVE 110 M Diesko Vibrators) were measured. In normal mode, sound levels during vibratory pile driving were about 15-20 dB lower than those of the impact pile driver (ELMER et al. 2007a, BETKE & MATUSCHEK 2010). However, deep compact clay layers are a problem for vibratory pile drivers as the pile gets stuck in the cohesive soil and the vibration cannot achieve further advance of the pile. Sound levels increase and the frequency range shifts towards higher frequencies (main energy in normal mode <1,000 Hz, when the pile is stuck 300-2,500 Hz) ([Figure 39](#)) (ELMER et al. 2007a, BETKE & MATUSCHEK 2010).

Three piles of a **test- and demonstration turbine by BARD Engineering GmbH** in the river Jade at Hooksiel were anchored by a combination of vibratory and impact pile driving. About half of the embedment depth of 44 m was achieved by vibratory pile driving, hence impact pile driving only had to be applied for the final 22 m. Based on conservative assumptions, when exclusively using impact pile

¹⁶ The EEH states that equal amounts of sound energy will produce equal amounts of hearing impairment.

driving, a total of about 6,500 blows per pile would have been expected (JÖRN UECKER, *IMS Ingenieurgesellschaft mbH*, Hamburg, pers. comm.). This number could be reduced by the accessory application of a vibratory pile driver to 2,200 to 5,000 blows per pile. It has to be kept in mind that due to its elastic effect an intermediate soft peat layer required a particularly high number of blows.

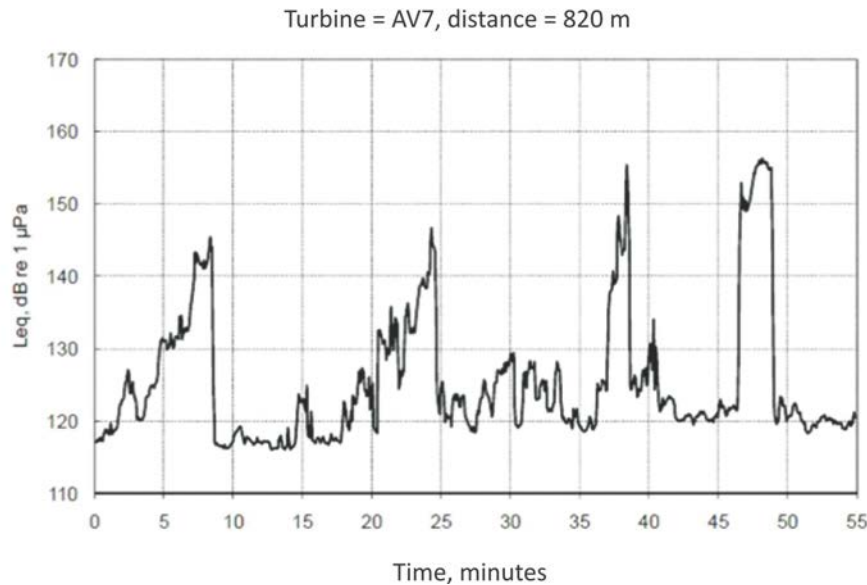

Figure 39: Sound level during the application of a vibratory pile driver in the OWF *alpha ventus* at turbine AV7 (averaging period 5 s) (source: BETKE & MATUSCHEK 2010, modified)

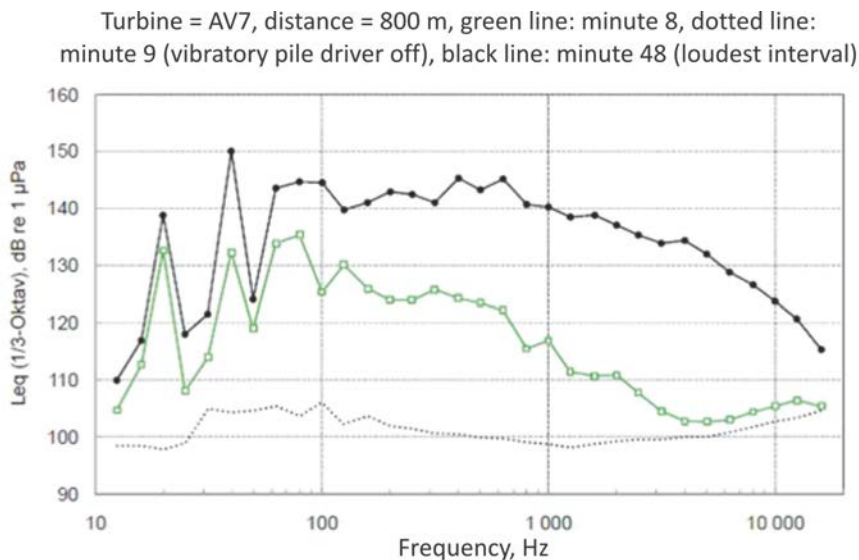

Figure 40: Spectral noise level during the application of a vibratory pile driver in the OWF *alpha ventus* at turbine AV7 at selected times (source: BETKE & MATUSCHEK 2010, modified)

At the OFW *alpha ventus* a vibratory pile driver was applied in combination with an impact pile driver to anchor the tripods for six *Multibrid* turbines. The foundation piles had a diameter of 2.6 m and the embedment depth was about 30 m. By means of the vibratory pile driver, only the initial meters (maximum 9 m) could be driven into the ground. The vibratory pile driver was applied between 8 and 20 minutes for every pile. The underwater sound levels varied during this period (Figure 40), but the sum level of about 142 dB (SEL) (157 dB (SEL) in the loudest period) at 750 m distance were substan-

tially lower than the sound levels of the impact pile driver of 167 dB (SEL)¹⁷ (Figure 40, Figure 41). However, a high frequency tonal component went with the regular operational noise and was audible especially at the end of the piling process as a high buzzing sound (BETKE & MATUSCHEK 2010).

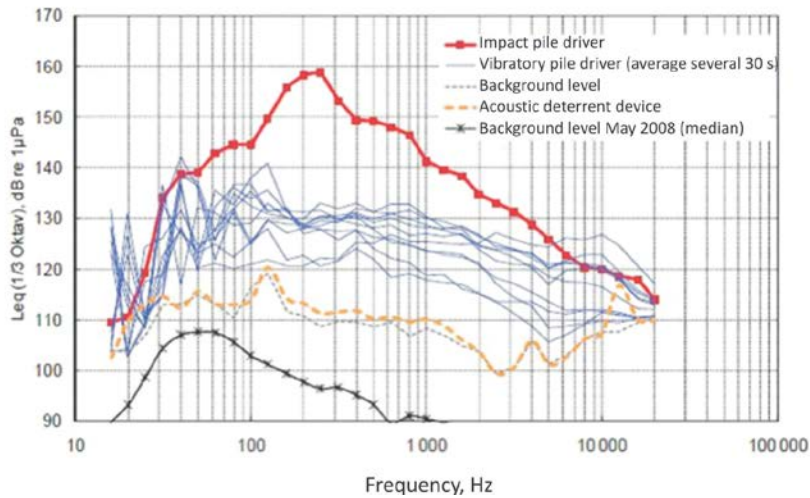

Figure 41: Sound level during the application of a vibratory pile driver in the OWF *alpha ventus* at the converter platform AVO (BETKE & MATUSCHEK 2009), compared to the impact pile driver and the background noise, measured at 1.2 km distance (source: BETKE & MATUSCHEK 2010, modified)

During the construction of the **OWF Riffgat** the first part of the embedment depth was also reached by vibratory piling (GERKE & BELLMANN 2012). At sandy sites it was possible to reach approximately 13-21 m of the final embedment depth of 29-32 m using the vibratory method. At sites with more cohesive soils (silt/clay) the piles could be vibrated into the seabed up to 18-24 m of the final depth of 35-41 m. Vibratory piling lasted approximately 1-2 hours per pile at both sites.

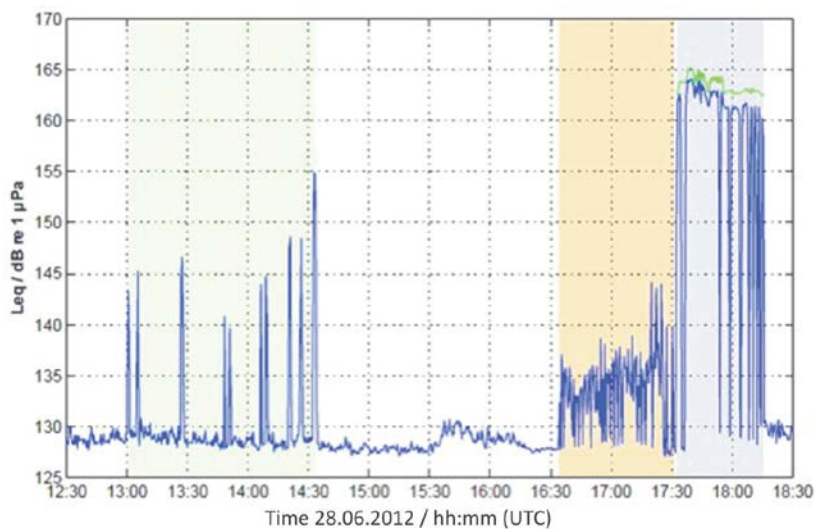

Figure 42: Temporal variation of the equivalent continuous sound pressure level Leq (averaged over 30 s) during piling works at pile R14 at a distance of approximately 750 m (blue line). Green line: single event sound pressure level (SEL) during impact piling. Background colours: light green= vibratory piling, brownish=use of acoustic seal scarer and pinger, blue= impact piling (source: GERKE & BELLMANN 2012, modified)

The equivalent continuous sound pressure level Leq (averaged over 30 s) measured during vibratory piling is shown in Figure 42 (light green background colour, 13:00 to 14:30). The median Leq was

¹⁷ Calculated from Figure 40 and Figure 41 (BETKE & MATUSCHEK 2010). Conversion to 750 m distance: $15 \log R$.

145 dB. The emissions of the vibratory pile driver consisted of a main component around 17-18 Hz, i.e. the rotation speed of the vibrators and their harmonics (integer multiples of this fundamental frequency) at 36 Hz, 52 Hz and 70 Hz, etc. (GERKE & BELLMANN 2012).

5.1.2 Valuation of Vibratory Piling

5.1.2.1 Noise Mitigation

In various projects, the sound levels emitted during vibratory pile driving were about 15-20 dB lower than those of impact pile drivers ([chapter 5.1](#)). However, both the investigations at harbour construction works (ELMER et al (2007a) and at the OWF *alpha ventus* (BETKE & MATUSCHEK 2010) showed that high frequency tonal components in the frequency range up to over 10 kHz occurred ([see above](#)). The overall impact of impulsive sound on marine organisms cannot be directly compared to that of continuous sound as the adverse impact of continuous sound might also accumulate over time.

5.1.2.2 Development Status

In the offshore sector, the application of vibratory pile driving in combination with impact pile driving is proven technology. The equipment is market-available from several providers. Long-standing experiences from various construction projects, e.g. bridge construction, are available. Vibratory pile driving has also been successfully applied for the installation of offshore wind turbines ([see above](#)).

However, the maximum embedment depths obtainable by vibratory pile driving depends on several parameters such as soil conditions, pile diameter, wall thickness, vibration characteristics of the pile and dimension of the vibratory pile driver. Hence, not all piles can be driven up to the required embedment depth using this technique. Based on recent experiences, with today's technology an exclusive application of vibratory pile driving is not possible due to the large embedment depths and the possible occurrence of adverse soil conditions (e.g. the occurrence of cohesive soil like in compact clay layers). Normally, vibratory pile driving is only applied in combination with impact pile driving as it is debated that the final stability under load may only be achieved by impact pile driving¹⁸, therefore loud impulsive sound emissions cannot be completely avoided.

However, driving foundation piles by a combination of vibratory pile driving and impact pile driving reduces the overall noise, which in turn reduces the impact zones for marine mammals and fish ([see above](#)). According to the formula for calculating the cumulative SEL ([chapter 5.1](#)), reducing the number of strikes by 50 % would only reduce the cumulative SEL by 3 dB. Hence the calculated injury zones for marine mammals (SOUTHALL et al. 2007) and fish (FHVG 2008) would not be significantly diminished. But under certain circumstances the period of disturbance is reduced. Furthermore, it has to be kept in mind that vibratory pile driving is primarily used to penetrate the upper meters of the overall embedment depth where the sediments are usually less compact than in deeper layers. Hence, applying this technique would basically avoid pile strikes of comparatively lower energy, while the (louder) blows for the deeper soil layers are still necessary. Therefore the possible noise mitigation by the (additional) application of vibratory pile driving has to be considered on a case-by-case basis.

¹⁸ The same stability may be achieved with the exclusive use of vibratory piling compared to impact piling. Experimental findings (LAMMERTZ 2008) and calculations (LAMMERTZ 2004) revealed that in loose to medium-dense deposits, even higher load bearing capacities can be achieved by vibratory pile driving than by impulsive piling. However, the calculation method applied is purely experimental and according to the relevant DIN standard this derivation is not valid (MAGNUS GEDUHN, *IMS Ingenieurgesellschaft mbH*, Hamburg, pers. comm.). Apparently there remains more need for research on this aspect.

5.2 Drilled Foundations

A foundation method which is currently being further developed by a number of suppliers (**Ballast Nedam**: [chapter 5.2.1](#), **Herrenknecht/Hochtief**: [chapter 5.2.2](#) and **Fugro Seacore**: [chapter 5.2.3](#)) is a monopile foundation which is embedded in the seabed using different drilling technologies and monopile concepts. *Ballast Nedam* as well as *Herrenknecht* have considerable experience from a variety of onshore projects (e.g., wastewater systems and transport infrastructure projects) using vertical drilling technology. *Fugro Seacore Ltd.* is already using offshore vertical drilling technology to date for monopile or frame construction foundations. However, their application is limited to combined use with impact pile driving in unfavourable soil conditions (*Drive Drill Drive*) or in rocky seabeds in which piles can be grouted. An advantage of drilled foundations is that lower noise emissions can be expected compared to impact pile driving. Other advantages relate to the independence of the local geology due to drilling capabilities within solid (rocky), cohesive or over-consolidated formations. Differences between drilling systems are pointed out in [Table 4](#).

Table 4: Various vertical drilling technologies for offshore deep foundations

	Ballast Nedam	Herrenknecht/Hochtief	Fugro Seacore
Suitable foundation variants	Mainly for prestressed concrete piles	Initially for steel monopiles, concrete monopiles not precluded	Experiences with steel monopiles, concrete monopiles not precluded, application for jackets under development
Shaft drilling machine*	Full-face excavating machine	Partial face excavating machine	Full-face excavating machine
Attachment of drilling machine	Within the monopile	Within the monopile	Above the pile head attached to vertical <i>leader legs</i> , torque transmission by means of a drill pipe
Drilled hole diameter	> pile diameter	> pile diameter	= pile diameter
Filling of annular gap	Drill fluid added in the course of penetration	Special mortar added in the course of penetration	No annular gap
Penetration of the pile	By weight, lubricated by drill fluid	By weight, lubricated by special mortar	By weight, thin lubricating film, hydraulic pressure
* For vertical drilling, different types of drilling machines are available. The full-face excavating machine is a drilling machine which excavates the full cross section of the shaft in a single work step (<i>Ballast Nedam</i> , <i>Fugro Seacore</i>). The opposite is a partial-face excavating machine with its hydraulically controlled rotary grinder making concentric circular movements at the shaft bottom (<i>Herrenknecht/Hochtief</i>).			

The material of the pile is of minor importance for the drilling technology. However, particular requirements have to be met by cranes or the jack-up rig due to the much higher weight of concrete monopiles compared to steel piles. *Ballast Nedam's* concept is based on concrete monopiles which they consider the most economic ([chapter 5.2.4.2](#)). The other companies mentioned regard concrete monopiles as a future option. Advantages are seen in the higher stiffness of concrete piles, especially at large water depths (PETER CLUTTERBUCK, *Fugro Seacore Ltd.*, Falmouth UK, pers comm.). Until recently it was argued that the use of concrete monopiles would be limited to only a few heavy duty floating cranes which are however much more dependent on weather conditions than jack-up rigs. An innovative leader leg pile handling system, which has been successfully used for steel piles of approximately 300 t, can make a crane redundant if adequately dimensioned. It consists of two vertical leader legs with a gripper unit between them. The floating monopile is introduced between the leader legs and then raised by the gripper unit by means of hydraulic rams ([Figure 48](#)).

5.2.1 Ballast Nedam

The Dutch company **Ballast Nedam** in co-operation with *MT Piling* has developed a new foundation concept which allows the founding of concrete monopiles by means of vertical shaft drilling. The *Ballast Nedam* concept is mainly based on two different variations of pre-stressed concrete piles for different loads (Table 5).

Table 5: *Ballast Nedam's* foundation concept for the OWF *Kriegers Flak* using prefabricated concrete monopiles for 3.6 MW or 5 MW wind turbines (source: VAN DE BRUG 2009, BALLAST NEDAM 2012).

Parameter	3,6 MW turbine	5,0 MW turbine
Outer pile diameter	6.5 m	6.9 m
Wall thickness	0.5 m	0.7 m
Inner pile diameter	5.5 m	5.5 m
Pile length	61 m	64 m
Concrete mass	1,400 t	2,150 t



Figure 43: Drilled concrete monopile concept of *Ballast Nedam*: positioning (left), drill head before installation within the monopile (middle), drilling operation and penetration of the monopile (right) (source: VAN DE BRUG 2011)

The concept of the pile installation is as follows: The monopile which is pre-fabricated of concrete ring elements is transported afloat to the offshore site. The floating monopile is upended by the heavy lift vessel *Svanen* and positioned in the guiding frame. The monopile settles several metres into the seabed due to its weight, after which the drilling machine is inserted into the monopile where it is locked hydraulically. The cutter head can be extended from the inner diameter to the outer diameter of the concrete monopile in order to drill either inside or underneath the pile, depending on soil conditions. By excavating sandy material from the inside (Figure 44, left) the pile penetrates deeper into the ground. In very dense strata or rocky or cretaceous formations, the extended cutter head drills under the pile (Figure 44, right) (VAN DE BRUG 2011). The cutter head does not need to be replaced but can simply switch from one adjustment to another. Stones up to a diameter of 50 cm can be crushed whereas larger boulders may have to be removed (VAN DE BRUG 2009).

With drilling progress the monopile is emplaced to its final embedment depth (Figure 43). A steel cutting shoe fitted to the bottom end of the monopile cuts into the sediment, creating an overcut. This reduces the friction along the shaft of the piles and allows the pile to penetrate further into the seabed. The stability of the monopile is reached by a self-hardening drill fluid in the resulting annular gap, which has lubricating properties when the pile is still in motion (VAN DE BRUG 2009, 2011).

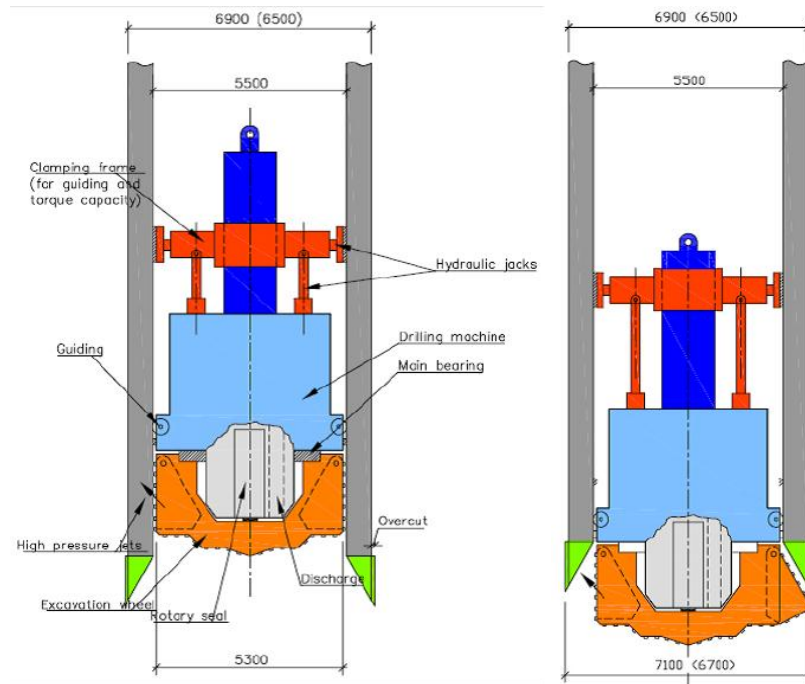

Figure 44: Ballast Nedam's drilled concrete monopile concept: Details of the drill head with extendable diameter: drilling inside (left) and below (right) the concrete monopile (source: VAN DE BRUG 2011)

5.2.2 Offshore Foundation Drilling (OFD) (Herrenknecht/Hochtief)

The *OFD* drilling process— similar to *Ballast Nedam's* technology – is designed to anchor monopiles (preferably conventional steel monopiles due to their lower weight and thus fewer requirements with respect to loading and lifting capacity) safely to the seabed by vertical drilling. The technological basis is the **Vertical Shaft Sinking Machine (VSM)** by *Herrenknecht AG*, Schwanau/Germany, which is already in use onshore and can operate under up to 100 m of groundwater. Even low-driveable or non-driveable soils can be drilled. The *VSM* consists of two main components, the immersion unit and the excavating machine (Figure 45) (ROSENBERGER et al. 2011). A hydraulically controlled telescopic boom with rotary grinder can turn horizontally into both directions by 190° and thus enables the drilling of a circular shaft of diameters up to 10 m. It can drill inside and underneath the monopile as required by respective soil conditions. The excavated material is removed through pipes to a separation plant located on the jack-up vessel. Separated water is pumped back.

As a partial-face excavating machine the *VSM* is more flexible with respect to shaft diameter and shape compared to full-face excavating machines (Table 4). The shaft diameter is not dictated by the cutting head, which also enables the design of tapered pile heads. The drilling equipment can be folded during installation or de-installation and thus fits through narrower parts of the pile. As in the *Ballast Nedam* concept the *VSM* creates a slight overcut in which a specific mortar is added during the course of penetration. The cohesion of this mortar is broken up when the pile sinks into the sea bottom due to shear force. When the pile rests at its final depth, the mortar hardens.

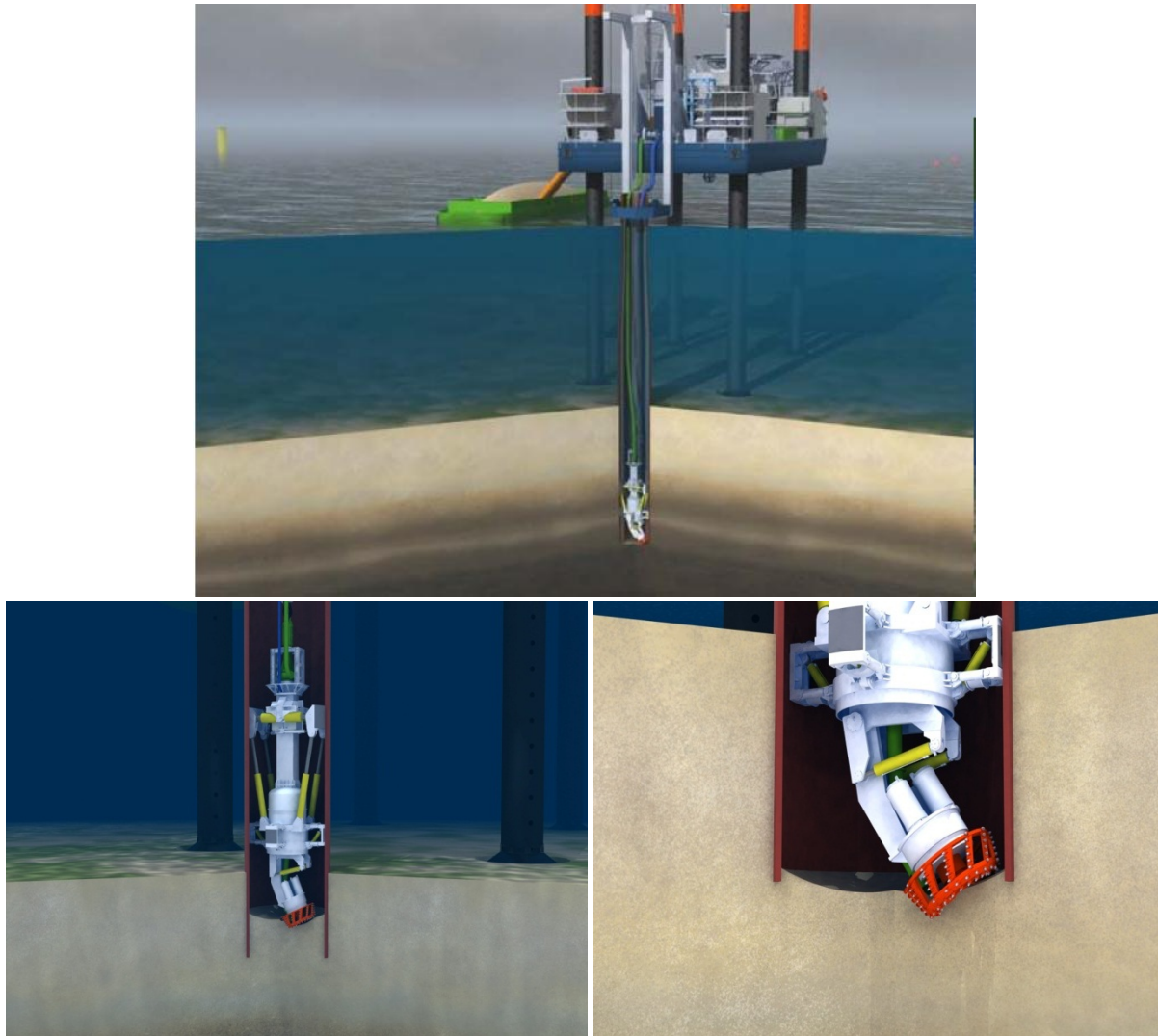

Figure 45: Offshore Foundation Drilling (OFD) concept (source: Hochtief Solutions AG, Essen)

5.2.3 Fugro Seacore

The British company *Fugro Seacore Ltd.* is a pioneer in using vertical drilling machines in marine applications. They apply hydraulic *top drive* methods, during which propulsion is generated above the pile head and the axial force is transmitted to the bottom end of the pile by means of a drill pipe (Figure 46). The cut spoil is flushed out with sea water. The system can be adapted to a variety of soil conditions (from silt or sand to rock) by using different cutting bits on the drill head. Due to the long-standing experience with different drilling techniques suitable installation methods adapted to local conditions and favoured foundation method can be developed.

In contrast to the two previous concepts *Fugro Seacore* provides for drilling with exactly the outer diameter of the pile. For this, the wear and tear of the cutting bits has to be taken into account. Depending on seabed conditions, the pile can be lubricated with a thin film of a rapidly degrading material to allow for better penetration. In an application at a gas platform, for instance, a mud injection facility was installed to create a mud slip coat around the piles (SEACORE 2012). Additionally the leader leg pile handling system (Figure 48) can control self-weight advance and provide additional vertical thrust (PETER CLUTTERBUCK, *Fugro Seacore Ltd.*, Falmouth UK, pers comm.).

In order to remove boulders or bedrock below the pile and to reduce soil resistance, *Pile Relief Drilling* can be used. Very hard strata can be destroyed using a down-the-hole hammer which shatters the rock like a chisel with a high impact rate. Another method used by *Fugro Seacore* is *Drive Drill Drive* in which drilling is employed in various unfavourable strata (e.g. thick layers of stiff boulder clay, limestone or bedrock) in combination with supplementary impact pile driving.



Figure 46: Operation of a marine vertical drilling machine off the coast of Flamanville, Normandy. The outfall installation of a nuclear power plant was founded in strong bedrock formations by drilling 63 m deep with drill head diameters of 5.85 m and 6.35 m (source: *Fugro Seacore Ltd.*)

5.2.4 Valuation of Drilled Foundations

5.2.4.1 Noise Mitigation

Sound measurements were conducted during seabed drilling works of *Fugro Seacore* to create rock sockets with a diameter of 1.15 m for the installation of a tidal generator in the bedrock of Strangford Lough (Northern Ireland). Measurements taken at distances of 28 m and 2,130 m and back-calculated to the source level resulted in a one second sound pressure level of 162 dB re 1 μ Pa 1m. If drilling was performed inside a concrete monopile the sound levels could even be less (PETER CLUTTERBUCK, *Fugro Seacore Ltd.*, Falmouth UK, pers comm.). Also, in soft sediments sound emissions could be lower. For both variants no measurements are available, however. If a down-the-hole hammer is operated in bedrock, which in contrast to hydraulic top drive methods could generate additional noise by the hammering impact, the overall sound emissions may be even higher. Sound measurements during operation of a down-the-hole hammer at a pier in shallow water (less than 6 m depth, Becher's Bay, Santa Rosa Island, California) resulted in sound pressure levels of 136 to 182 dB (rms) at 1 m (DAZEY et al. 2012). Compared to exclusive impact pile driving, a minor reduction in noise emissions is expected during *Drive Drill Drive* resulting from a lower number of blows and the use of less impact energy.

Sound measurements of drill operations of *Ballast Nedam* are not known. The *Ballast Nedam* concept is explicitly offered as a technically profound concept not limited by noise (VAN DE BRUG 2009).

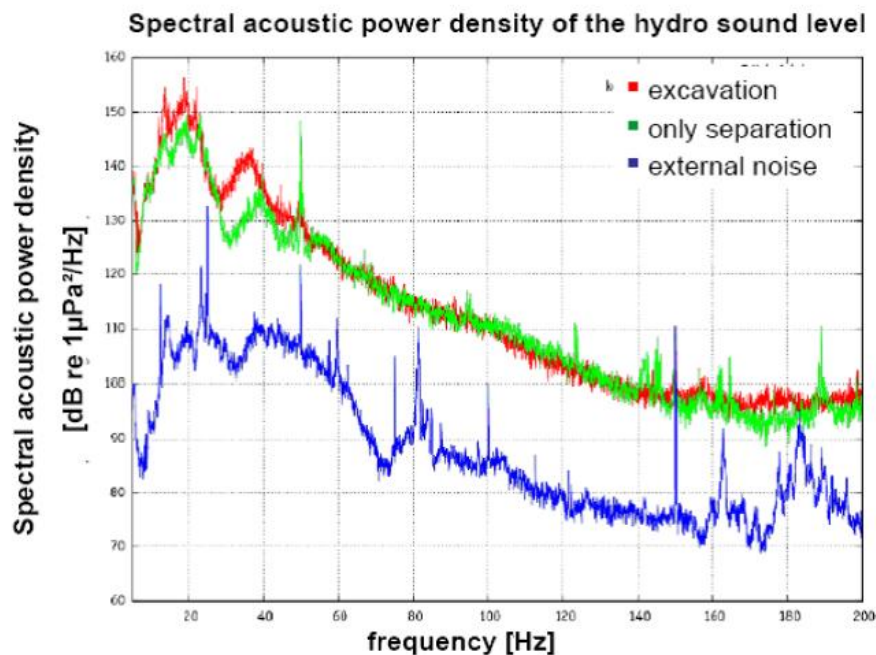

Figure 47: Hydrosound measurement during the operation of a *Herrenknecht* Vertical Shaft Sinking Machine VSM (source: AHRENS & WIEGAND 2009)

For the valuation of noise emissions to be expected from the *Herrenknecht VSM* a number of tests were conducted in co-operation with the Oldenburg-based *Institute of Technical and Applied Physics (ITAP)* (Figure 47). During various operational phases of the VSM in drilling works of a vertical shaft (diameter: 5 m, depth: 39 m, 25 m below groundwater level) in the underground system in Naples, measurements of structure- and water-borne sound generation were taken. From these measurements the potential noise emissions in an offshore application were predicted (RUSTEMEIER et al. 2012). The prediction resulted in a broadband equivalent continuous sound pressure level of approx-

imately 160 dB re 1 μ Pa 1m, which is in the same order of magnitude as the measured sound of the *Fugro Seacore* system. The *VSM* emitted mainly low-frequency noise below 200 Hz. The highest amplitude was measured around 20 Hz (Figure 47). The sound spectrum shows that emissions of the separation unit (pumping noise during separation of water and cut spoil) dominate the noise, whose level is only 3 dB lower than the measured noise in combination with the drill head under load. Sound emitted by the drill head mainly covered the spectrum of 10-40 Hz. Extrapolated to a distance of 750 m this measured value corresponded to a broadband equivalent continuous sound pressure level of 117 dB. The predicted peak level is 122 dB (AHRENS & WIEGAND 2009, HERRENKNECHT AG 2009, RUSTEMEIER et al. 2012).

Sound measurements under offshore conditions are not yet available for the *VSM*. The measurements in Naples (see above) show that noise emitted by drilling operations is much lower than impact pile driving noise. However, drilling generates continuous noise whose impact on the marine environment is not directly comparable to that of impulsive noise (SOUTHALL et al. 2007). The measured broadband levels are lower than those emitted by several large vessels (RICHARDSON et al. 1995) so that for drilling operations a lower environmental exposure can be expected than during the passage of a vessel. However, drilling of large boulders in particular may result in higher levels than predicted in the study. Sound transmission into the water column is probably dependent on shaft and water depth. The operation within concrete monopiles or below the sediment surface may result in additional noise reduction. Finally, the sound level at a distance of 750 m from offshore wind power plants in the North Sea could be lower than predicted by the study because very low frequencies of drilling sound are not transmitted at shallow water depths (approximately 40 m).

5.2.4.2 Development Status

An economic application of drilled monopiles is likely, at least for certain sites. Drilling is already standard in bedrock, sandstone or limestone as in these sediments there is no competition to impact pile driving. With the increasing size of future offshore wind turbines, drilling techniques have the potential to replace the currently often used frame constructions by monopiles. The use of large monopiles which are not driveable with current technology would become feasible. This would result in lower material requirements and in a cost advantage of drilled monopiles (GIPPERICH 2012).

A further cost advantage would result from the use of concrete rather than steel monopiles. For this reason *Ballast Nedam's* method relies on concrete monopiles whereas the other suppliers of drilling technology initially prefer steel monopiles due to their lower weight, but keep concrete monopiles as an option for the future. The use of reinforced concrete monopiles results in a better economic benefit than current use of steel monopiles or frame constructions such as jackets. Currently, 65% of foundation costs arise from manufacturing of the foundation structures. A significant cost reduction potential can be deduced from this observation (ROSENBERGER et al. 2011). The manufacturing costs of concrete piles are low compared to those of steel piles. VAN DE BRUG (2011) states that the price of a steel monopile is about 4-5 times the price of a pre-fabricated concrete monopile, and the price of a jacket foundation is up to 15 times higher. Further advantages are the price stability of concrete and its local production at nearly unlimited fabrication capacity. Moreover, reinforced concrete is less vulnerable to corrosion in sea water so that no cathodic corrosion protection is necessary. If jack-up vessels with an appropriate load carrying capacity become available in the future, the next development step towards concrete piles is also planned in the OFD technology (CHRISTOF GIPPERICH, *Hochtief Solutions AG*, Essen, pers. comm.). *Fugro Seacore* takes a different approach with their innovative leader leg pile handling system, which can also result in the use of concrete monopiles, provided that it is possible to increase the lifting capacity and dimensioning of the system that is already available now.

Ballast Nedam: Concrete drilled monopiles are currently still in the concept stage. The installation by vertical drilling is technically feasible and the lifting capacity of the heavy lift vessel *Svanen* (8,700 t) is more than adequate to carry the weight of concrete monopiles (VAN DE BRUG 2009). However, the installation based on a floating crane is more dependent on weather and currents than that of a jack-up rig-based installation.

Onshore tests are planned for the near future to demonstrate the drilling technology and to investigate the bedding behaviour and the stability of the monopiles (MAARTEN VAN DER VEEN, *Ballast Nedam*, Nieuwegein/NL, pers. comm.). An offshore demonstration project would be the next step. Within the research project *FLOW (Far and Large Offshore Wind)*, a demonstration project is planned in the North Sea 75 km west of Callantsoog/DenHelder at a water depth of 35 m (www.flow-windpark.nl).

OFD: Offshore Foundation Drilling is currently in the pilot stage. After comprehensive studies on the technical and economic feasibility of the installation of offshore wind power plants using the *VSM* (HERRENKNECHT 2010) and various model tests, a prototype of an OFD partial-face excavation machine for monopile diameters of up to 7.5 m is under construction. The completion date is scheduled for October 2013, followed by a nearshore test in the 4th quarter of 2013. An offshore prototype test is scheduled for the beginning of 2014 (GIPPERICH 2012).

Meanwhile the special mortar for the annular gap has been developed and its pumpability and processability for annular gaps of 2.5 and 5 cm have been successfully tested (GIPPERICH 2012). A numeric analysis for medium densely or densely bedded sands has shown that a monopile founded in the seabed by means of *VSM* technology has the same or an even better bedding behaviour with respect to lateral displacement than a driven pile (AHRENS & WIEGAND 2009). A large-scale onshore experiment¹⁹ has been conducted including stress tests at two drilled monopile prototypes at a scale of approximately 1:8 compared to two driven piles of the same dimension. These experiments on the bedding behaviour and process engineering during injection of the special mortar into the annular gap are still under analysis. Preliminary results are promising (CHRISTOPH BUDACH, *Hochtief Solutions AG*, Essen, pers. comm.). As a next step after full data analysis and extrapolation of the measured data to full scale conditions, a nearshore test is planned. Subsequently it will be necessary to prove in a full-scale offshore test that this technology can be used under the same wave, current and wind conditions as impact pile driving of large monopiles. Market maturity could be reached from 2014 on after a successful offshore test of a prototype will have been completed (ROSENBERGER et al. 2011, GIPPERICH 2012). By using the *OFD*-technology for the installation of large monopiles a cost advantage is expected due to the replacement of expensive frame constructions like jackets, tripods and tripiles with cheaper monopiles.

Among others, the installation time is a critical factor with respect to the economic feasibility of this technology. With the optimisation of the cutting head geometry and pump output the excavation speed in the *OFD* technology has already been improved compared to the original *VSM*. Further, the *VSM* has been adapted to offshore applications by using a variable gripper system for the mounting inside the monopile. This has been tested in a model (ROSENBERGER et al. 2011, GIPPERICH 2012). Next to monopile installations, concepts for frame constructions like jackets, tripods or tripiles are also under development.

Fugro Seacore: Vertical drilling is already being used in offshore areas. Drilling is applied for various reasons, most of which do not aim at mitigating underwater noise. For instance, seabeds like bed-rock, bolder clay or soil interspersed with large stones are simply not driveable by impact pile driving. Further, underreaming or relief drilling underneath the pile can prevent fatigue of the pile by using a smaller number of blows with decreased impact energy.

¹⁹ Investigations were performed in cooperation with the Federal Institute for Materials Research and Testing, Berlin, and the Institute of Geotechnics, Leibniz University, Hannover.

Therefore, offshore vertical drilling can already be regarded as a proven technology for various deep foundation applications. It is designated for a broad range of applications by using different components and modifications of existing systems. It is also already available on the market. Experience exists from various wind farm installations on a number of soils. Initial knowledge was gathered during the installation of the OWF *Bockstigen* (Gotland, Sweden), which was founded in limestone. In the UK a number of wind farms have been founded on seabeds with mixed layers of sand, boulder clay and sand stone using *Drive Drill Drive*, e. g., the OWFs *North Hoyle* (monopile diameter 4 m, length 25 m), *Gunfleet Sands* (diameter 4.7 m, length 46 m) und *Teeside* (diameter 4.7 m, length up to 51 m).

However, there are still some limitations with respect to certain kinds of seabeds. For exclusively drilled monopiles in e.g. sandy soil without filling of the annular gap, no stability investigations have been made yet.

The use of a *Fugro Seacore leader leg* pile handling system ([Figure 48](#)) makes vertical drilling interesting for the much heavier concrete monopiles even without the use of floating cranes. If adequately dimensioned, it can make a crane redundant. The system consists of two vertical leader legs with a gripping unit between them which lifts the pile presented as a floating object by use of hydraulic rams until it is in a vertical position. So far, it has been used for steel monopiles weighing up to 300 t. For concrete monopiles, jack-up rigs could be used without additional crane capacity, but the leader leg system must be further developed for this application (PETER CLUTTERBUCK, *Fugro Seacore Ltd.*, Falmouth UK, pers. comm.).

Fugro Seacore currently also develops drilling methods to be applied with jacket foundations. In common with *Herrenknecht/Hochtief* and *Ballast Nedam*, *Fugro Seacore* has not yet found parties to join them in any further demonstration trials (PETER CLUTTERBUCK, *Fugro Seacore Ltd.*, Falmouth UK, pers. comm.).

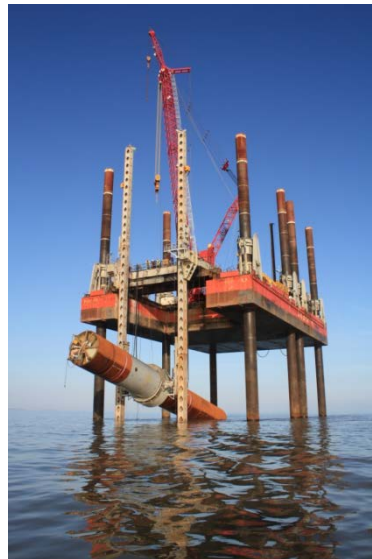

Figure 48: The use of a leader leg pile handling system for monopiles with a weight of 300 t at the OWF *Gunfleet Sands*, if appropriately dimensioned, can make a crane redundant (source: *Fugro Seacore Ltd.*)

5.3 Gravity Base Foundations

Gravity base foundations are large box girders whose stability is achieved by the self-weight of the structure, supplemented by additional ballast. The available models differ in shape and production details. Production takes place onshore and the foundations are shipped to the offshore location where they are settled out. The wind turbine is installed on the foundation at the offshore location and grouted afterwards. Some concepts plan to pre-assemble the turbine completely onshore and transport the complex of foundation and turbine hanging with semi-submersible ships.

5.3.1 Experience with Gravity Base Foundations

Gravity base foundations are already installed in several OWFs at water depths of up to 20 m predominantly in the Baltic Sea, e.g. at *Nysted* and *Middelgrunden* in Denmark, *Lillgrund* in Sweden and *Thornton Bank* in Belgium (Table 6). At their offshore location, most models are additionally ballasted by sand or gravel after being erected. Gravity base foundation mostly consist of a round or hexagonal ground plate with open cave chambers to be filled with ballast, and a shaft reaching beyond the water surface (Figure 49, Figure 50).

In most cases, soil preparation is required to ensure the upright positioning of the structure and scour protections are needed. The ocean floor is excavated until a load-bearing layer or the final embedment depth is reached. During construction of the **OWF Lillgrund**, the building pit was filled with a 50 cm layer of crushed stones in order to produce a plane surface to place the foundations. After the placement, the cave chambers of the ground plate were filled with stones (VATTENFALL 2008, FREISEN 2010).

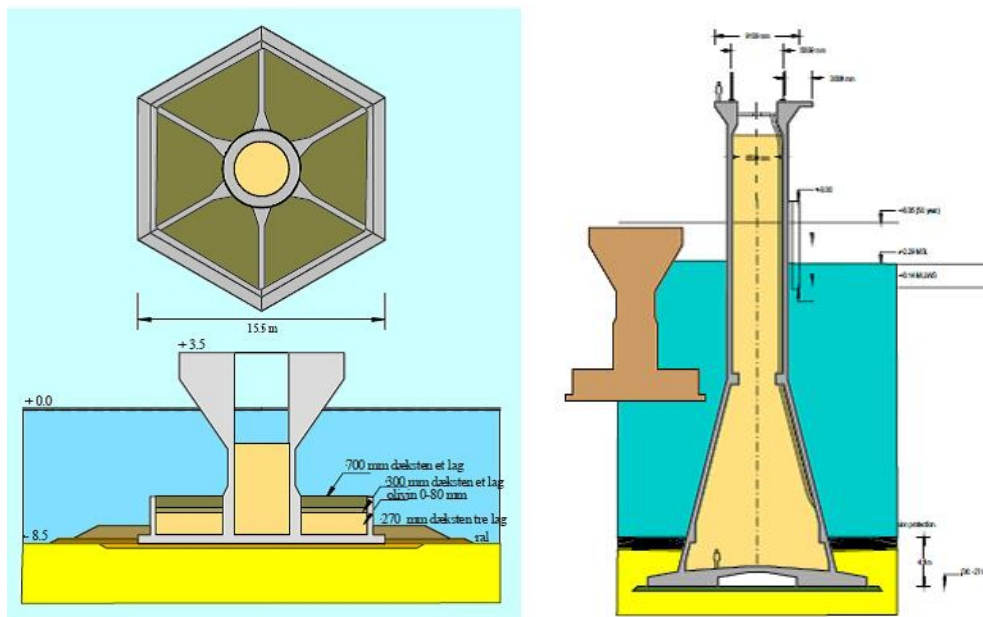

Figure 49: Schematic drawing of the gravity base foundation at the OWF *Nysted* (left side) and comparison of size of the foundation in *Nystedt* and *Thornton Bank* (right side) (source: THOMSEN et al. 2007)

Table 6: Gravity base foundations in the North Sea and Baltic Sea (source of project data: <http://rave.iset.uni-kassel.de>)

Project	Location / Start of operation	Water depth / Distance to shore	Number and type of turbine	Specification of foundation
Vindeby	DK, Baltic / 1991	2-4 m / 1.5 km	11 / Bonus 450	Box construction (Caisson)
Tunø Knob	DK, Baltic / 1995	4-7 m / 5 km	10 / Vestas V39 (2 MW)	Concrete box construction (Caisson) filled with iron ore ⁵⁾
Middelgrunden	DK, Baltic / 2001	3-6 m / 5 km	20 / Bonus 2 MW	Ground plate Ø about 17 m, height 8-11 m, weight 1,800 t ²⁾
Nysted	DK, Baltic / 2003	6-9 m / 10 km	72 / Bonus 2.3 MW	Ground plate Ø 15.5 m, weight about 1,300 t ¹⁾
Lillgrund	S, Baltic / 2007	10 m / 10 km	48 / Siemens 2.3 MW	Ground plate Ø 19 m; cylindrical shaft, weight about 1,500 t ⁶⁾
Met mast Arkona-Becken-SO	D, Baltic / 2007	24 m / 35 km	1 / Met mast (86 m height)	Pre-stressed concrete with reinforced concrete, weight 1,200 t ⁸⁾
Avedore Holme demonstration wind turbine	DK, Baltic / 2009	2 m / some meters (on-shore)	2 / Siemens 7 MW	Solid, cone-shaped ³⁾
Sprogø (Storøbelt)	DK, Baltic / 2009	6-16 m / 10.6 km	7 / Vestas V90 3 MW	Ballasted base trough Ø 20-22 m, cylindrical Shaft, 1,600-1,900 t ⁷⁾
Thornton Bank	B, North Sea / 2009	13-19 m / 27 km	6 / REpower 5MW	Pre-stressed concrete; conic base with cylindrical shaft (Ø 6.5 m), weight 2,700 t ⁷⁾
Rødsand II	DK, Baltic / 2010	6-12 m / 8.8 km	90 / Siemens 7 MW	Hexagonal ground plate, cylindrical shaft, weight 1,400 t ⁴⁾
Pori Offshore 1	F, Baltic / 2010	9 m / 1.2 km	1 / Siemens 2.3 MW	Demonstration site for the steel shell gravity foundation ⁹⁾

¹⁾ THOMSEN et al. (2007)

²⁾ SØRENSEN et al. (2002)

³⁾ <http://www.dongenergy.com/avedore/EN/Pages/index.aspx>

⁴⁾ <http://www.bilfinger.com/en/Profile/Business-Segments/Construction/Making-waves-in-offshore-wind-power>

⁵⁾ http://www.offshorewindenergy.org/ca-owee/indexpages/Activities_and_Prospects.php?file=actpros_p3.php

⁶⁾ http://www.hochtief-construction.com/construction_en/data/pdf/OWF_Lillgrund_engl.pdf

⁷⁾ <http://www.sundogbaelt.dk/uk/menu/csr/environment/sprogo-offshore-wind-farm/wind-turbine-fact-box.img>

⁸⁾ THOMSEN et al. (2007)

⁹⁾ <http://www.strabag-offshore.com/projekte/arkona-becken-suedost/montage-transport-installation.html>

¹⁰⁾ <http://www.lorc.dk/offshore-wind-farms-map/pori-offshore-1>



Figure 50: Gravity base foundations of the OWF *Lillgrund* (source: left VATTENFALL 2008, right: FREISEN 2010)

A foundation type developed by **STRABAG Offshore Wind GmbH** is made of a triangular box of pre-stressed concrete opening to the top and a concrete shaft. This gravity base foundation is specially developed for offshore turbines in the North Sea and Baltic Sea at water depths of up to 55 m. The longest distance of the ground plate is 38.5 m (Figure 51). The shaft ends at the cutting point between turbine and foundation about 20 m above sea level. The weight of the foundation is about 7,000 t. Stones or sand-filled bags serve as scour protection (WAHRMUND 2012).

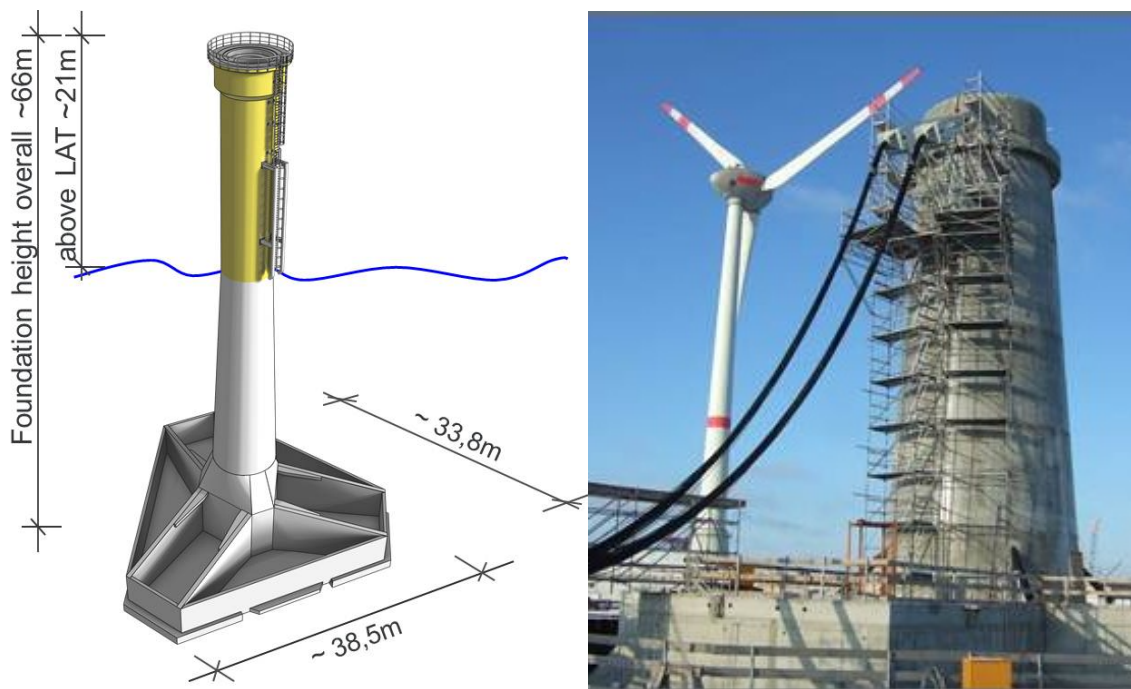

Figure 51: STRABAG-gravity base foundation: Construction details (left), and test foundation scale 1:1 at the factory premises in Cuxhaven (right) (source: WAHRMUND 2012)

The concept for serial production includes the onshore pre-assembly of the turbine and the foundation, which are then shipped to the offshore location by a special ship. During transport, the complex of turbine and foundation hangs upright on cable winches in the middle of the ship. The turbine is placed at the offshore location by means of the cable winch²⁰. The pit is excavated until a load-bearing layer is reached and a plane surface will be produced. After being placed on the ground, the

²⁰ The necessary soil preparations require the relocation of large quantities of sediment. Depending on sediment type and handling of materials, this may induce large turbidity plumes which have to be taken into account when evaluating the ecological impacts of the technique.

foundation's open boxes will be filled with ballast sand from the excavation pit which was stored in the interim on a special ship (HOLGER WAHRMUND, *Strabag Offshore Wind GmbH*, Cuxhaven/Stuttgart, pers. comm.).

The **CraneFree Gravity Foundation** by *Seatower AS*, which is also suitable for larger water depths, is a self-installing gravity base foundation. It does neither require soil preparation nor large installation vessels but only three tugs ([Figure 52](#)). The lower part of the foundation is made of concrete, its upper part of steel. The floatable foundation is towed to the site where the tugs and anchors hold it in place during installation. When the final position is reached, a hydraulic valve is opened in order to let sea water into the foundation by which the structure is lowered gradually to the sea bed. The foundation has steel skirts at the bottom which penetrate into the sediment due to the weight of the foundation. Flowing concrete is injected under the foundation filling up the void underneath. This procedure achieves the full contact between seabed and foundation without dredging and leveling the seabed before installation. The steel skirt in the sediment provides additional stability to the structure (similar to bucket foundations, [chapter 5.5](#)). Consequently, the required weight of the structure is less than in a conventional gravity base foundation. Sand is filled into the hollow chamber of the foundation acting as additional ballast. The final weight of the foundation is between approximately 6,000 and 7,000 t. On a sandy seabed scour protection is installed around the structure to prevent erosion. The eventual removal or decommissioning is done by simply reversing the installation process.

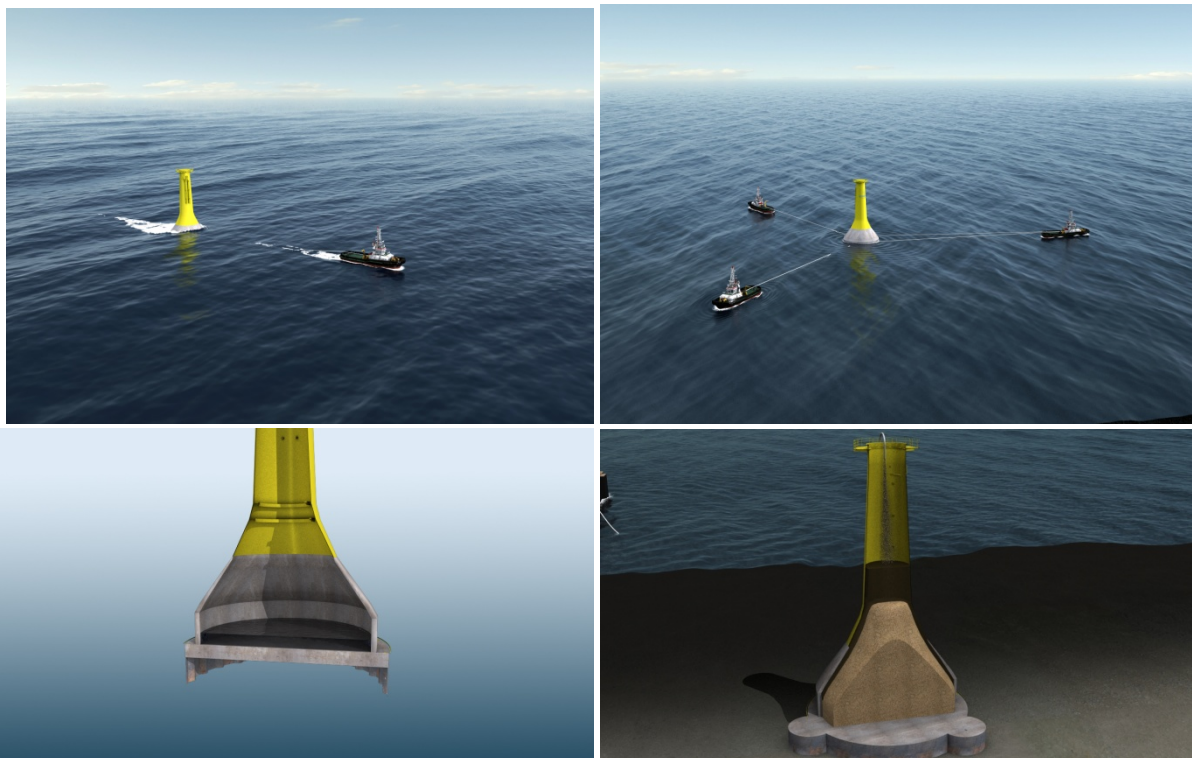

Figure 52: *CraneFree* gravity base foundation developed by *Seatower*. The bottle shaped foundation is towed to the site (upper left), positioned (upper right), flooded in a controlled manner so that no specific barges are required. Steel skirts at the bottom, comparable to a bucket foundation, provide additional stability (lower left). Injection of flowing concrete under the foundation levels uneven ground. Additional weight is gained by filling the foundation with sand (lower right)

5.3.2 Valuation of Gravity Base Foundations

5.3.2.1 Noise Mitigation

No specific sound measurements of the construction of gravity base foundations are available. No impact pile driving is necessary for the placement of the system, hence no impulsive sound is emitted. Apart from ship noise, additional continuous noise emissions are to be expected during the soil preparation by suction hopper dredger (except for the *CraneFree*-concept by *Seatower*). Relevant noise emissions will also be produced by the dynamic positioning systems of the working ships (WAHRMUND 2012). However, it may be assumed that the overall noise level will be lower than for impact piled driving. Hydroacoustic measurements during dredging of a suction hopper dredger showed maximum sound levels of 150 dB (SEL) at 750 m (ISD 2010, cited in WAHRMUND 2012). A direct comparison of the impact of continuous sound on marine organisms to that of impulsive sound is not possible solely based on the sound level. The frequency distribution of the signal is also important, specifically with regard to disturbance. Furthermore, the background noise produced by shipping in the area has to be considered, as habituation to continuous sound is another possible effect.

In case the foundation protrudes beyond sea level, it possibly reduces the operational noise of the turbine as the steel mast is acoustically decoupled from the water body. Measurements of operational noise from the same turbine type (Bonus 2.3 MW) indicated sound levels 12-15 dB higher in the OWF *Nysted* than in *Paludans Flak* (ELMER et al. 2007a). These differences may be attributed to the different foundation types (*Nysted*: concrete gravity base foundation, *Paludans Flak*: monopile)²¹. In *Nysted*, the shaft of the monopile protrudes about 3.5 m beyond sea level (Figure 49), thereby possibly reducing the direct transmission of sound from the tower as, in contrast to the monopile, the tower of the gravity base foundation is acoustically decoupled from the water.

5.3.2.2 Development Status

Gravity base foundations have been used for offshore wind turbines for a long time and can therefore be considered proven technology, at least in shallow water of less than 19 m (OWF *Thornton Bank*). For greater water depths there is virtually no experience with this foundation type. The application of gravity base foundations is planned for offshore wind farms in Germany at water depths of up to 45 m. In the German Bight there are plans to install ten wind turbines on gravity base foundations by *Strabag Offshore Wind GmbH* at a depth of 40 m within the test-field *Albatros* (BSH 2011, TÜV SÜD 2011).

The development of gravity base foundations suitable for offshore wind turbines at greater depths is currently in the pilot stage. Experiments were performed in the small as well as in the large wave channel by *Strabag Offshore Wind GmbH*. Furthermore, a test foundation was built at *Strabag*'s factory premises in Cuxhaven in a 7 m deep excavation pit based in ground water (Figure 51). The soil properties correspond to those of the future wind farm locations. By means of specific load units, experiments were performed to investigate the stability under cyclical loads similar to those at 40 m water depth (STRABAG 2012, HOLGER WAHRMUND, *Strabag Offshore Wind GmbH*, Cuxhaven/Stuttgart, pers. comm.).

²¹ The water depth of 9.5 m at *Nysted* is less than the 20 m at *Paludans Flak*, therefore the sound radiating area is lower. However, under the assumption of uniform sound radiation over the full water column, this would only result in a difference of about 3-4 dB (ELMER et al et al. 2007). Thus, the difference in water depths can only explain part of the observed difference (BETKE & MATUSCHEK 2010).

The facilities for serial production are already planned at Cuxhaven, Germany (WAHRMUND 2012). Other companies such as *Gravitas Offshore Ltd*, a consortium of *Hochtief*, *Costain* and *Arup*, also offer gravity base foundations for offshore wind turbines. In August 2012, the consortium secured funding from British public authorities, which is meant to support further development of *Gravitas* foundations (GRAVITAS 2012). A disadvantage of concrete gravity base foundations is that their costs rise with increasing water depth. RAGHEB (2010) calculated that costs rise proportionally to the square of the water depths²² and postulated that the application of these foundations is economically inefficient at depths of more than 10 m. Despite the lower price of concrete compared to steel, the overall costs of concrete foundations in deep water may not be lower due to the larger masses and the elaborate construction technology required. To what extent serial production, the corresponding engineering and the fact that onshore pre-fabrication will be used will make the technique economically feasible in addition to the already proven applicability remains to be shown. Therefore, a full scale test under offshore conditions is needed to gain experience with production, transport and installation.

According to the company *Seatower* considerable cost advantages can be achieved with their *CraneFree*- gravity base foundations. The concept is cost-optimized by effective serial production, eliminating the need for specialized installation vessels and soil preparation at the site as well as saving material due to the use of a bucket-like steel skirt. A similar installation procedure is normally used for gravity base foundations in the offshore oil and gas business in which the company has long-standing experience. The design is fully developed and has been tested on a model. Currently, the company is looking for partners to conduct a full-scale prototype project.

5.4 Floating Wind Turbines

Various research institutes and companies are developing floating wind turbines based on different types of floating concepts. Most developments aim at making larger depths accessible to wind energy use (such as e.g. the Norwegian, Spanish, and Portuguese coasts, in the Mediterranean sea, off Taiwan, Japan, and the east coast of the US), in which standard fixed foundations are either too expensive or impossible but which lie in proximity to cities or industrial complexes to be supplied with wind energy.

For the Norwegian company *StatoilHydro* floating concepts are already proven technology in the deep water oil and gas business. The *HYWIND* prototype installed in June 2009 off the west coast of Norway (12 km off the island Karmøy at a depth of 220 m) combines known technologies in a new setting (Figure 53). The floating structure, a SPAR buoy, is a ballasted hollow steel cylinder (diameter: 6 m, draft 100 m) attached to the seabed by a three-point mooring spread. This is standard in oil and gas exploration. The concept is suited for water depths of 120 to 700 m. The SPAR buoy has a *Siemens SWT-2.3-82* wind turbine (rotor diameter: 82 m, rated power: 2.3 MW, hub height: 65 m) on top. The prototype was put into operation in 2010. In 2011 it already generated 10.1 GWh of electricity (<http://www.lorc.dk/offshore-wind-farms-map/hywind-demonstration>).

²² According to the formula: $Cost \propto D_{water}^2$ (RAGHEB 2010).

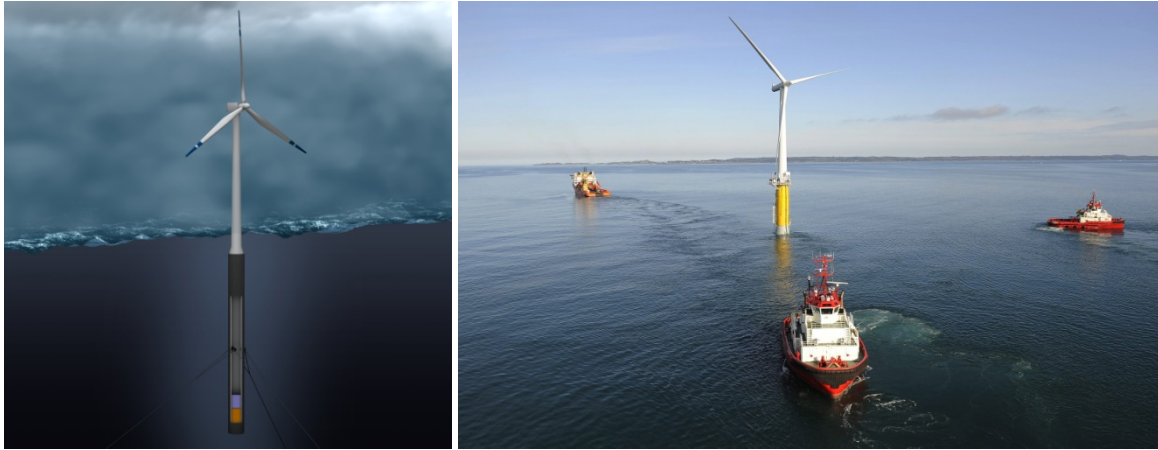

Figure 53: Offshore wind turbine on SPAR buoy in the *HYWIND* project (source: SIEMENS 2009, Øyvind Hagen/Statoil)

The concept of the Norwegian based company **Sway** resembling a giant bobber was engineered for water depths of 80-400 m and coastal distances of 50-60 km (**Figure 54**). It is a tower-like semi-submersible stiffened by vertical steel cables kept under high tension. It has a slim anchor pattern consisting of only one single vertical anchor leg with a suction anchor. In the wind turbine a downwind drive is used and thus the floating foundation acts like a wind vane passively finding the best position to the wind rather than using a yaw system. The companies *Areva* and *Sway* are co-operating in order to adapt the Multibrid M5000 to enable downwind turbine operation. A prototype scaled 1:6 was installed in 2011 off the Norwegian west coast. In early 2012 the prototype was towed to shore and repositioned after repairs of electric components in May 2012. An already approved full-scale prototype of a gearless downwind turbine is projected for 2013 seven kilometres off the island Karmøy off the Norwegian west coast (www.sway.no).



Figure 54: Sway concept and prototype 1:6 (source: www.sway.no)

Between 2007 and 2009 the Dutch company **Blue H**, through its Italian subsidiary *Sky Saver* installed a 75% size prototype of its *Submerged Deepwater Platform* (SDP, based on the *tension leg platform* (TLP) – a proven system in the oil and gas deep water exploration) with a hull draft of 15 m equipped with an 80 kW wind turbine off the coast of southern Italy near Brindisi ([Figure 55](#) top).



Figure 55: Wind turbine on *Blue H* Submerged Deepwater Platform SDP. Top: first prototype tested offshore from 2007 to 2009 (source: *Blue H*, Oosterhout, The Netherlands, www.bluehgroup.com). Bottom: concept of a 5 MW prototype with submergible gravity based anchor weights (Quelle: Nico C. F. BOLLEMAN, *Blue H Engineering BV*, The Netherlands)

The anchor chains of the buoyant semi-submerged platform are held constantly tensioned by means of a counterweight filled with 1,000 t of gravel at a water depth of 113 m (www.bluehgroup.com, [LESSNER 2010](#)). The further development of this floating foundation is the concept of a more economical 5 MW unit suited for water depths from 30 m onwards (draft before tension: approximately 10 m) which is currently engineered by *Blue H Engineering* in the Netherlands. The construction of a full-scale prototype is planned for 2015, its installation for 2016.

Forced by its buoyancy, the semi-submergible will be held in position by submergible gravity based anchor weights connected with parallel synthetic ropes ([Figure 55](#) bottom). Due to the buoyancy force, which is always greater than wind and wave forces, and the reduced wave attack area by the semi-submerged position the system is stabilized. When the system is decommissioned, the anchor

weights can be de-ballasted in order to wet-tow the total unit to the harbour (NICO C. F. BOLLEMAN, *Blue H Engineering BV*, The Netherlands, pers. comm.).

The floating offshore foundation **GICON-SOF** by the German company *GICON* is suited for water depths from approximately 20 m to more than 40 m, which extends the opportunities to use offshore wind energy to many more sites. The technology is also based on the TLP principle of a semi-submersible tethered to the seabed. It is held in position by means of gravity based anchors or hammered or drilled anchor piles (*micropiles*) (Figure 56). Gravity bases have a weight of over 1,000 t and can be wet-towed to the site, connected to the platform by means of ropes and gradually lowered to the sea bed. This anchoring method is suited for all sea bed conditions.

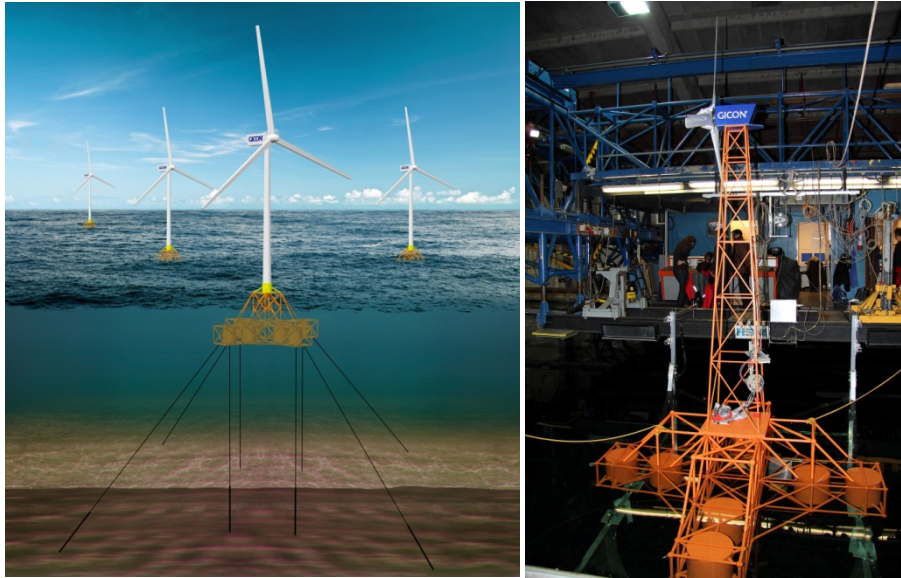

Figure 56: *GICON-SOF* concept and model (source: *GICON GmbH*, Rostock)

A full-scale prototype of a floating foundation **WindFloat** (Figure 57) of the US based company *Principal Power Inc.* with a 2 MW wind turbine was installed in 2011 off the coast of Portugal (5 km off Agucadoura at a depth of 42-53 m). It has already withstood waves of up to 15 m in its first winter. The triangular semi-submersible has a water tank in each of its corner columns. Its draft is approximately 20 m and its weight 6,000 t. It is suited for water depths from 30 m onwards. The columns have patented *water entrapment plates* at their bases acting as stabilisers and thus improving motion and stability performance. One of the columns has a *Vestas V80-2.0 MW* wind turbine on top. For horizontal trimming and flexible reaction to changes in wind loads, ballast water can be pumped between the column tanks. The foundation is anchored by means of four *drag embedded anchors* (PRINCIPLE POWER INC. 2011).

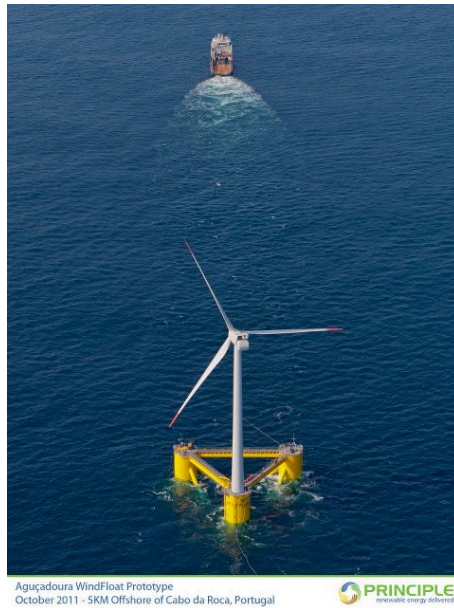

Figure 57: *WindFloat* full scale prototype by the company *Principal Power Inc.* wet towed to the site (source: PRINCIPLE POWER INC. 2011)

The concept of the Norwegian company **WINDSEA A/S** consists of a semi-submersible and offers a cost effective solution using three wind turbines on top of each of the corner columns (WINDSEA 2011). Two turbines operate upwind while one has a downwind drive. The freely rotating platform is self-orientating towards the wind by means of the downwind operating turbine acting as a wind vane (Figure 58). The concept is suitable for water depths of 45-120 m. According to WINDSEA the technology of this heavy weight floating foundation is proven in the offshore business. Tests of a 1:40 model in a wind tunnel and wave basin verified the main principle of the concept and resulted in plans for a full-scale prototype with three wind turbines of a rated power of 3.6 MW (turbine height 71-90 m above sea level, draft 23 m, rotor diameter 104 m) for which the company is currently seeking investors.



Figure 58: WINDSEA concept of two upwind and one downwind operating wind turbines on the same floating foundation, a freely rotating semi-submersible (source: WINDSEA AS)

The project **INFLOW** (INDustrialization setup of a FLoating Offshore Wind turbine) of the French company *Technip*, a developer of subsea oil and gas technology, and further partners also includes a novel design of a 2 MW gearless wind turbine is best matched to the needs of their specific floating foundation. The use of a vertical axis wind turbine results in a low-lying centre of gravity. This is beneficial for the dimensioning and cost of the semi-submersible (Figure 59). Among other advantages, a much lower hull draft (approx. 9 m) is possible compared to standard wind turbines. Also, yaw and

pitch controls can be dispensed. In the course of the predecessor project *VERTIWIND* a similar turbine prototype (scale 1:2, 35 kW) has been installed onshore. The next step towards commercialization is to optimize the existing prototype aiming at the establishment of an offshore test site with 13 floating wind turbines in the Mediterranean Sea near Marseille. This project is funded by the European Commission's Seventh Framework Programme (www.inflow-fp7.eu).



Figure 59: The distinguishing feature of Technip's INFLOW project is the vertical axis wind turbine resulting in a low centre of gravity (source: www.inflow-fp7.eu)

The French consortium of the developer *Nass & Wind* (Lorient), the energy division of *DCNS* (Brest and Lorient), *Ifremer* (Brest), *ENSTA Bretagne* (Brest) and *Groupe Vergnet* (Ormes) is developing the **WINFLO** concept (Figure 60), a semi-submersible construction with a two-blade wind turbine. A 1 MW demonstration project will be installed off the coast of Brittany in 2013 in order to conduct accompanying research for 12-18 months (www.nassetwind.com).



Figure 60: A two-blade wind turbine on a semi-submersible construction is realized in the WINFLO concept. Left: an artist's view of a WINFLO windfarm, right: model test in a wave tank in October 2011 (Copyright: WINFLO 2011)

The **Floating Power Plant Poseidon 37** (a 1:3 scaled testing facility) uses a hybrid system that can harvest wave and wind energy (Figure 61, www.floatingpowerplant.com). The platform contains ten wave energy absorbers (rated power of 50 kW) and represents the basis for three wind turbines (rated power of 11 kW). The first 37 m wide prototype has been installed for three test periods (2008, 2012, third test period commenced in 2012) off the north coast of the Danish island of Lolland in the Baltic Sea and connected to the grid. The next steps will be an 80 m wide prototype off the coast of France or the UK in 2015 and a 110 m wide version off the Oregon coast between 2016 and 2017. In the future, the final version of a 150 m wide platform with wave absorbers with a rated power of 6 MW is supposed to carry a 6-7 MW wind turbine or three 1.5 MW wind turbines (ANDERS KØHLER, *Floating Power Plant AS*, Copenhagen, pers. comm.).

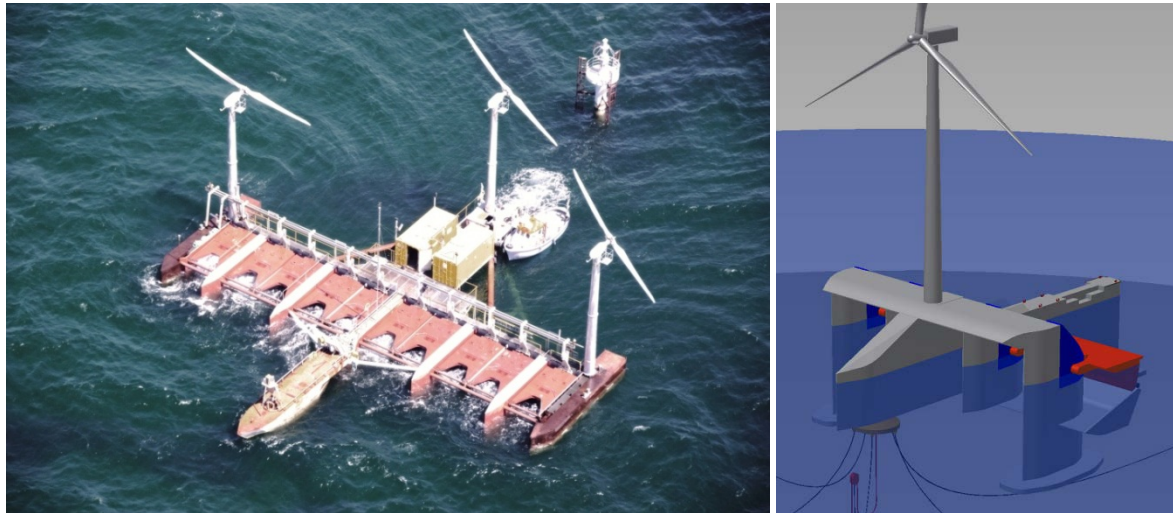

Figure 61: *Poseidon 37*, a prototype of a *Floating Power Plant* during offshore tests in the Danish Baltic Sea (left) and concept for a *Poseidon 80* platform (right) (source: *Floating Power Plant AS*, Copenhagen)

5.4.1 Valuation of Floating Wind Turbines

The number of different floating concepts reflects the obviously high importance of this foundation type for the offshore wind energy industry. Because nearly all coastal areas, independent of water depth, are accessible to this technology, the market potential is assumed to be about ten times higher for floating applications than for fixed foundations (NICO C. F. BOLLEMAN, *Blue H Engineering BV*, The Netherlands, pers. comm.). Due to this anticipated market potential several large, financially strong oil and gas and defence companies are investing in such plans. High funding amounts are directed into research and development. One advantage of floating foundations compared to standard fixed foundations is that the installation and repair can be carried out in a dockyard or port independent of weather and sea state. This also results in cost advantages. Developers anticipate lower environmental impacts compared to other foundation types and fewer conflicts with coastal communities and tourism due to the installation at greater distances from the coast. In addition, at greater distances from the coast, the wind is stronger and less turbulent and thus can generate more power.

Since investment costs for fixed foundations increase considerably at water depths of more than approximately 30-40 m, the floating foundation is attractive from this depth onwards (LESSNER 2010). However, in shallower water, the competitiveness of floating foundations is debatable due to the high steel and construction costs and the more complex and expensive mooring in shallow tidal waters with stronger currents.

A precondition for the approval of all floating wind turbines is the proof of a safe anchorage in order to prevent risks or obstacles for marine traffic. According to initial studies, mooring in shallow waters (below 60 m) seems to be no trivial issue due to the dynamic of anchor lines (LOUIS QUESNEL, *Fraunhofer-Institute for Wind Energy and Energy System Technology IWES*, Bremerhaven, pers. comm.). The retightening of anchor chains is an important aspect to be addressed in shallow waters with a high tidal range and strong horizontal forces from currents such as in the North Sea. Particular challenges have to be met in TLP concepts because the mooring has to be kept under constant tension. Also, due to bottom currents, there is the need for scour protection around the anchors.

Another general challenge in floating foundations results from their motion. As soon as the floating foundation allows pitching and rolling, the wind turbine generates less power and the blades frequently operate inefficiently. The need for additional blade control functions may prove costly. An advantage of TLP concepts is that they are very stable floaters due to the constant tension of their moorings and thus do not require compensation functions. Some semi-submersible floating foundations have stabilizing features such as water entrapment plates (*WindFloat*) and trimming options for their water tanks.

Whether TLP concepts such as *Blue H* and *GICON-SOF* or semi-submersible foundations not tethered to the seabed such as *WindFloat*, *WINDSEA*, *INFLOW* and *WINFLO* can compete with standard fixed foundations in shallow water in the German EEZ is thus a matter of finding cost competitive solutions for the problems outlined above. A special case is the hybrid *Floating Power Plant* in which wave energy absorbers attached to the semi-submersible foundation are used for additional power generation, thereby having a positive effect on the cost competitiveness of the floating structure. Due to their large draft, SPAR buoy concepts such as *HYWIND* and *Sway* are not suited for the German EEZ with water depths of 30 to 40 m.

5.4.1.1 Noise Mitigation

Since floating concepts allow for a high level of pre-fabrication onshore, the underwater noise during installation is limited to transport and the anchoring process. From the noise perspective the anchorage is of special importance. In case of impact pile driving to be used for the anchorage, no fundamental noise reduction compared to standard fixed foundations is expected. For the use of gravity base anchors, noise emissions are similar to gravity base foundations ([chapter 5.3.2.1](#)) with the exception that they are smaller and thus easier to install. Noise emissions of the anchoring process with suction anchors are comparable to those arising from the installation of bucket foundations ([chapter 5.5.2.1](#)). Another option presented by *GICON* is to use drilled micropiles. However, in order to avoid making too many development steps at a time, the anchors of the *GICON-SOF* demonstration unit will probably be piles driven by impact hammers.

To date, noise emissions during the operation of floating wind turbines have not been compared to those of turbines resting on standard fixed foundations. Noise radiation from the turbine or waves within the floating structure is much more complicated than in monopiles and thus, no well-founded prognosis is possible here.

5.4.1.2 Development Status

To date, a number of different floating foundation concepts are available ([Table 7](#)). Some of these are based on proven technologies such as wind turbines or floats already available on the market. Other concepts are completely new developments. Obviously, there are differences in the application range: The mere length of some foundations limits their application to deep water (e.g. *HYWIND*, *Sway*, see above) with the result that they are not suitable for application in the German EEZ. In these waters, only pontoon-like structures or shallow semi-submersibles represent possible solutions.

To date, the projects *GICON-SOF*, *INFLOW* and *WINDSEA* are in the experimental stage. The pilot stage has been reached by *WindFloat* with a full-scale offshore test as well as *Poseidon 37*, *Sway*, and *Blue H*, all with downsized offshore prototypes, and *WINFLO* with a prototype under construction. *Blue H* has suspended the plans for a full-scale 2 MW prototype which was already under construction. Due to changed market demands the company adapted their plans to a 5 MW unit. The pilot phase of *HYWIND* (2.3 MW) and a two-year accompanying research programme have been successfully completed and a high energy yield achieved by the pilot installation has been published. The next milestone will be to increase cost competitiveness in order to make the step from development to industrialization. Hence, small pilot wind farms of three to five wind turbines are currently projected for which sites in the UK and the US are currently being sought.

Table 7: Development state of various projects using floating foundations

Project	Current state of development	Prototype planned for
HYWIND	Full-scale-test in Norway completed	2-year accompanying re-search programme 2009-2011
Sway	Nearshore test with 1:6 downsized prototype, full-scale prototype approved by the government	Full-scale prototype likely 2013
Blue H	Tests of 75 % model of the original 2 MW concept completed.	2008
Blue H Engineering	5MW floating system with commercially available turbine in concept stage.	2016
GICON-SOF	Wave tank tests completed, implementation phase of a full-scale demonstration unit off the German Baltic Sea coast	2014
WindFloat	Full-scale prototype with <i>Vestas V80</i> installed off the Portuguese coast in 2011	Testing since 2011, plans for the installation of further prototypes at the same site
WINDSEA	Tests of a 1:40 model in wind canal and wave tank completed	Investors sought
INFLOW	Onshore demonstration at reduced size (scale 1:2, rated power: 35 kW)	2013
WINFLO	Model tests ongoing (until approximately 2012), prototype under construction	2013
Poseidon 37	Offshore tests of down-scaled prototype (width: 37 m, three wind turbines of 11 kW rated power) including wave energy absorbers.	Larger prototype (width: 80 m) projected for 2014/2015, 110 m wide prototype for 2016/2017

SPAR buoys (*HYWIND* and *Sway*) and TLP based floating foundations (*Blue H*) are already proven technology in the offshore oil and gas business and are often used in deep waters. Platforms are market available. However, dynamic loads of the construction are different in shallow waters and when the structure is equipped with a wind turbine. Thus, further development and full scale demonstrations are needed for OWF applications.

The *German Federal Ministry of Economics and Technology* (BMWi) funded the development of a planning tool for technical, ecological and economic design fundamentals for the *GICON-SOF* in mod-

ular design²³ which was completed in 2012 (GICON 2011). This tool has been applied to an example of a possible site for a currently planned full-scale demonstration unit. The aim of this project was to develop a complete solution for floating wind turbines in North and Baltic Sea applications as well as to verify the suitability for the North Atlantic. Based on a number of pending patents by GICON, modular solutions are available. These are supposed to be optimized and can be adapted to a variety of conditions. Computer simulations as well as model tests (scales 1:25 and 1:40) in a wave and ice canal are completed. GICON and the *Institute of Applied Ecosystem Research (IfAÖ)* are projecting a full-scale demonstration unit off the German Baltic Sea coast which is partly funded by the federal state of Mecklenburg-Western Pomerania. This project would mark the beginning of a pilot stage. The functional demonstrator will likely be realized with a wind turbine of a rated power between 2 and 4 MW (BURKHARD SCHULDT, GICON Rostock, pers. comm.).

5.5 Bucket Foundations (suction bucket / suction caisson)

Bucket foundations are possible solutions for anchoring platforms and wind turbines. Specific versions are the three-legged jackets with bucket foundations of the companies *Overdick GmbH & Co. KG* (Figure 62) and *SPT Offshore* (Figure 63).

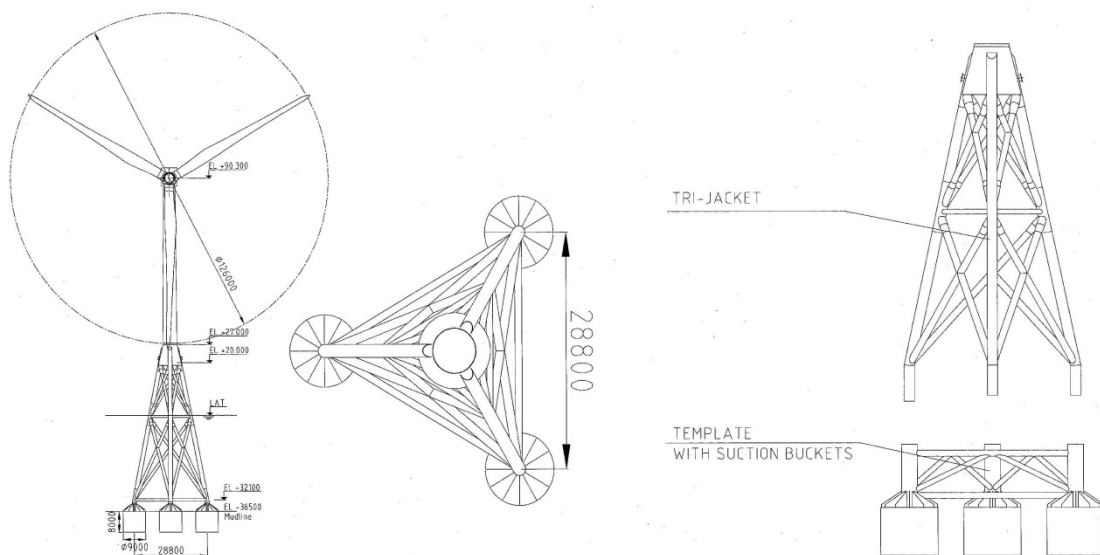

Figure 62: Prototype of a three-legged jacket design with bucket foundations (source: *Overdick GmbH & Co. KG*, Hamburg, Germany)

²³ Project partners were GICON, University of Rostock, TU Bergakademie Freiberg, WPC Windpower Construction GmbH, Jähnnig GmbH, FUGRO GmbH, VBW Survey Office Weigt GmbH, WPD GmbH and GLC Glücksburg Consulting AG.



Figure 63: Asymmetric three-legged jacket design with bucket foundations (source: *SPT Offshore*, Woerden, The Netherlands)

5.5.1 Experience with Bucket Foundations

In October 2002, a 3 MW wind turbine *Vestas V90* (hub height 89 m) with a single bucket foundation (*monopod*) was successfully installed in a polder (consisting of natural marine sediments) near **Fredrikshavn**, Denmark. The welded steel construction of the bucket foundation consists of a central monopile connected to the caisson by means of stiffeners ([Figure 64](#)). The diameter of the bucket is 12 m and its height 6 m. The caisson has been completely sucked into the ground. The total weight of the prototype is 135 t (100 t less than a monopile foundation at the same location). Soil preparations before installation included excavation to NN-4.4 m. Also, a scour protection was deemed necessary (IBSEN et al. 2005).

A bucket foundation is – comparable to an upside-down bucket – a large steel caisson which is founded in the seabed by suction pumps. After the bucket is lowered to the ground it penetrates into the sediment due to its own weight. The water is pumped out of the cavity underneath the caisson. The resulting vacuum in combination with the additional force of the hydrostatic pressure makes the caisson penetrate into the seabed up to its final embedment depth. If the bucket for any reason (such as an unforeseen large stone) cannot be founded at the first attempt, the whole operation is reversible. The caisson can be lifted by pumping water into its cavity and subsequently it may be repositioned. The stability of the bucket foundation results from a combination of soil resistance, ground and hydrostatic pressures and vertical bearing capacity (IBSEN et al. 2005). The water depth is a critical factor for the dimensioning of the bucket. Below a depth of approximately 30 m, the hydrostatic pressure is too low for a bucket installation (EKKEHARD OVERDICK, *Overdick GmbH & Co.KG*, Hamburg, pers. comm.).

In April 2005, *ENERCON* planned to install a 4.5 MW E-112 wind turbine on a bucket foundation near-shore at 4 m depth at Hooksiel near Wilhelmshaven (caisson diameter 16 m, height 15 m) (LEBLANC 2009). However, during the build-up of the vacuum the caisson deformed. As a consequence, the operation was suspended. According to IBSEN & NIELSEN (2007) the deformation may have been caused by a collision with the heavy load pontoon *Giant 4* during the installation process (LEBLANC

2009). The steel was dented inside by 8 cm and the caisson distorted during suction into the seabed (Figure 65) (IBSEN & NIELSEN 2007).

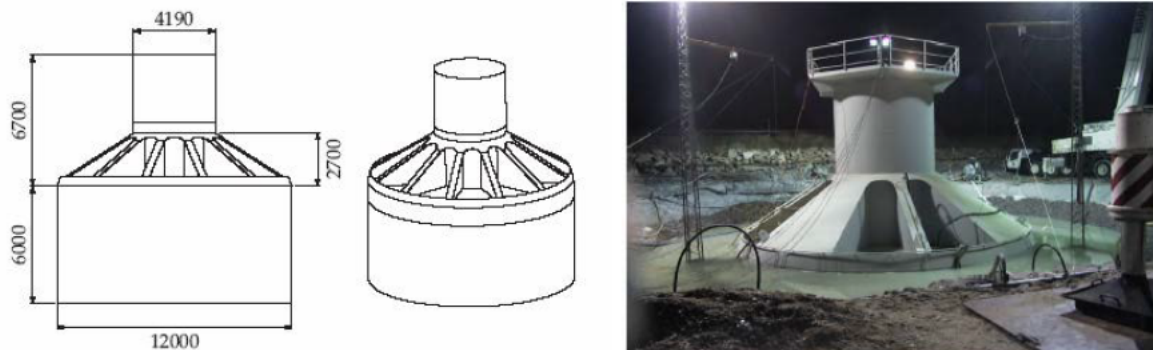

Figure 64: Prototype of the bucket foundation at Frederikshavn with dimensions given in mm (source: IBSEN et al. 2005)



Figure 65: Deformed bucket foundation of an *Enercon E 112* wind turbine near Hooksiel (source: IBSEN & NIELSEN 2007)

In March 2009, the prototype of a monopod was successfully installed in the OWF *Horns Rev 2*, Denmark (Figure 66, Table 8). The foundation carries a met mast which can be detached from the seabed by reversing the installation process. The installation was carried out by *Nearshore LAB A/S*, a subsidiary of *DONG Energy* (LEBLANC et al. 2009). The foundation was constructed by the Danish company *Bladt Industries A/S*, which also was the manufacturer of the *Enercon* foundation intended for the Hooksiel prototype.

Bucket foundations are commonly used in the offshore oil and gas industry, particularly for the foundation of deep water platforms where suction anchors are used as a cost-competitive method *i.a.* for tension leg platforms. These are floating platforms held in position by means of vertical steel cables under strong tension. Anchor piles (cylindrical steel constructions which are open at the bottom and closed at the top) are sucked into the seabed by creating a vacuum inside. In deep water the high hydrostatic pressure is beneficial for this process.



Figure 66: Bucket foundation of a mobile met mast for the OWF *Horns Rev 2* during erection in the port (source: LEBLANC et al. 2009)

Table 8: Basic dimensions of the bucket foundation of the met-mast at the OWF *Horns Rev 2* (source: LEBLANC et al. 2009)

Height of the metmast	38 m
Weight	165 t
Height of the skirt	6 m
Caisson diameter	12 m



Figure 67: Jacket for offshore oil platform with suction buckets (source: *SPT Offshore*, Woerden, The Netherlands, www.suctionpile.com)

Meanwhile, this type of foundation ([Figure 67](#)) has frequently been installed in shallower water. E.g. the company *Overdick GmbH & Co KG* has successfully founded platforms on jackets using buckets at water depths between 50 m and 70 m ([Figure 68](#)). These can either be carried by a super barge or wet-towed to the offshore site as MOAB (*Mobile Application Barge*). In the North Sea, for instance, a gas compression platform was installed in the Trent field using this technology. Further examples are production platforms off Western Africa or Malaysia (EKKEHARD OVERDICK, *Overdick GmbH & Co.KG*, Hamburg, pers. comm.; OVERDICK 2012a).

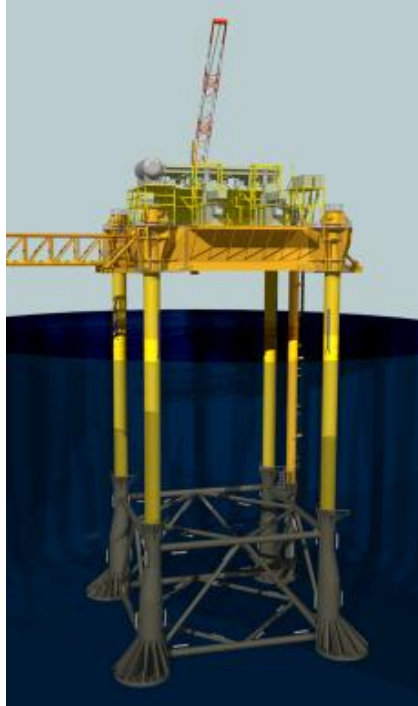

Figure 68: Platform founded on buckets for water depths of 50 m and deeper (source: *Overdick GmbH & Co. KG, Hamburg*)

5.5.2 Valuation of Bucket Foundations

Bucket foundations are not applicable to all soil types. Homogenous water-saturated sediments with moderate grain size are a prerequisite, whereas for sandy soils a larger pump output is required due to greater porosity compared to silty sediments. Large stones or erratic blocks can cause problems. However, as the process is reversible, the foundation can be re-lifted and reinstalled at a neighbouring site.

As outlined above, various foundation concepts based on buckets exist, e.g. monopods or jackets with multiple buckets. These differ with respect to the distribution of static, dynamic and cyclic loads. Static loads are the main component in platforms (e.g. in the offshore oil and gas industry), whereas in wind turbines static loads are smaller, but particularly vibrations of the turbine or wind loads have to be absorbed (wave and current loads occur in both applications). As a consequence, our valuation differs according to the application:

Platform-Concepts: The foundation of multiple-legged platforms is common practice in the oil and gas sector. In an example in the North Sea, scouring could be avoided using perforated steel partitions on top of the buckets in order to break the currents (EKKEHARD OVERDICK, *Overdick GmbH & Co. KG*; Hamburg, pers. comm.). This innovative and cost-efficient solution renders an additional scour protection around the bucket unnecessary. Under economic aspects, the separation of the anchoring structure from the supporting structure in a modular system is beneficial because it enables serial production and offers the possibility for decoupling the mooring of the bucket-carrying bottom section from the installation of the platform ([Figure 68](#)) (EKKEHARD OVERDICK, *Overdick GmbH & Co. KG*; Hamburg, pers. comm.).

Wind turbine Concepts: Currently it is unclear if and to what extent the mechanical resistance and stability of bucket foundations is impacted by the influence of cyclical loads (vibrations) over the long-term. However, due to their large diameter, bucket foundations are more resistant to specific lateral loads than monopiles (SUKUMARAN, no publication year given). If the suction effect of the soil fails, the construction will become unstable. Large lateral loads typical for offshore wind turbines in

deep water are more difficult to absorb with a small embedment depth in buckets compared to standard deep foundations such as monopiles, jackets, and tripods (ABDEL-RAHMAN & ACHMUS 2005). This is especially true for monopod concepts. The installation of monopods is much more prone to errors than in other foundations. An even penetration into the seabed is evident to guarantee an upright position of the supporting structure. A successful example is the monopod in Frederikshavn, Denmark. However, the collapsing of the *Enercon* bucket near Hooksiel illustrates the difficulties of this foundation technology. The installation of the monopod met mast at the OWF *Horns Rev 2*, Denmark, was accompanied by desktop studies by *DONG Energy* in order to examine the potential of bucket foundations. These resulted in the conclusion that there are still significant technological challenges associated to this foundation type. Essential concerns relate to the following aspects (CHRISTIAN LEBLANC THILSTED, *DONG Energy Renewables*, Gentofte/DK, pers. comm.):

- **Structural problems:** The larger the dimensions of bucket foundations are, the greater is the risk of deformation because the wall thickness decreases in relation to its size. This raises concerns of technical failure of the foundation during installation.
- **Offshore installation:** The anchoring of a bucket foundation is problematic because for various reasons the installation process can fail before final penetration depth is reached. This happened during the installation of the *Horns Rev 2* prototype only 0.6 m before reaching full penetration depth.

It is essential for the bucket foundation concept to address and overcome these problems. After the installation at the OWF *Horns Rev 2* and finalisation of further desktop studies, *DONG Energy* decided not to pursue this foundation concept any longer although significant investments had already been made.

A different valuation is needed for structures founded on multiple buckets. In contrast to monopod foundations in which an extreme point load can result in the collapse or detachment of the bucket, the foundation on jackets with three or four buckets is more promising from a technological perspective. The use of multiple buckets leads to reduced bucket sizes compared to a monopod. The interconnected buckets have to be sucked into the seabed simultaneously. Repositioning is possible in reverse mode if in the first step full penetration cannot be achieved. The system stabilizes itself, which results in a high load-bearing strength. In order to absorb the high vibration loads from the turbine a greater base frame may be needed compared to platform concepts dealing with mainly static loads. However, this increases material requirements, which affects the cost efficiency.

5.5.2.1 Noise Mitigation

For the installation process electric underwater suction pumps which are supplied by Diesel generators are needed. From the underwater noise perspective, the noise emissions of the suction pumps are of basic interest. However, no sound measurements are known. During installation of the *Horns Rev 2* monopod no sound measurements were made either, but reportedly emissions were low and mainly derived from the Diesel generator on the deck of the installation vessel (CHRISTIAN LEBLANC THILSTED, *DONG Energy Renewables*, Gentofte/DK, pers. comm.). The suction process is short and only takes 4-5 hours (EKKEHARD OVERDICK, *Overdick GmbH & Co.KG*, Hamburg, pers. comm.).

5.5.2.2 Development Status

Bucket foundations are already proven technology in oil and gas platforms under suitable soil conditions and water depths (see above). With respect to the loads acting, the purpose of a platform (e.g. gas platform, converter platform) founded on three- or four-legged jackets does not matter. Experiences with static loads on jackets with bucket foundations is definitely positive (EKKEHARD OVERDICK,

Overdick GmbH & Co.KG, Hamburg, pers. comm.). The first converter platform to be installed on buckets is projected for 2013 at the OWF *Global Tech 1*. The weight of the platform is approximately 9,000 t. The supporting structure has four buckets of 11 m diameter and a penetration depth of 9 m. Each bucket weighs 800 t. A similar platform is to be installed at the OWF *Veja Mate* (OVERDICK 2012b).

Past experience was channelled into the concepts of both companies, *Overdick GmbH & Co. KG* and *SPT Offshore*, for offshore wind turbines supported by three-legged jackets with bucket foundations (Figure 62, Figure 63). It is beneficial that this foundation type has experienced widespread use in various commercial applications of numerous offshore suppliers and thus market availability is given.

The reason for the asymmetric three-legged construction (*SIWT, self-installing wind turbine*) engineered by *SPT Offshore* is the specific installation method of fully prefabricated wind turbines (one can be stacked exactly inside another, it can be fixed to the corner of an installation barge). It offers advantages in manufacturing, storage, and installation (SNIECKUS 2011). A specific SIWT installation vessel would cost only a quarter of the estimated price for a large jack-up barge. Further economies can be achieved by the short offshore installation time. *SPT Offshore* assumes an installation time for a wind turbine of the 5 to 10 MW class of only 72 hours. A fully pre-installed wind turbine for a water depth of 45 m would weigh approximately 3,500 t (including approx. 1,000 t of concrete²⁴ built into the two corner suction piles to reduce tensile loads on the supporting structure). The three-legged jacket braces out 35 m from the corner monopile in both directions. The diameter of the suction piles could be 2.5 m depending on the soil type. The SIWT is intended for use at water depths of 30-60 m. Due to effects of cyclical loads silty soils may not be resistant enough for the SIWT. However, the effects of high vibration loads in jackets with multiple buckets are as yet unclear. Further research on a prototype addressing this aspect is needed. After successful model tests, the company *SPT Offshore* has currently completed the detailed design for a demonstration project. A full-scale SIWT within an OWF in the German Bight is currently being negotiated with a potential client (MARK RIEMERS, *SPT Offshore*, Woerden, The Netherlands, pers. comm.).

Overdick GmbH & Co. KG is currently putting much effort into progressing a different three-legged jacket design. For this purpose, they initiated a research project with several partners (chapter 6). For the manufacturing of a prototype an overall duration of less than two years is expected, nine months for engineering and one year for the production. The main focus is the economic optimization with respect to the size of the base frame and material requirement (EKKEHARD OVERDICK, *Overdick GmbH & Co.KG*, Hamburg, pers. comm.).

²⁴ Accordingly, these are hybrid gravity-base foundation suction piles

6 Current German Research Projects

Currently the *German Federal Ministry for the Environment (BMU)* provides funding for the following research projects aiming at noise mitigation and alternative foundation concepts. For most ongoing projects no provisional results are known. Final reports of already completed projects are available in the *Technical Information Library* of the *University of Hannover* (<http://www.tib.uni-hannover.de/>) and can easily be searched by their *FKZ* number.

In the ongoing research project **Hydroschall-OFF BWII** (Trials of a Large Bubble Curtain at *Borkum West II*) the large bubble curtain was tested during construction of the OWF *Borkum West II*, accompanied by sound measurements of different configurations. The data are currently under analysis (FKZ 0325309A/B/C, <http://www.hydroschall.de>; leadership: *BioConsult-SH GmbH & Co KG*; project partners: *Hydrotechnik Lübeck GmbH* and *ITAP GmbH*).

In the project **Hydroschall-OFF BO1** (Trials of a Small Bubble Curtain at *BARD Offshore 1*) a small bubble curtain with vertical pipes is being developed and optimised. The project is carried out in the framework of the construction of the OWF *BARD Offshore 1* (FKZ 0325334A/B/C/G, leadership: *BARD Engineering GmbH*; project partners: *BARD Building GmbH*, *CSC GmbH*, *MENCK GmbH*).

In the project **VNF** (Validation of a determination method for offshore wind turbine surface foundations subject to cyclically recurring stresses based on measurement data in a large-scale test) improved soil mechanical models for the load bearing characteristics and the dimensioning of offshore surface foundations are to be developed. This project is based on the results of its already completed predecessor project (FKZ 0325175) "Description of the soil dynamics at offshore wind turbine surface foundations subject to cyclically recurring stresses by means of full scale tests". (FKZ 0325405A/B, leadership: *Karlsruhe Institute of Technology (KIT)*; project partner: *Ed. Züblin AG*).

In the project **CPT** (Investigation technology for offshore gravity based foundations) feasible exploration and evaluation methods for construction sites for the preparation of the construction of offshore wind turbine surface foundations are to be developed. The influence of deposit density of sandy strata in the North Sea on the dimensioning is supposed to be factored in already during seabed exploration (FKZ 025407A/B/C, leadership: *FhG-IWES*; project partners: *University of Bremen*, *STRABAG Offshore Wind GmbH*).

In the project **HyproWind** (Realistic hydrosound scenarios for the construction of offshore wind farms in the German North Sea based on forecast models and monitoring) *i.a.* standardized noise charts are to be developed under consideration of possible temporal overlap of multiple construction activities in the North Sea. Another component is the development of an improved forecast tool (FKZ 0325212, <http://www.isd.uni-hannover.de/232.html>, *Leibniz University of Hannover*).

In the research project **BORA** (Predicting underwater noise due to offshore pile driving), profound numeric calculation models for the sound development during offshore piling and models of the sound transmission into water and soil are currently under development. The aim is to enable predictions of the resulting underwater noise as well as the sound attenuation due to possible noise mitigation methods before the beginning of the actual construction activities. This would enable the prior optimisation with respect to underwater noise. For the purpose of validation three extensive offshore measurement campaigns are to be performed at different sites. In September 2012 the first measurement campaign took place in the course of construction activities for the OWF *BARD-Offshore 1*. A further aim of the project is the development of a software based "expert system", which will enable third-party users such as approving and nature conservation authorities, certifiers and biologists to calculate basic noise predictions even without detailed knowledge in numerical simulation (FKZ 0325421A/B/C, <http://www.bora.mub.tu-harburg.de/>).

An ongoing three-year research project (2011-2014) aims at testing and optimization of Hydro Sound Dampers as a noise mitigation method. After tests of a first prototype of an *HSD* system in the framework of the *ESRa* project (FKZ 0325307) in mid 2011, a technically improved system was developed and tested in August 2012 in the course of the construction of the OWF *London Array* under real offshore conditions. (FKZ 0325365, project partners: *Technical University of Braunschweig, Aarsleff* and *Bilfinger & Berger*).

A further research project has the title **WindBucket** (Suction bucket foundations as innovative and construction noise reducing concept for offshore wind energy plants). It aims at proving the stability of bucket foundations as appropriate foundation for offshore wind energy plants. A special emphasis is put on the load-bearing characteristics of this foundation method under cyclical loads (FKZ 0325406A/B/C, project partners: *IWES/Fraunhofer Society, Overdick GmbH & Co. KG, Leibniz University of Hannover*).

Fraunhofer IWES is coordinating the current research project **HiPRWind** (*High Power, High Reliability Offshore Wind Technology*) of 19 project partners which is funded by the European Commission with a term of five years until 2015. The aim of this enabling research is the installation and at least two years of operation of a 1.5 MW demonstration wind power plant on a semi-submersible under toughest environmental conditions. From performance measurement data of the prototype (downscaled by approximately 1:10 compared to anticipated future size of commercial floating wind power plants) conclusions should be drawn for the development of such plants. The *HiPRWind* design as a simple and inexpensive research tool is supposed to lay the foundation for the further development of efficient solutions for serial production and installation. Research includes the floating structure, moorings, grid connection, operations control and advanced rotor concepts. The wind turbine will be delivered by the project partner *Acciona*. The final engineering design of the floating foundation was completed in May 2012. The prototype is intended to be installed in 2013 off the Atlantic coast near Bilbao at a water depth of about 100 m (www.hyperwind.eu).

7 Future Needs for Research

The present study describes the potential for noise mitigation and the state of development for various noise mitigation measures for impact pile driving ([chapter 4](#)) and alternative foundation methods ([chapter 5](#)). It is apparent that there are still knowledge gaps with respect to certain aspects which are partly being filled by results of current research projects. Here, we summarize some of the open questions and essential aspects which must be further investigated. However, questions routinely considered during a standard development process are not mentioned here. All methods still have the potential for improvement with respect to their effectiveness, handling and economic efficiency, which need not be mentioned explicitly here.

Noise Mitigation Measures

The best-studied mitigation measure for underwater piling noise is probably the bubble curtain in its various applications. A crucial aspect for future offshore applications is to determine limiting factors (such as the significant wave height up to which the bubble curtain can satisfy the specific requirements). Because installation work and noise mitigation technique are situated on different platforms, it is possible that increasingly large jack-up vessels enable the installation at larger wave heights which cannot be compensated for by the bubble curtain operating vessel which may then be limiting for the overall installation process. It seems that compressors for offshore use or bubble curtain operating vessels must be improved with respect to this issue.

The acoustical improvement of the piling process is of great interest due to the capability of being combined with methods which shield the noise radiating from the pile, such as bubble curtains, pile sleeves, *HSD* or cofferdams. For large monopiles this additional noise mitigation could be critical to comply with the noise limit mandatory in the German EEZ. Research needs can be identified with regard to extending the use of piling cushions (routinely used for small pile diameters) and adaptation to larger piles ([chapter 4.6.1](#)). Especially aspects of the durability of various cushion block materials and dissipation of resulting heat under closed anvils must be addressed.

Since in noise shielding methods such as bubble curtains, pile sleeves, *HSD* or cofferdams noise radiation in the seabed and coupling of this noise to the water body may limit the effectiveness of the mitigation method (depending on the soil type) another research need is to investigate how to minimize the transfer into the water body. *HSD* elements may provide a solution for this because *HSD* nets can be spread out along the bottom. Calculation and forecast models for the soil influence are already under development in the research project *BORA* ([chapter 6](#)).

A general need is comparative noise measurements with and without mitigation. A comparison of the protected pile with a forecast as a substitute always constitutes a potential source of error.

Low-Noise Foundations

With low-noise foundations for offshore wind turbines some actors are breaking new ground, which naturally provokes scepticism in others. A foundation method may be well-thought-out, yet it will not be applied as long as it is unproven that it is as stable as a standard deep foundation. This regards notably the vibratory pile driving, drilled foundations, buckets for wind power plants and mooring methods for shallow water floating foundations. Some providers of such alternative foundation methods are already conducting respective investigations. However, fundamental research is also needed.

8 Conclusions and Perspectives

Development since Preparation of the First Report (July 2011)

Since the preparation of the first report (only available in German) there have been considerable further developments in noise mitigation technologies and progress in scientific investigations of these technologies. The significant noise mitigation levels of double bubble curtains and pile sleeves in the framework of commercial projects and of cofferdams at least in a pilot study give reason to expect that in the future the German 160 dB threshold level can be met even with large monopiles.

Also, the development of alternative low-noise foundations has made good progress since then. Many projects already mentioned in the first version of the report have been further developed. Pilot plants are under development or awaiting their installation shortly. However, other projects are behind their schedule as outlined in the first report. It cannot be stated here whether they were too ambitious or whether fundamental technical problems were faced or funding was not secured. But one thing is clear: major effort is needed to establish these alternatives on the market equally alongside standard driven deep foundations.

In various conferences and meetings since 2011 it has been shown that in Germany the industry no longer questions the mandatory noise limit and also that most nature conservation organisations consider it adequate. However, the dual threshold value of 160 dB (SEL)/190 dB (peak-to-peak) at a distance of 750 m aims primarily at avoiding injury or hearing damage in marine mammals. Due to the cumulative effects of multiple sound pulses it is possible that in the future the threshold value has to be adapted to progress in research, more likely to lower values than to higher ones. Furthermore, minimising disturbance may play an increasing role in the light of already existing European legislation (e. g., EU Habitats Directive and Marine Strategy Framework Directive) (MERCK 2012). Also, the protection of fish against negative impact resulting from piling noise may come into the focus in the future, especially because fish cannot be scared away from the danger zone by pingers or ramp-up procedures (JOHN STADLER, *NOAA Fisheries*, Portland USA, pers. comm.). The importance of applying effective noise mitigation measures or low-noise foundations will probably increase in the future.

A main aspect in the use of noise mitigation technologies is the integration into the construction process. In this respect, technical, temporal and safety aspects are of importance. Possible delays in the construction process can be caused especially by noise mitigation measures which are taken in the direct vicinity of the pile. Exact forecasts of the prolongation of the construction time are impossible because installation time will improve with experience. Further, technical solutions aiming at universal applicability are still under development. Currently, only the big bubble curtain allows the pre-installation of the noise mitigation technology prior to positioning the jack-up vessel and thus without any influence on construction time. Noise mitigation technologies such as the collapsible telescopic cofferdam or pile-in-pipe piling, which are part of the installation process but are not available yet, may in future give the opportunity to mitigate noise without prolongation of the installation time. The acoustical improvement of the piling process probably also does not influence the construction time. Further, it is beneficial that this measure can be combined with other noise mitigation technologies in order to provide additional noise mitigation.

Possible Constraints in the Development of Innovative Foundations

After onshore- and nearshore tests, an offshore test under realistic conditions and with accompanying research is always needed in order to demonstrate the suitability of a new foundation type. The construction and installation of a suitable prototype is very costly for developers due to the lack of serial production. For economic reasons it often cannot be carried out. According to providers of innovative technologies, a possible solution, integrating single test plants into existing wind farm plans is problematic because wind farm operators naturally want to protect themselves against all

possible risks, e.g. fluctuations in yield or risk of failure. Single connections to the grid, however, are so expensive that they can rarely be realized. For this reason, predictable and easy-to-handle solutions, especially for liability regulations must be found. Furthermore, incentives for wind farm operators and investors must be given in order to enhance the attractiveness of the integration of single test plants into larger commercial wind farm projects. Another alternative would be the provision of another test field similar to *alpha ventus* in the German Bight.

Moreover, development prospects for companies should be created in order to justify large investments into innovative foundation concepts. The general reference to the 'transformation of the energy system' (known in German as the '*Energiewende*') is not sufficient. If noise limits are mandatory and have to be met permanently and reliably, low-noise foundations can establish themselves on the market. Last but not least under the aspect of noise mitigation a real (cost) advantage arises for the user of such technologies.

9 References

- ABDEL-RAHMAN, K., ACHMUS, M. (2005): Numerische Untersuchung zum Tragverhalten von Bucketgründungen für Offshore-Windenergie-Anlagen. Abaqus Benutzerkonferenz, Nürnberg
- AHRENS, C. & WIEGAND, J. (2009): Foundation of Offshore Wind Power Plants - an introduction of the Vertical Shaft Machine as an economic and ecologic alternative.
<http://search.informit.com.au/documentSummary;dn=848024769051558;res=IELENG>
(15.11.2012)
- APPLIED PHYSICAL SCIENCES (2010): Mitigation of Underwater Pile Driving Noise During Offshore Construction. Final Report. Report Nr. M09PC00019-8
http://www.boem.gov/uploadedFiles/BSEE/Research_and_Training/Technology_Assessment_and_Research/M09PC00019-8PileDrivingFinalRpt%281%29.pdf (15.11.2012)
- BALLAST NEDAM (2012): www.ballast-nedam-offshore.com/page_10352.asp (15.11.2012)
- BELLMANN, M. (2012): Die technische Entwicklung von Schallminderungstechnologien: Stand der Forschung (?). Presentation „Minimierung von Unterwasserschall bei der Gründung von Offshore-Windenergieanlagen: Anforderungen und Möglichkeiten“, IHK Rostock, 28 March 2012.
http://www.offshore-stiftung.com/60005/Uploaded/Offshore_Stiftung|2012_03_28_HRO_SOW_Schallschutz_2_Bellmann.pdf (15.11.2012)
- BETKE, K. (2008): Minderung von Unterwassergeräuschen beim Bau von Offshore WEA - Schallschutzhüllen und andere Verfahren. Presentation Workshop „Forschungsergebnisse der Begleitforschung zur Rammungsschallemission bei der Installation der Forschungsplattform FINO3“ FOWEUM, BSH Hamburg 8. Oktober 2008. http://www.offshore-wind.de/page/fileadmin/offshore/documents/FOWEUM_Workshops/Workshop_Fino3/Betke-Fino3_08.10.08.pdf (15.11.2012)
- BETKE, K. & MATUSCHEK, R. (2009): Unterwassergeräusche beim Bau und beim Betrieb des Offshore-Windparks "alpha ventus" - Untersuchungen gemäß StUk3 - Presentation.
http://www.bsh.de/de/Meeresnutzung/Wirtschaft/Windparks/StUkplus/Vortraege_Workshop/Vortrag_Bethke_Matuschek.pdf (15.11.2012)
- BETKE, K. & MATUSCHEK, R. (2010): Messungen von Unterwasserschall beim Bau der Windenergieanlagen im Offshore-Testfeld „alpha ventus“. Abschlussbericht des ITAP zum Monitoring nach StUk 3 in der Bauphase an die Stiftung Offshore-Windenergie, Varel.
http://www.bsh.de/de/Meeresnutzung/Wirtschaft/Windparks/StUk3/Fachgutachten_Bauphase_av/Schallbericht_Bauphase_2009.pdf (15.11.2012)
- BETKE, K. & MATUSCHEK, R. (2012): Hydroschallimmissionen einer Vibrationsramme. In: RUSTEMEIER et al., Abschlussbericht zum Forschungsvorhaben „Konzeption, Erprobung, Realisierung und Überprüfung von lärmarmen Bauverfahren und Lärminderungsmaßnahmen bei der Gründung von Offshore-WEA („Schall3“)", p. 101-104.
- BIOCONSULT-SH, ITAP & HYDROTECHNIK LÜBECK (2012): Projekt: HYDROSCALL OFF BW II. Entwicklung und Erprobung des „Großen Blasenschleiers“ zur Minderung der Hydroschallemissionen bei Offshore-Rammarbeiten. Förderkennzeichen 0325309A/B/C. Akustische Messungen bei den Rammungen in Forschungsphase 1 im Offshore-Windpark Borkum West II. 23. April 2012.
<http://www.hydroschall.de/wp-content/uploads/2012/05/Kurzbericht-Schallminderung20120425.pdf> (15.11.2012)
- BORA (2012): <http://www.bora.mub.tu-harburg.de/>
- BRUNS, B., KUHN, C., GATTERMANN, J., ELMER, K.-H. & IMHORST, F. (2012): Underwater noise reduction from measurements and offshore tests using systems of Hydro Sound Dampers (HSD). DE-WEK Conference, 7.-8. Nov. Bremen.

- BSH - BUNDESAMT FÜR SEESCHIFFFAHRT UND HYDROGRAPHIE (2010): Leitsätze für die Anwendung der Eingriffsregelung innerhalb der ausschließlichen Wirtschaftszone und auf dem Festlandssockel im Rahmen von § 58 Abs. 1 Satz 2 BNatSchG. online:
http://www.bsh.de/de/Meeresnutzung/Wirtschaft/Windparks/Grundlagen/Leitsaetze_Eingriffsregelung.pdf (15.11.2012)
- BSH - BUNDESAMT FÜR SEESCHIFFFAHRT UND HYDROGRAPHIE (2012): Änderungs- und Ergänzungsbescheid zu der Genehmigung „Albatros“ (Az. 511/Albatros/M5382).
http://www.bsh.de/de/Meeresnutzung/Wirtschaft/Windparks/Genehmigungsbescheide/Nordsee/Albatros/Aenderungungs- und Ergaenzungsbescheid_29022012.pdf (15.11.2012)
- CALTRANS - CALIFORNIA DEPARTMENT OF TRANSPORTATION (2001): Noise and Vibration Measurements Associated with the Pile Installation Demonstration Project for the San Francisco-Oakland Bay Bridge East Span. Final Data Report, Appendix D-8901.
- CALTRANS - CALIFORNIA DEPARTMENT OF TRANSPORTATION (2003): Underwater sound pressures associated with the restrrike of the pile installation demonstration project piles. Report prepared by Illingworth & Rodkin, Inc. for State of California, Department of Transportation.
http://biomitigation.org/reports/files/Hydroacoustic_Report_for_PIDP_Restrike_0_1263.pdf
- CALSTRANS - CALIFORNIA DEPARTMENT OF TRANSPORTATION (2007): Compendium of Pile Driving Sound Data. Prepared by Illingworth & Rodkin, Inc. for The California Department of Transportation. 129 pp. http://www.dot.ca.gov/hq/env/bio/files/pile_driving_snd_comp9_27_07.pdf (15.11.2012)
- CALSTRANS - CALIFORNIA DEPARTMENT OF TRANSPORTATION (2009): Technical Guidance for Assessment and Mitigation of the Hydroacoustic Effects of Pile Driving on Fish (Final). Prepared by ICF Jones & Stokes and Illingworth & Rodkin, Inc.
http://www.dot.ca.gov/hq/env/bio/files/Guidance_Manual_2_09.pdf (15.11.2012)
- DAZEY, E., MCINTOSH, B., BROWN, S. & DUDZINSKI, K. M. (2012): Assessment of underwater anthropogenic noise associated with construction activities in Bechers Bay, Santa Rosa Island, California. J. Env. Prot. 3: 1286-1294.
- DCNS-GROUP - DIRECTION DES CONSTRUCTIONS NAVALES, SYSTEMES ET SERVICES (2012):
<http://en.dcnsgroup.com/energy/marine-renewable-energy/winflo/> (15.11.2012)
- ELMER, K.-H., BETKE, K. & NEUMANN, T. (2007a): Standardverfahren zur Ermittlung und Bewertung der Belastung der Meeresumwelt durch die Schallimmission von Offshore-Windenergieanlagen: SCHALL2. - Project 0329947 final report. The German Federal Environment Ministry.
- ELMER, K.-H., BETKE, K. & NEUMANN, T. (2007b): Standardverfahren zur Ermittlung und Bewertung der Belastung der Meeresumwelt durch die Schallimmission von Offshore-Windenergieanlagen: Untersuchung von Schallminderungsmaßnahmen an FINO 2. - Project 0329947 A final report. The German Federal Environment Ministry.
- ELMER, K.H. (2010): Pile Driving Noise Using New Hydro Sound Dampers. ECS 2010 Workshop: Pile driving in offshore windfarms Effects on harbour porpoises, mitigation measures and standards, 21 March 2010, Stralsund.
- ELMER, K.-H., GATTERMANN, J., FISCHER, J., BRUNS, B., KUHN, B. & STRAHLMANN, J. (2011): Hydroschalldämpfer zur Reduktion von Unterwasserschall bei Offshore-Gründungen. Pfahlsymposium 2011, 17.-18.02.2011 in Braunschweig, Mitteilungen des Instituts für Grundbau und Bodenmechanik, Technische Universität Braunschweig, Heft 94, 19 pp.
- ELMER, K.H., GATTERMANN, J., KUHN, C., BRUNS, B. (2012): Hydroschalldämpfer (HSD) zur Schallminderung bei Offshore Rammarbeiten, Presentation DUH Conference „Herausforderung Schallschutz beim Bau von Offshore Windparks“, 25./26 September 2012, Berlin.
- FHWG - Fisheries Hydroacoustic Working Group (2008): Agreement in Principal for Interim Criteria for Injury to Fish from Pile Driving Activities. Memorandum of 12 June 2008.
http://www.dot.ca.gov/hq/env/bio/files/fhwgcriteria_agree.pdf (15.11.012)
- FREISEN, M. (2010): Schwerlastfundamente für den Offshore Windpark Lillgrund. Presentation at “Husum Wind” 2010.

- FRÜHLING, I., NEUBER, M., OVERDICK, E., ROLFS, M. SCHMUGLER, J., SCHÖNHERR, J. & TSAKONAKIS, A. (2011): Abschlussbericht zum Forschungsvorhaben "Konzeptstudie zur Entwicklung einer neuartigen Gründungstechnologie unter Einbeziehung von Errichtungslogistik (Teilprojekt 1) und Schallschutz (Teilprojekt2)". FKZ 0325142. 71 pp.
- GERKE, P. & BELLMANN, M. (2012): Offshore Windpark „Riffgat“. Messung der Bauschallimmissionen. Itap Projekt Nr.: 1924-12-e-pg, 40 S, commissioned by Offshore-Windpark Riffgat GmbH & Co KG
- GIPPERICH, C. (2012). Offshore Foundation Drilling, Presentation DUH Conference „Herausforderung Schallschutz beim Bau von Offshore Windparks“, 25./26 September 2012, Berlin.
- GRANDJEAN, H., JACQUES, N., ARRIGONI, M. & ZALESKI, S. (2011): Damping of Underwater Pressure Wave by Bubble Curtain. Bubble curtain workshop, Safer Seas Conference - Brest/France - 12 May 2011.
- GRAVITAS (2012): Press Release. DECC / Demonstrator. August 2012.
<http://www.gravitasoffshore.com/press/Gravitas%20Press%20Release%20-%2008.12.pdf>
(15.11.2012)
- GRIEBMANN, T. (2009): Forschungsplattform FINO 3 - Einsatz des großen Blasenschleiers. Presentation at BSH "Meeresumweltsymposium" 2009.
http://www.bsh.de/de/Das_BSH/Veranstaltungen/MUS/2009/Dokumente/Griessmann_P.pdf
- GRIEBMANN, T., RUSTEMEIER, J., BETKE, K., GABRIEL, J., NEUMANN, T., NEHLS, G., BRANDT, M., DIEDERICH, A. & BACHMANN, J. (2009): Erforschung und Anwendung von Schallminimierungsmaßnahmen beim Rammen des FINO3 - Monopiles. FKZ 0325077-A, 0325077-B, 1-130. 2009. Berlin, Bundesministerium für Umwelt, Naturschutz und Reaktorsicherheit. Final Report of BMU funded project „Schall bei FINO3“.
- GRIEBMANN, T. RUSTEMEIER, J. & ROLFES, R. (2010): Research on mitigation measures at alpha ventus. 24. Conference of the European Cetacean Society. Pile driving in offshore windfarms. Stralsund, 21 March 2010.
http://www.bsh.de/de/Das_BSH/Veranstaltungen/Cetacean_Society/Griessmann.pdf
(15.11.2012)
- HASTINGS, M. C. & POPPER, A. N. (2005): Effects of sound on fish. California Department of Transportation Contract 43A0139 Task Order, 1.
http://www.dot.ca.gov/hq/env/bio/files/Effects_of_Sound_on_Fish23Aug05.pdf
(15.11.2012)
- HEPPER, J. (2012): Ist der Große Blasenschleier nun Stand der Technik? Presentation DUH-Conference "Herausforderung Schallschutz beim Bau von Offshore-Windparks", 25.-26 September 2012, Berlin.
- HERRENKNECHT AG (2009): Machbarkeitsstudie zum Einsatz der Vertical Shaft Sinking Machine (VSM) im Bereich der Errichtung von Offshore-WEA. FKZ 0325064. Finale Report according to 8.2 NKBF 98. 20 pp.
- HERRENKNECHT AG (2010): Machbarkeitsstudie zum Einsatz der Vertical Shaft Machine (VSM) im Bereich der Errichtung von Offshore-WEA. Finale Report according to 8.2. NKBF 98 (FKZ 0325064). 20 pp.
- IBSEN, L.B.; LIINGAARD, S. & NIELSEN, S.A. (2005): Bucket Foundation, a status. Proceedings of the Copenhagen Offshore Wind 2005.
http://wind.nrel.gov/public/SeaCon/Proceedings/Copenhagen.Offshore.Wind.2005/documents/papers/Future_innovative_solutions/L.B.Ibsen_Bucket_Foundation_a_status.pdf
(15.11.2012)
- IBSEN, L.B. & NIELSEN, S.B. (2007): Case Study: Implementation of the Bucket Foundation Concept.
http://vbn.aau.dk/files/13793610/Case_Study (15.11.2012)

- KUMBARTZKY, G. (2012): The BARD Group. Small Bubble Curtain / OFT 1 and 2. Conference "Minimierung von Unterwasserschall bei der Gründung von Offshore - Windenergieanlagen. March 2012". [http://www.offshore-stiftung.com/60005/Uploaded/Offshore Stiftung|2012_03_28_HRO_SOW_Schallschutz_41_Kumbartzky.pdf](http://www.offshore-stiftung.com/60005/Uploaded/Offshore_Stiftung|2012_03_28_HRO_SOW_Schallschutz_41_Kumbartzky.pdf) (15.11.2012)
- LAUGHLIN, J. (2006): Underwater sound levels associated with pile driving at the Cape Disappointment boat launch facility, wave barrier project, Washington State Department of Transportation, Seattle, USA. 42 pp.
- LEBLANC, C. (2009): The Monopod Bucket Foundation: Recent Experience and Challenges Ahead. Presentation Hamburg Offshore Wind, 12. May 2009. http://www.gl-group.com/pdf/No12_Bakmar.pdf (15.11.2012)
- LEBLANC, C., AHLE, K., NIELSEN, S.A. & IBSEN, L.B. (2009): The Monopod Bucket Foundation - Recent experiences and challenges ahead. Poster session presented at The European Offshore Wind Conference & Exhibition, Stockholm, Sweden. http://vbn.aau.dk/files/19025671/The_Monopod_Bucket_Foundation.ppt (15.11.2012)
- LEE, K.M., HINOJOSA, K.T., WOCHNER, M.S., ARGO IV, T.F., WILSON, P.S. & MERCIER, R.S. (2010): Attenuation of low-frequency underwater sound using bubble resonance phenomena and acoustic impedance mismatching. Proceedings of Meetings on Acoustics, Volume 11, 1-17. <http://acousticalsociety.org/>
- LEE, K.M., HINOJOSA, K.T., WOCHNER, M.S., ARGO IV, T.F., WILSON, P.S. & MERCIER, R.S. (2011): Sound propagation in water containing large tethered spherical encapsulated gas bubbles with resonance frequencies in the 50 Hz to 100 Hz range. J. Acoust. Soc. Am. 130 (5), 3325-3332.
- LEE, K., WOCHNER, M.S. & WILSON, P.S. (2012): Mitigation of low-frequency underwater anthropogenic noise using stationary encapsulated gas bubbles. Proceedings of the 11th European Conference on Underwater Acoustics, 8 pp.
- LESSNER, A. (2010): Wie ein Korken im Wasser. erneuerbare energien 2/2010: 18-21
- MENTRUP, K. (2012): Schallschutz Trianel Windkraftwerk Borkum. Conference "Minimierung von Unterwasserschall bei der Gründung von Offshore-Windenergieanlagen: Anforderungen und Möglichkeiten" IHK Rostock, 28 March 2012. [http://www.offshore-stiftung.com/60005/Uploaded/Offshore Stiftung|2012_03_28_HRO_SOW_Schallschutz_42_Mentrup.pdf](http://www.offshore-stiftung.com/60005/Uploaded/Offshore_Stiftung|2012_03_28_HRO_SOW_Schallschutz_42_Mentrup.pdf) (15.11.2012)
- MERCK, T. (2012): Schallschutz in der Praxis -Welche naturschutzfachlichen Anforderungen sind erfüllt, was bleibt zu tun? Presentation Conference der Deutschen Umwelthilfe e. V. "Herausforderung Schallschutz beim Bau von Offshore-Windparks", 25.-26 September 2012, Berlin.
- NEDWELL, J. & HOWELL, D. (2004): A review of offshore windfarm related underwater noise sources. - Cowrie Report No. 544 R 0308.
- NEHLS, G., BETKE, K., ECKELMANN, S. & ROS, M. (2007): Assessment and costs of potential engineering solutions for the mitigation of the impacts of underwater noise arising from the construction of offshore windfarms. - BioConsult SH report, Husum, Germany. On behalf of COWRIE Ltd.
- NEUBER, M. & UHL, A. (2012): Optimierung der Rammparameter bei der Schlagramme. In: RUSTEMEIER et al., Abschlussbericht zum Forschungsvorhaben „Konzeption, Erprobung, Realisierung und Überprüfung von lärmarmen Bauverfahren und Lärminderungsmaßnahmen bei der Gründung von Offshore-WEA („Schall3“)", p. 46-110.
- NMFS (2007): Rationale for use of 187 dB sound exposure level for pile driving impact threshold.
- OVERDICK (2012a): <http://www.overdick.com/projects/offshore-oil-and-gas> (15.11.2012)
- OVERDICK (2012b): <http://www.overdick.com/projects/offshore-wind/#moab-dc-substation-north-sea-a> (15.11.2012)

- PEHLKE, H., NEHLS, G., BELLMANN, M., GERKE, P. & GRUNAU, C. (2012): Project: HYDROSCHALL OFF BW II. Entwicklung und Erprobung des „Großen Blasenschleiers“ zur Minderung der Hydroschallemissionen bei Offshore-Rammarbeiten. Förderkennzeichen 0325309A/B/C. Akustische Messungen bei den Rammungen in Forschungsphase 1 im Offshore-Windpark Borkum West II. 23. April 2012. <http://www.hydroschall.de/wp-content/uploads/2012/05/Kurzbericht-Schallminderung20120425.pdf> (15.11.2012)
- PETRIE, F.S. (2005): Washington State Ferries' Experience with Bubble Curtains: Purpose, Hardware, and Use. 2005 Summer Meeting/Conference of the Transportation Research Board ADC40 (A1F04) Noise & Vibration Committee.
- PRINCIPLE POWER INC. (2012): <http://principlepowerinc.com/products/windfloat.html> (15.11.2012)
- RAGHEB, M. (2010): Offshore Wind Farms Siting. <https://netfiles.uiuc.edu/mragheb/www/NPRE%20475%20Wind%20Power%20Systems/Offshore%20Wind%20Farms%20Siting.pdf> (15.11.2012)
- RICHARDSON, W. J., GREENE, C. R., MALME, C.I. & THOMSON, D.H. (1995): Marine mammals and noise. Academic Press. San Diego. 576 pp.
- ROSENBERGER, F., ZEDLER, T. & WIEGAND, J. (2011): Ein Bohrer sticht in See. Erneuerbare Energien 05/2011: 54-59
- RUSTEMEIER, J., NEUBERT, M., GRIEBMANN, T., EWALDT, A., UHL, A., SCHULTZ-VON GLAHN, M., BETKE, K., MATUSCHEK, R. & LÜBBEN, A. (2012): Konzeption, Erprobung, Realisierung und Überprüfung von lärmarmen Bauverfahren und Lärminderungsmaßnahmen bei der Gründung von Offshore-Windenergieanlagen ("Schall 3"). FKZ 0327645. Institut für Statik und Dynamik an der Gottfried Wilhelm Leibniz Universität Hannover, Hannover. 236 S.
- SALEEM, Z. (2011): Alternatives and modifications of Monopile foundation or its installation technique for noise mitigation. Report commissioned by the North Sea Foundation, 66 pp. www.vliz.be/imisdocs/publications/223688.pdf
- SCHULTZ-VON GLAHN, M., BETKE, K. & NEHLS, G. (2006): Minderung des Unterwasserschalls bei Rammarbeiten für Offshore-WEA - Praktische Erprobung verschiedener Verfahren unter Offshore-Bedingungen. UFOPLAN 205 53 113. Umweltbundesamt. Dessau. 59 pp.
- SEACORE (2012): Shah Deniz, Baku <http://www.seacore.com/projects/shah-deniz-baku> (15.11.2012)
- SCHULTZ-VON GLAHN, M. (2011): Messung der Hydroschall-Immissionen bei Probe-Rammarbeiten am Offshore-Windpark EnBW Baltic 2 sowie Messung und Beurteilung der Wirksamkeit von Schallminderungsmaßnahmen. Report, Project Nr. 1653-10-svg, 9 June 2011, 33 pp.
- SIEMENS (2009): Hywind: Siemens und StatoilHydro installieren erste schwimmende Windenergieanlage. Press Release 10 June 2009. http://www.siemens.com/press/de/pressemitteilungen/?press=/de/pressemitteilungen/2009/renewable_energy/ere200906064.htm (15.11.2012)
- SNIECKUS, D. (2011): SPT's three-legged wind turbine foundation braced for next stage. ReCharge Nov. 2011. <http://www.rechargenews.com/wind/article1294800.ece> (01.02.2013)
- SOUTHALL, B.L., BOWLES, A.E., ELLISON, W.T., FINNERAN, T.E., GENTRY, R.L., GREENE JR., C.R., KASTAK, D., KETTEN, D., MILLER, J.H., NACHTIGALL, P.E., RICHARDSON, W.J., THOMAS, J.A. & TYACK, P.L. (2007): Marine Mammal Noise Exposure Criteria: Initial Scientific Recommendations. - Aquatic Mammals 33(4): 411-521.
- STADLER, J. H. & WOODBURY, A.P. (2007): A proposed method to assess physical injury to endangered fishes and essential fish habitat from underwater sound produced by pile driving. - Poster, presented at the international conference "The effects of noise on aquatic life", Nyborg, August 2007.
- STEINHAGEN, U. (2009): Transient FE Simulation of the Hydro-Acoustics during Pile Driving, presented at the ANSYS Conference & 27th CADFEM Users Meeting, Leipzig, Germany, November 2009.
- STEINHAGEN, U. & MOOS-RAINER, M. (2011): Forecasting underwater noise: Simulation soundly predicts hydro-acoustics during offshore pile driving. ANSYS Advantage V(2): 16-17.

- STEINHAGEN, U. (2012): Kleiner Blasenschleier, Presentation Conference of „Deutschen Umwelthilfe e. V.“ “Herausforderung Schallschutz beim Bau von Offshore-Windparks”, 25.-26. September, Berlin
- STRABAG (2012): <http://www.strabag-offshore.com/projekte/schwerkraft-testfundament.html> (15.11.2012)
- SUKUMARAN, B. (ohne Jahr): Suction Caisson Anchors - A Better Option For Deep Water Applications. (<http://users.rowan.edu/~sukumaran/personal/publications/swe1.pdf>)
- SØRENSEN, H.C.; HANSEN, H.K. & LARSEN, J.H.M. (2002): Middelgrunden 40 MW Offshore Wind Farm Denmark - Lessons Learned (<http://www.oceanrenewable.com/wp-content/uploads/2007/03/middlegrundendenwindlessonsspok02.pdf>)
- THOMSEN, K.E. (2012): Cofferdam-State of the art noise mitigation, Presentation Conference of “Deutsche Umwelthilfe e. V.” “Herausforderung Schallschutz beim Bau von Offshore-Windparks”, 25.-26 September 2012, Berlin.
- THOMSEN, J.H., FORSBERG, T. & BITTNER, R. (2007): Offshore Wind Turbine Foundation - the COWI experience. Proceedings of the 26th International Conference on Offshore Mechanics and Arctic Engineering. OMAE2007. June 10-15, 2007, San Diego, California, USA. OMAE2007-29567. [http://www.bittner-shen.com/publication/Caissons/Offshore Wind Turbine Foundations The COWI Experience.pdf](http://www.bittner-shen.com/publication/Caissons/Offshore_Wind_Turbine_Foundations_The_COWI_Experience.pdf) (15.11.2012)
- TÜV SÜD (2012): <http://www.pressebox.de/pressemitteilung/tuev-sued-ag/TUeV-SUeD-zertifiziert-Offshore-Projekt-Albatros-1-von-Strabag/boxid/415884> (15.11.2012)
- UMWELTBUNDESAMT (2011): Empfehlung von Lärmschutzwerten bei der Errichtung von Offshore-Windenergieanlagen (OWEA). Umweltbundesamt Dessau, Germany, 6 pp. <http://www.umweltdaten.de/publikationen/fpdf-l/4118.pdf> (15.11.2012)
- VAGLE, S. (2003): On the Impact of Underwater Pile-Driving Noise on Marine Life. Institute of Ocean Sciences, DFO/Pacific, Ocean Science and Productivity Division.
- VAN DE BRUG, E. (2009): Drilled Concrete Monopile. [http://www.bsh.de/en/The BSH/Events/Cetacean Society/index.jsp](http://www.bsh.de/en/The_BSH/Events/Cetacean_Society/index.jsp) 15.11.2012)
- VAN DE BRUG, E. (2011): Drilled Concrete Monopile -Kriegers Flak R&D Project - Executive Summary. In: VON NORDHEIM, H., KRAUSE, J.C. & MASCHNER, K. (Eds.): Progress in Marine Conservation in Europe 2009. 2nd International Conference on Progress in Marine Conservation in Europe. BfN-Skripten 287, 151-158.
- VAN VESSEM, H. (2012): IHC Offshore Systems. Presentation, held at the “Symposium Sound Solutions”, North Sea Foundation, February 02 2012. <http://www.noordzee.nl/wp-content/uploads/2011/11/ihc-noise-mitigation-screen.pdf> (15.11.2012)
- VATTENFALL (2008): Experiences from the construction and installation of Lillgrund wind farm. [http://www.vattenfall.se/sv/file/Experiences from the construc 11336756.pdf](http://www.vattenfall.se/sv/file/Experiences_from_the_construc_11336756.pdf) (15.11.2012)
- VATTENFALL (2009): Exclusive Summary: Conceptual Foundation Study for Kriegers Flak Offshore Wind Farm, SWEDEN. September 2009. European Offshore Wind 2009. <http://www.docstoc.com/docs/50666563/Exlusive-Summary-Conceptual-Foundation-Study-for-Kriegers-Flak> (15.11.2012)
- VERFUß, T. (2012): Noise Mitigation Measures & Low-noise Foundation Concepts - State of the Art. International Symposium “Towards an Environmentally Sound Offshore Wind Energy Deployment” Stralsund, 25.01.2012. http://www.bfn.de/fileadmin/MDB/documents/themen/erneuerbareenergien/Tgng_offshore2012/6_1_verfuss.pdf (15.11.2012)
- WAHRMUND, H. (2012): Offshore Wind Schwerkraftfundamente, Presentation Conference of “Deutsche Umwelthilfe e. V.” “Herausforderung Schallschutz beim Bau von Offshore-Windparks”, 25.-26 September 2012, Berlin.

- WEINHOLD, N. (2008): Schwimmende Stromparks. *Neue energie* 1/08: 26.
- WEYRES, B. (2012): Die BEKA Schale als Schallminderung für Impulsrammung, Presentation Conference of "Deutsche Umwelthilfe e. V." "Herausforderung Schallschutz beim Bau von Offshore-Windparks", 25.-26 September 2012, Berlin.
- WILKE, F., KLOSKE, K. & BELLMANN, M. (2012): ESRA-Evaluierung von Systemen zur Rammschallminderung an einem Offshore-Testpfahl. Förderkennzeichen 0325307. Technical Report Mai 2012. http://www.offshore-stiftung.com/60005/Uploaded/Offshore_Stiftung|ESRa_TechnischerAbschlussbericht.pdf (15.11.2012)
- WINDSEA (2012): <http://windsea.com/sfiles/07/1/file/windsea.pdf> (15.11.2012)
- WÜRSIG, B., GREENE, C. R. JR. & JEFFERSON, T. A. (2000): Development of an air bubble curtain to reduce underwater noise of percussive piling. *Mar. Environ. Res.* 49: 79-93).
- ZERBST, S. & RUSTEMEIER, J. (2011): Bericht über Messungen des Hydroschalls im Rahmen der Proberammungen für den zukünftigen Offshore-Windpark Baltic II. ISD-A-04/2011, March 2011, 18 pp.