



Pacific
Northwest
NATIONAL LABORATORY

Entanglement risk of marine animals in the mooring lines of marine energy devices and oceanographic instruments

Lenaïg Hemery
Andrea Copping
Kristin Jones



PNNL is operated by Battelle for the U.S. Department of Energy

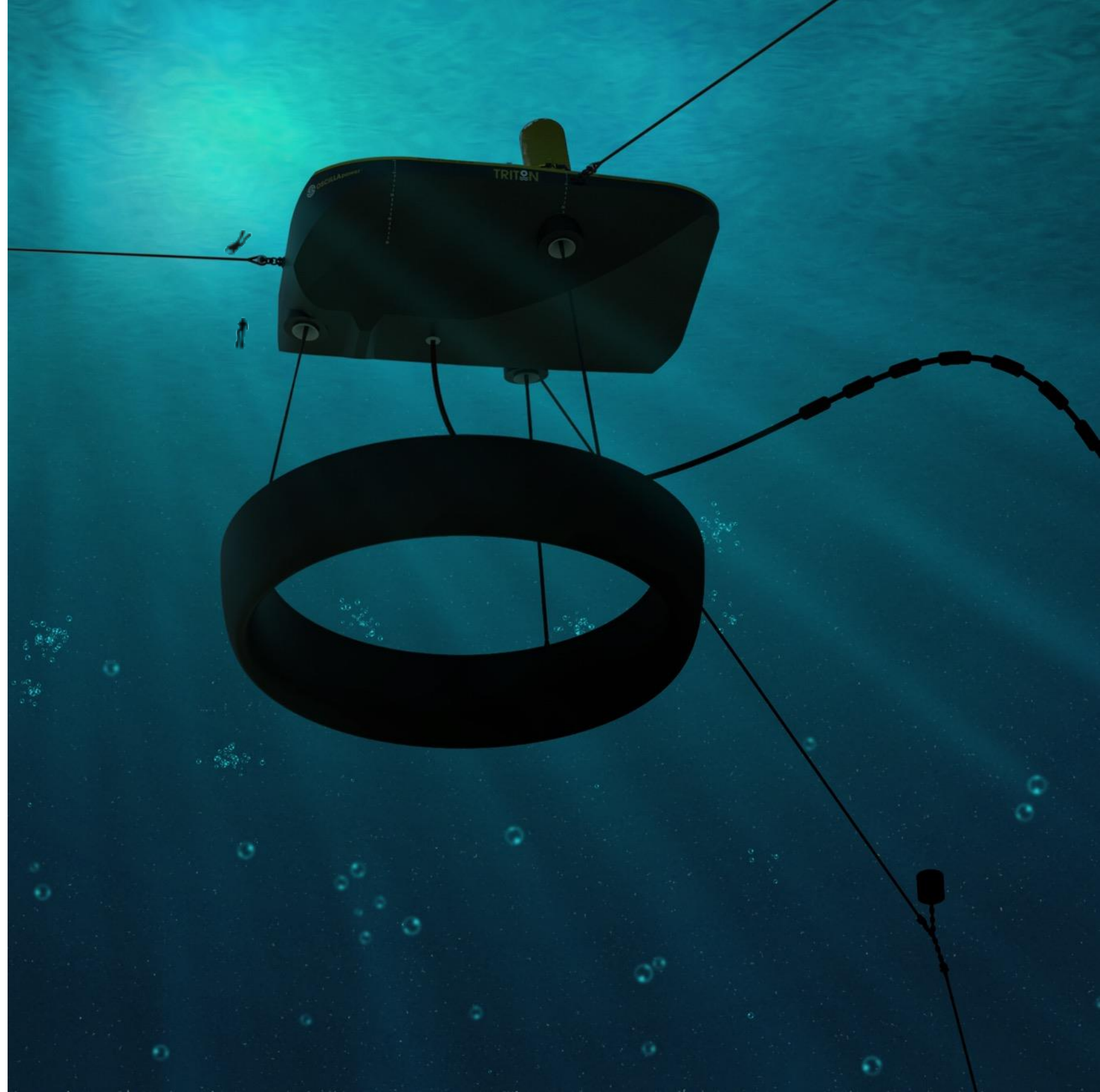
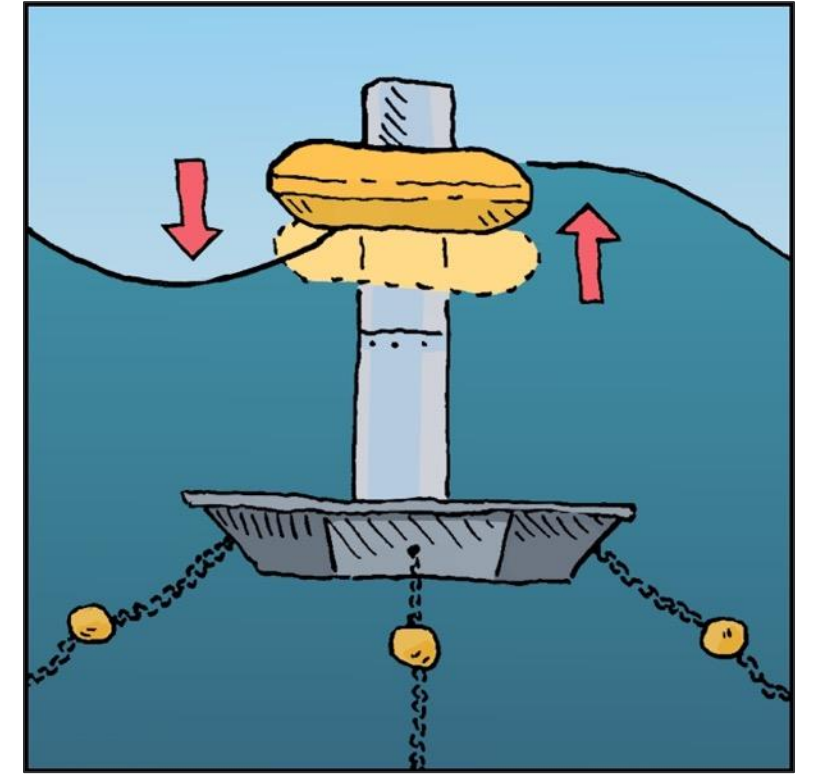
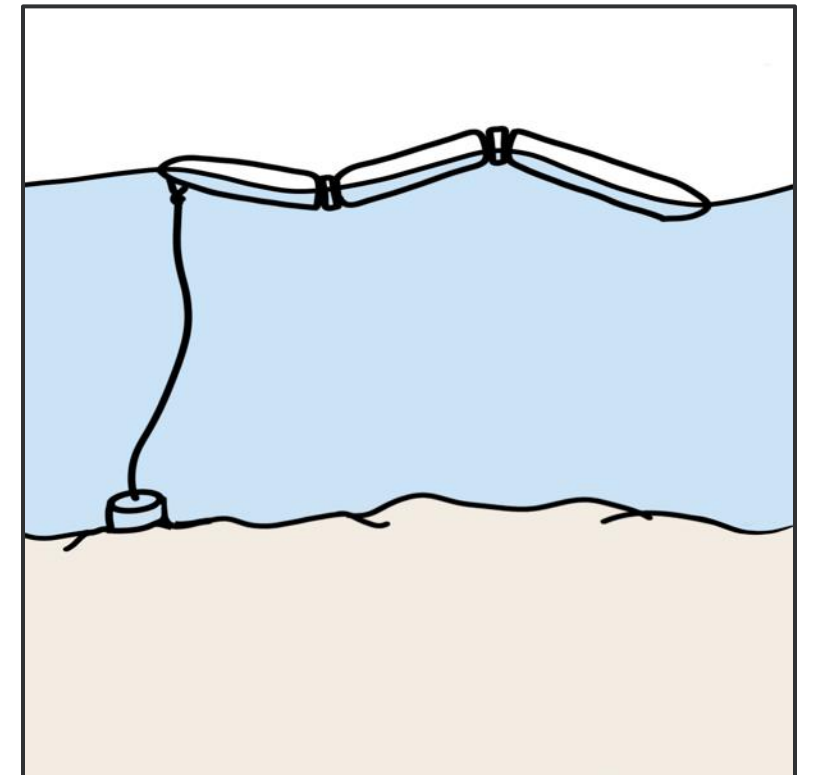

Table of Content

1. [Introduction](#)
2. [Marine energy devices with mooring lines](#)
3. [Oceanographic instruments with mooring lines](#)
4. [Mooring system material and design](#)
5. [Mooring system entanglement risk](#)
6. [Animals at risk and their specificities](#)
7. [Entanglement risk to marine megafauna](#)
8. [Entanglement mitigation strategies](#)
9. [Conclusions](#)
10. [References](#)



Ian Hermanson (PNNL)



Cailene Gunn (PNNL)

1. Introduction

- Floating and submerged structures in the ocean, such as marine energy devices and relevant oceanographic instruments, use mooring lines tethered to them and to an anchor to hold them in place on the seafloor.
- Mooring lines and mooring systems may be fabricated from a variety of materials in different configurations depending on the type of device to be tethered, the depth, and the seafloor topography of the location.
- As the marine energy industry and the need for ocean observation increase, concerns around the effects of devices, mooring systems, and moored observing equipment will need to be addressed to minimize potential risks to marine animals.
- One such concern is the potential for marine mammals, sea turtles, large fish, diving seabirds, and other marine animals to become entangled in mooring systems and lines associated with devices and buoys.
- Because of devices, instruments, and their mooring systems acting as artificial reefs and fish aggregating devices (Kramer et al., 2015), the large predatory animals may become attracted to these artificial structures (Hemery et al., 2024), increasing the risk of interacting with the mooring systems.
- Entanglement in lines or cables could cause serious harm to animals, such as tissue damage, make movement difficult for animals, and even drowning and death (Benjamins et al., 2014).



Azura Wave Energy

1. Introduction

- Since few marine energy devices have been deployed, research around entanglement risk has had to focus on data collected from surrogates such as other ocean industries, including offshore oil and gas production, fishing, etc.
- While the characteristics of mooring systems depend on the site's conditions and the structure to secure, those used for large vessels, oil platforms, floating wind turbines, and marine energy devices are very similar in configuration, material, and line diameter.
- For example, mooring systems used for floating wind turbines have a line diameter between 76 mm and 234 mm (Jiang, 2025), while those used in the oil and gas industry vary between 95 mm and 290 mm (Ahmed Ali et al., 2020), and those for marine energy devices between 130 mm and 203 mm (Lee et al., 2025).
- In contrast, mooring lines used to secure oceanographic instruments are much thinner, with a diameter between 4.8 mm and 25 mm.

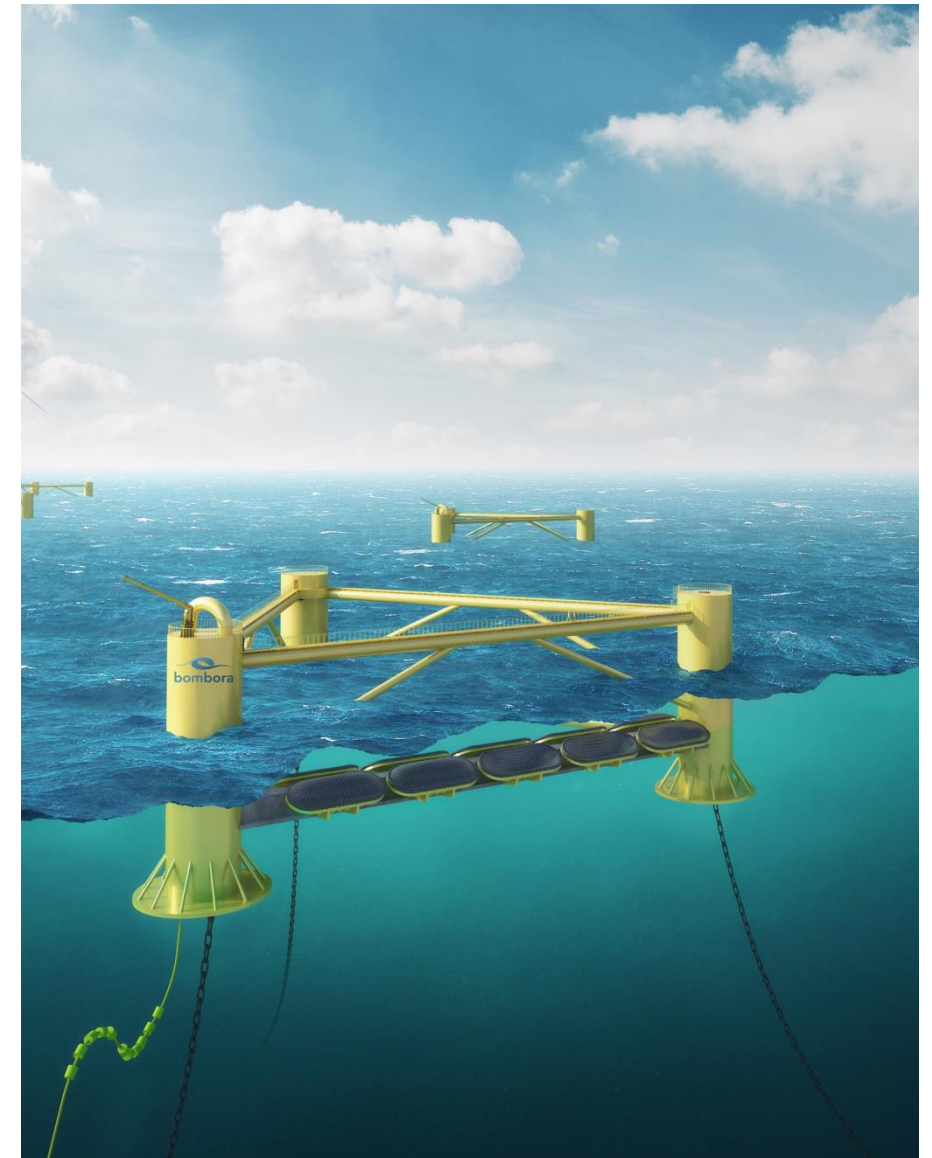

1. Introduction

- The video below offers a visualization of the scale of a humpback whale and her calf compared to the mooring lines and cables of floating offshore wind.



<https://tethys.pnnl.gov/publications/humpback-whales-floating-offshore-wind-farm-animation>

1. Introduction

- The goal of this white paper is to summarize the available information about entanglement risk for marine megafauna from the mooring systems associated with marine energy devices and oceanographic instruments.
- The literature associated with configurations and materials used for mooring systems for both technologies, as well as the factors that may increase the risk of entanglement for various marine megafauna, such as distribution, swimming behavior, and detection capabilities, are synthesized.
- Mitigation and reduction strategies for decreasing entanglement risk around moorings are discussed.

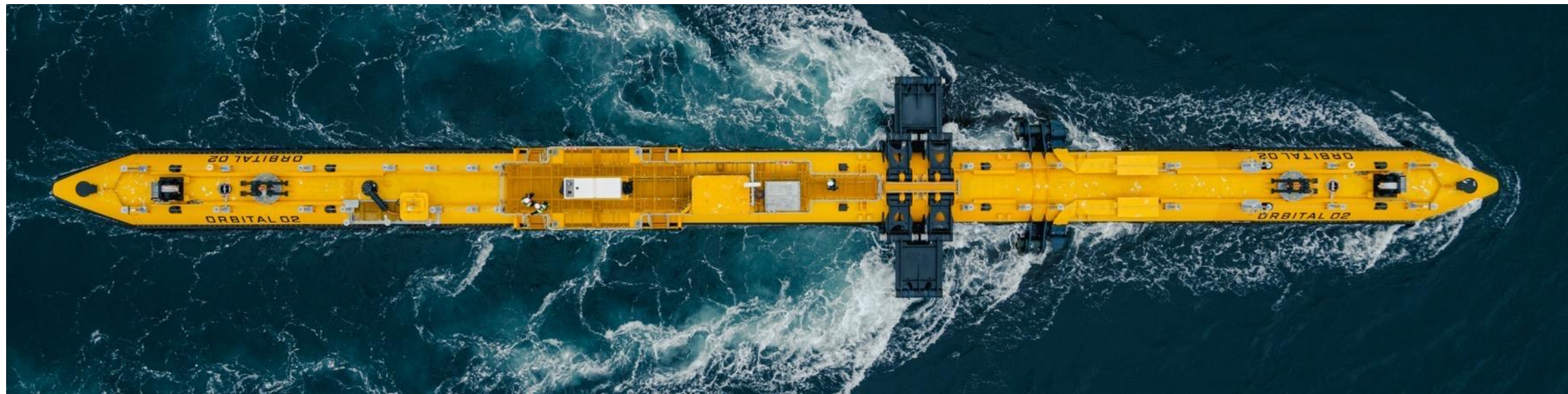

Orbital Marine Power

2. Marine energy devices with mooring lines

- Floating marine energy devices, both wave energy converters (WECs) and tidal turbines, come in multiple shapes and forms, requiring various mooring configurations.
- Depending on the device archetype, moorings can serve two purposes: station keeping and/or providing a reaction force for energy harvesting.
- The major wave and tidal energy archetypes and preferred mooring systems are outlined in the following slides.

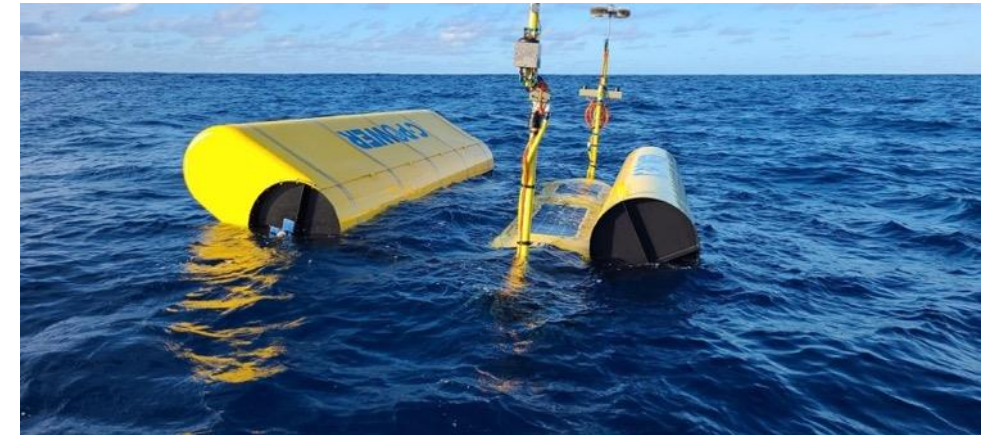

C-Power



IDOM



Sustainable Marine

2. Marine energy devices with mooring lines

a. Wave energy converters

- While some WECs are installed on the seafloor (without lines in the water column), most common designs float at the surface or subsurface and are attached to the seafloor with mooring systems.

Point absorber

- Point absorber WECs extract energy through the vertical motion of the waves.
- Point absorbers leverage the relative movement of a fixed body on the seabed, or submerged platform, and a floating body that moves vertically, providing linear motion to a power take off, generally in a rotational manner ([link](#)).
- These devices generally have a single tether attaching them to an anchor on the seafloor, which usually acts as a reaction force.

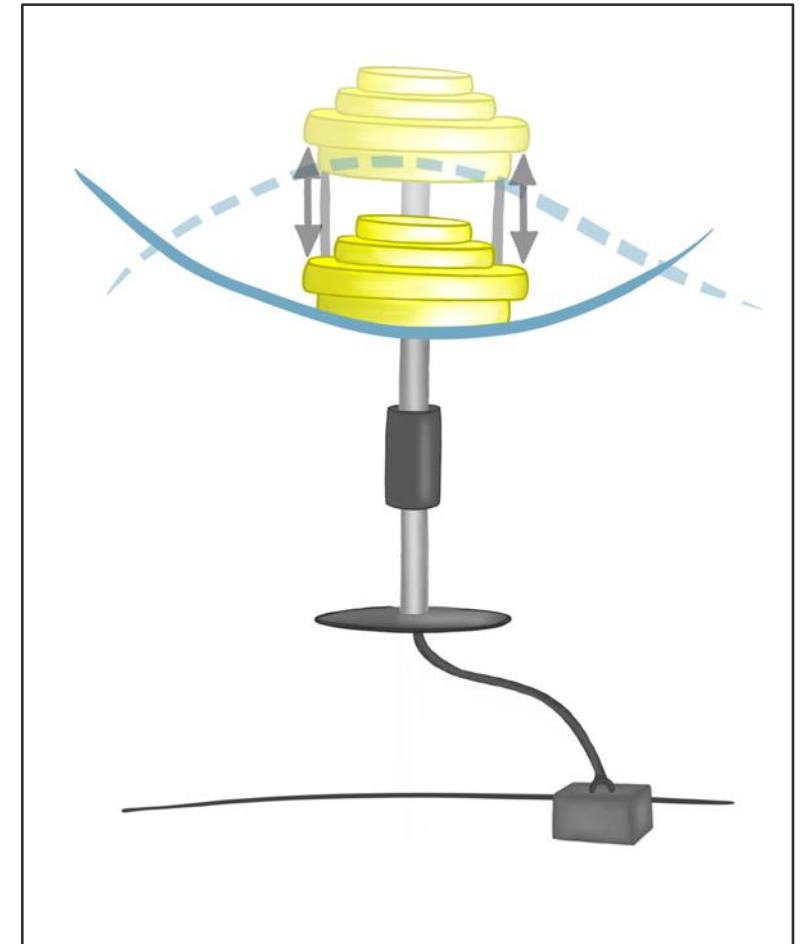

Candace Briggs (PNNL)

Illustration of a generic point absorber

2. Marine energy devices with mooring lines

a. Wave energy converters

Attenuator

- Attenuator WECs consist of surface floating bodies that operate parallel to the wave fronts.
- The segments rise and fall with the wave motion, generating hydraulic power from the flexing motion to a power take off ([link](#)).
- Depending on the length, attenuators are secured to the seafloor with one or more mooring lines.
- In this case, mooring lines are used for station keeping only.

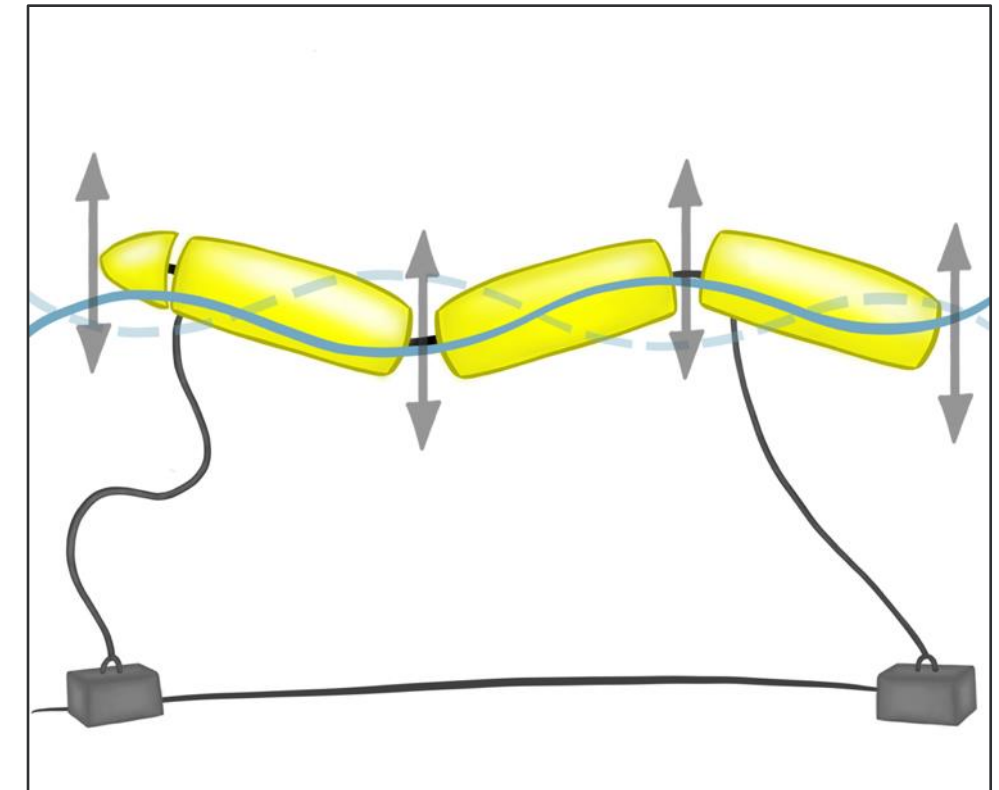

Candace Briggs (PNNL)

Illustration of a generic wave attenuator device

2. Marine energy devices with mooring lines

a. Wave energy converters

Floating overtopping

- Overtopping WECs consist of large surface structures that include a reservoir higher than the surface of the ocean.
- Waves overtop the reservoir, resulting in pressure that forces the water through a turbine to a power take off ([link](#)).
- Overtopping devices tend to be large and are usually secured to the seafloor with multiple mooring lines that prevent translation and rotation in the swell.

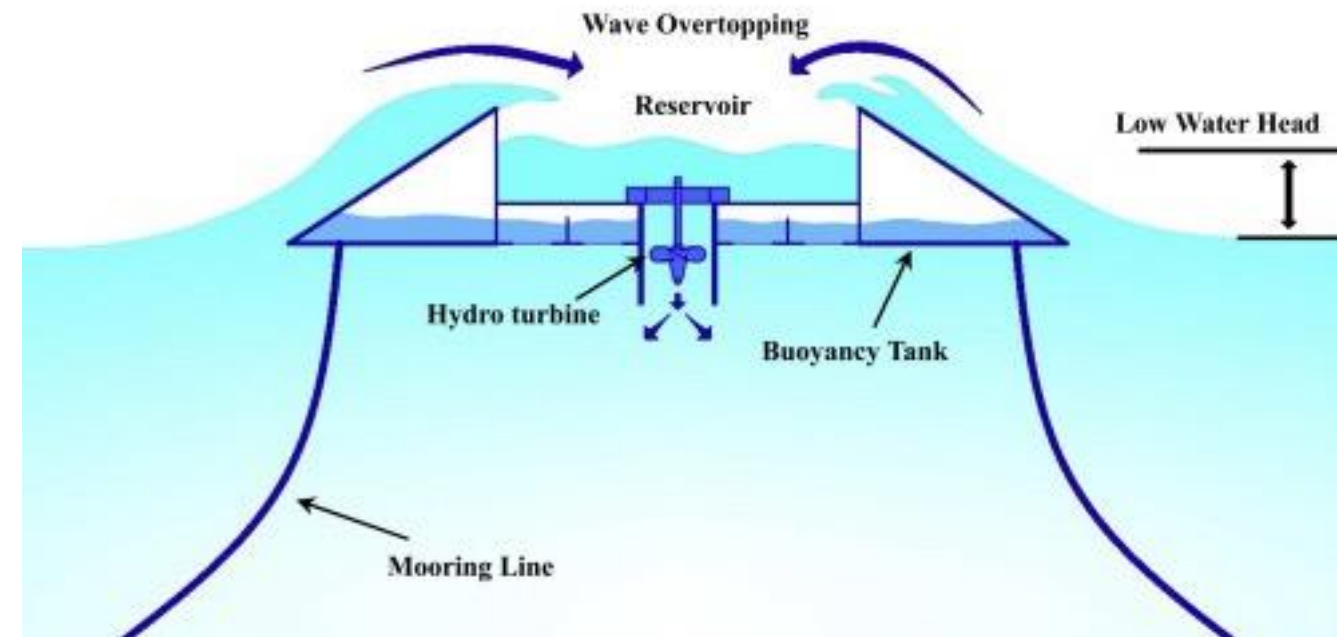

Illustration of a generic wave overtopping device

2. Marine energy devices with mooring lines

b. Tidal energy converters

- Many tidal energy converters are bottom-mounted, with a gravity or piled connection to the seafloor. These devices do not require mooring lines and are not considered to be an entanglement risk for marine animals.

Tidal kite

- A tidal kite is secured to the seabed with a single tether that allows the neutrally buoyant submerged device to “fly” through the water column.
- The kite consists of a hydrodynamic wing and turbine, and a taut tether.
- As the kite flies, the enhanced current flow generates power from a power take off ([link](#)).

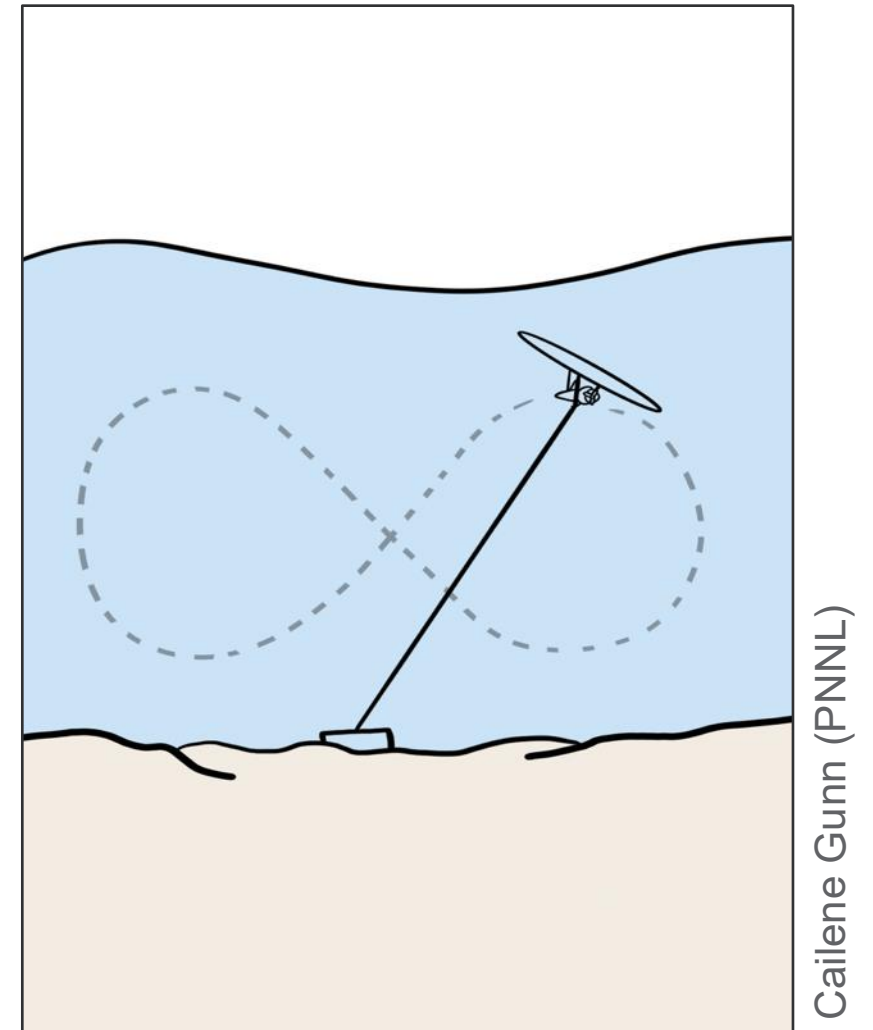

Illustration of a generic tidal kite

2. Marine energy devices with mooring lines

b. Tidal energy converters

Floating tidal platform

- Floating tidal turbines consist of a floating body with turbines mounted below the surface structure, allowing for easier access and maintenance.
- The floating body is held in position through a mooring system tethered to the seafloor.
- As many of these devices are large, they often require multiple mooring lines.
- Depending on the devices, mooring systems may need to limit translation and rotation, while others just account for tidal range.

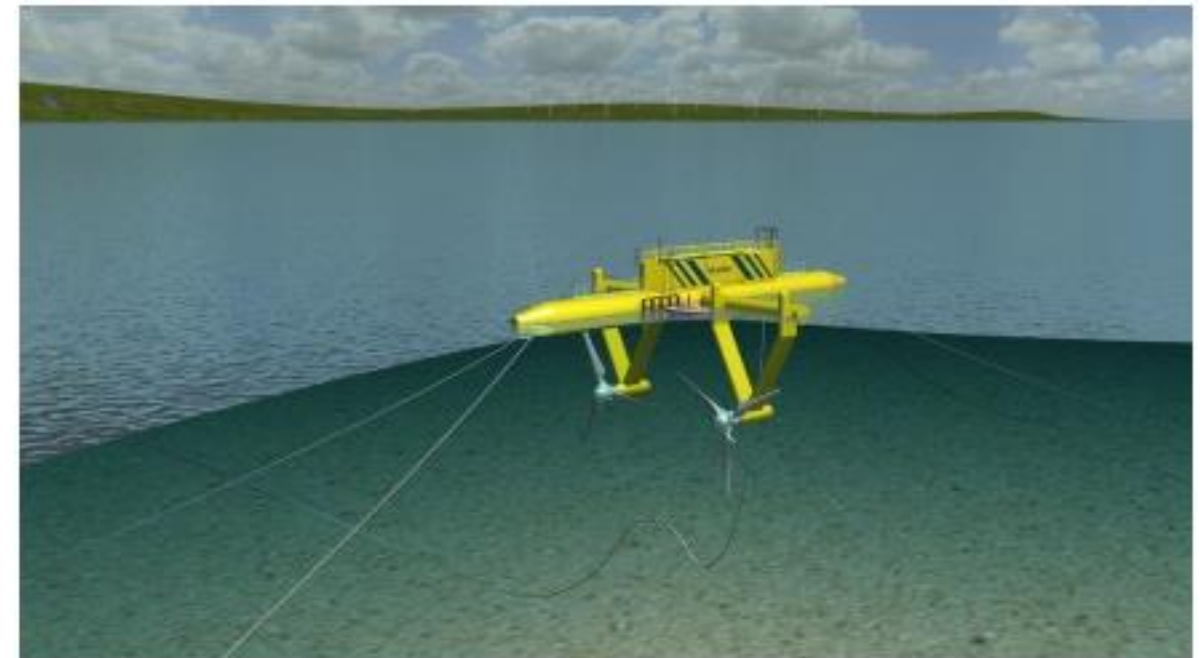

BlueTEC

Illustration of a generic floating tidal platform

2. Marine energy devices with mooring lines

c. Marine energy device arrays

- Multiple floating marine energy devices may be deployed in arrays to increase power output.
- Generally, each device will be held in place with individual mooring lines, although some sharing of lines has been suggested.
- In addition, power cables will connect individual devices in order to export power to shore through an integrated cable; these cables may be draped in the water column.

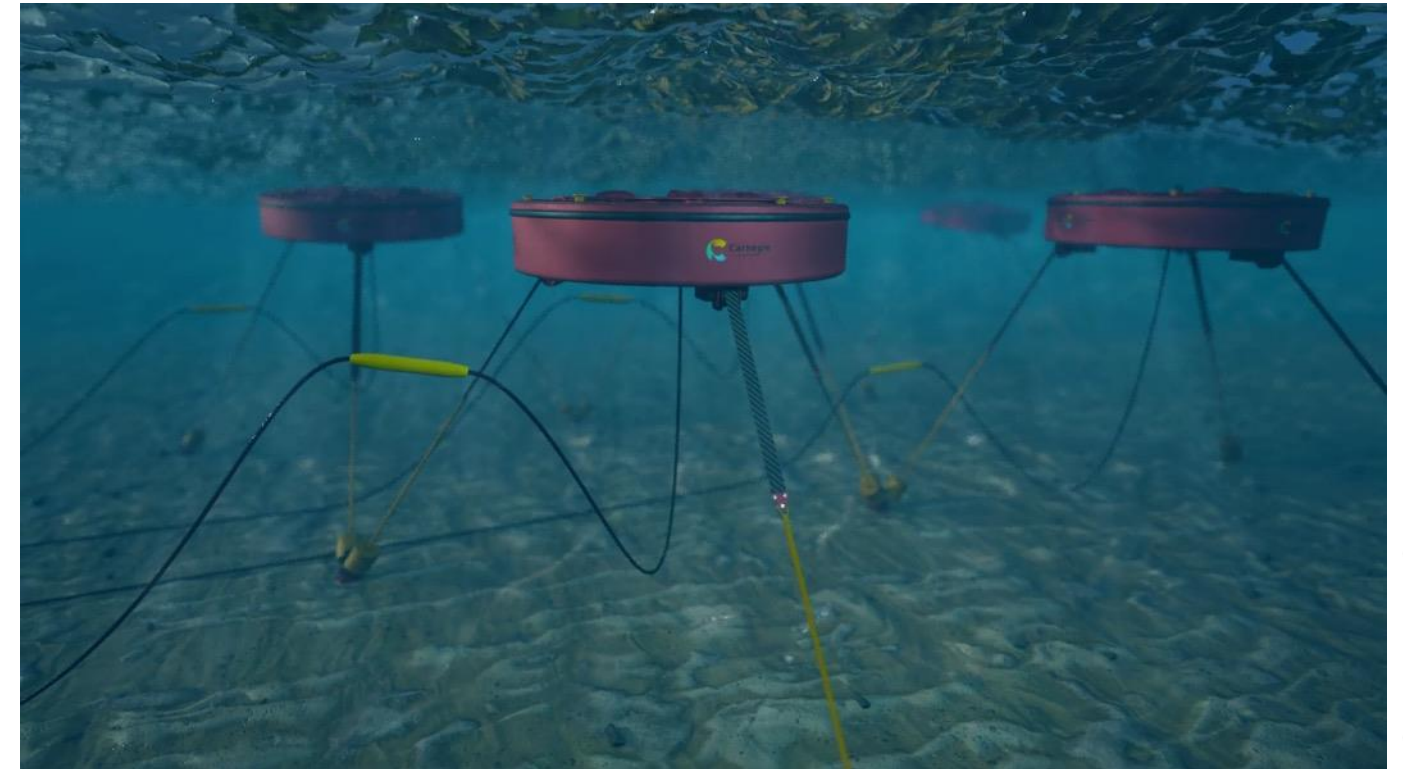

Example of a hypothetical array of subsurface wave energy devices with taut moorings and export cables

3. Oceanographic instruments with mooring lines

- Oceanographic instruments and platforms are deployed in many areas of the oceans from estuaries and shallow coastal areas to the open ocean for observations ranging from hours to years, and may be associated with marine energy deployments to measure the energy resource available and/or to monitor conditions at the site.
- These instruments collect data to explain the fundamental workings of the ocean, as well as tracking changes occurring from natural and anthropogenic forces.
- Instruments may be deployed on the seafloor, throughout the water column, and occasionally on the surface. These instruments may be free floating, but most are anchored to the seafloor in some manner, with gravity foundations for bottom mounted, and with anchors, mooring lines, and buoyancy for the water column and surface placements.

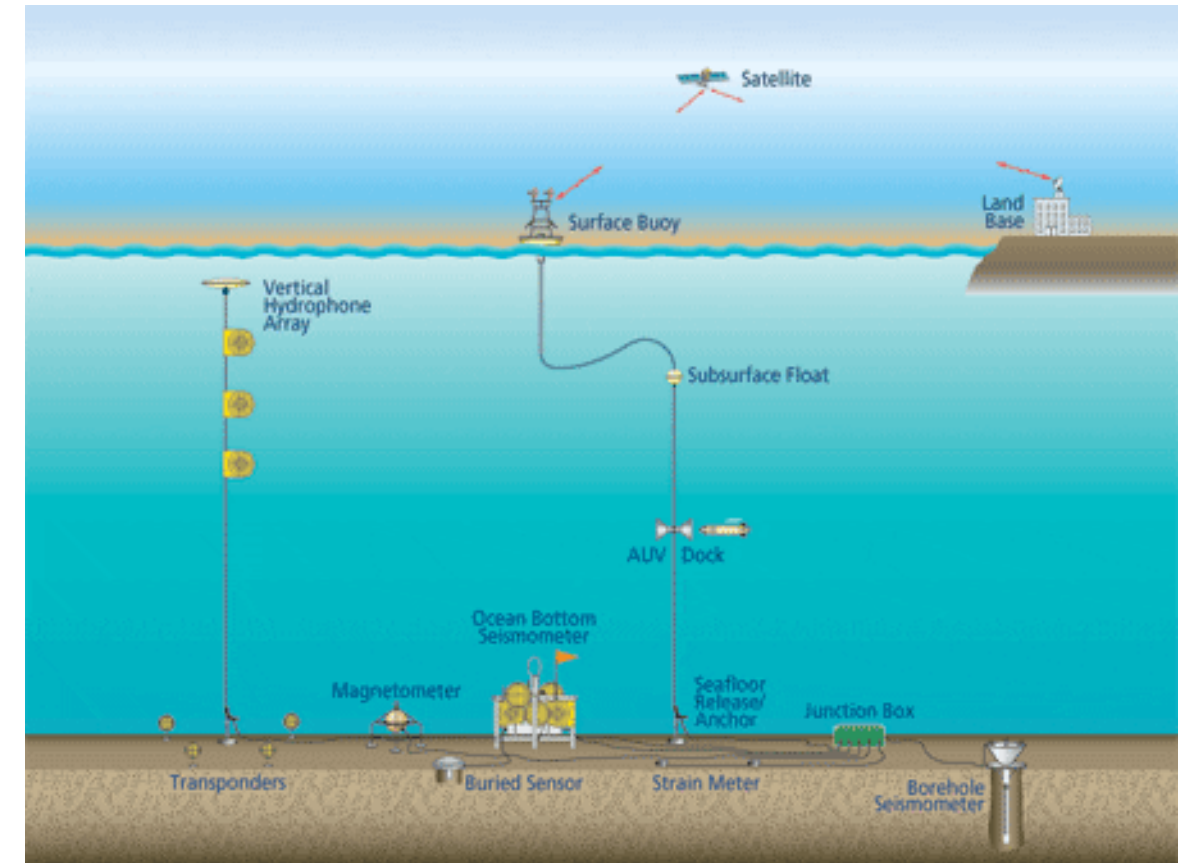

Examples of seafloor, subsurface, and surface oceanographic instruments and platforms with foundations, anchors, and mooring lines

3. Oceanographic instruments with mooring lines

- Typically, anchored oceanographic instruments that are intended to collect data over a long period of time do not include surface expressions as these present a vulnerability to adverse winds and waves, or in the case of near-coastal or navigation route deployments, interference from human activities (vessel allisions, fishing gear, vandalism, etc.).
- However, short-term deployments of instruments may include a surface float, sometimes with a navigation mast and lights; a common practice with these deployments may include a second float with a buoyant surface line to the buoy that supports the instrument mooring, for simplified retrieval.
- Subsurface instruments are typically moored to the seafloor, with flotation that keeps the instruments at the desired data collection depth under line tension; the flotation will bring the instrument line to the surface for retrieval with a release signal triggered by the investigator from the surface, most commonly an acoustic signal.



4. Mooring system material and design

- Moorings are generally designed symmetrically to keep forces on the device balanced; however, in some situations an asymmetrical mooring may be adopted when ocean or seabed conditions require.
- Materials and design considerations are important to maintain performance and reduce mooring line failure (Xu et al., 2019).
- Mooring line failure can cause injury to both humans and marine animals, harm to the marine environment, blockage of waterways, and financial and property damage (Xu et al., 2019).

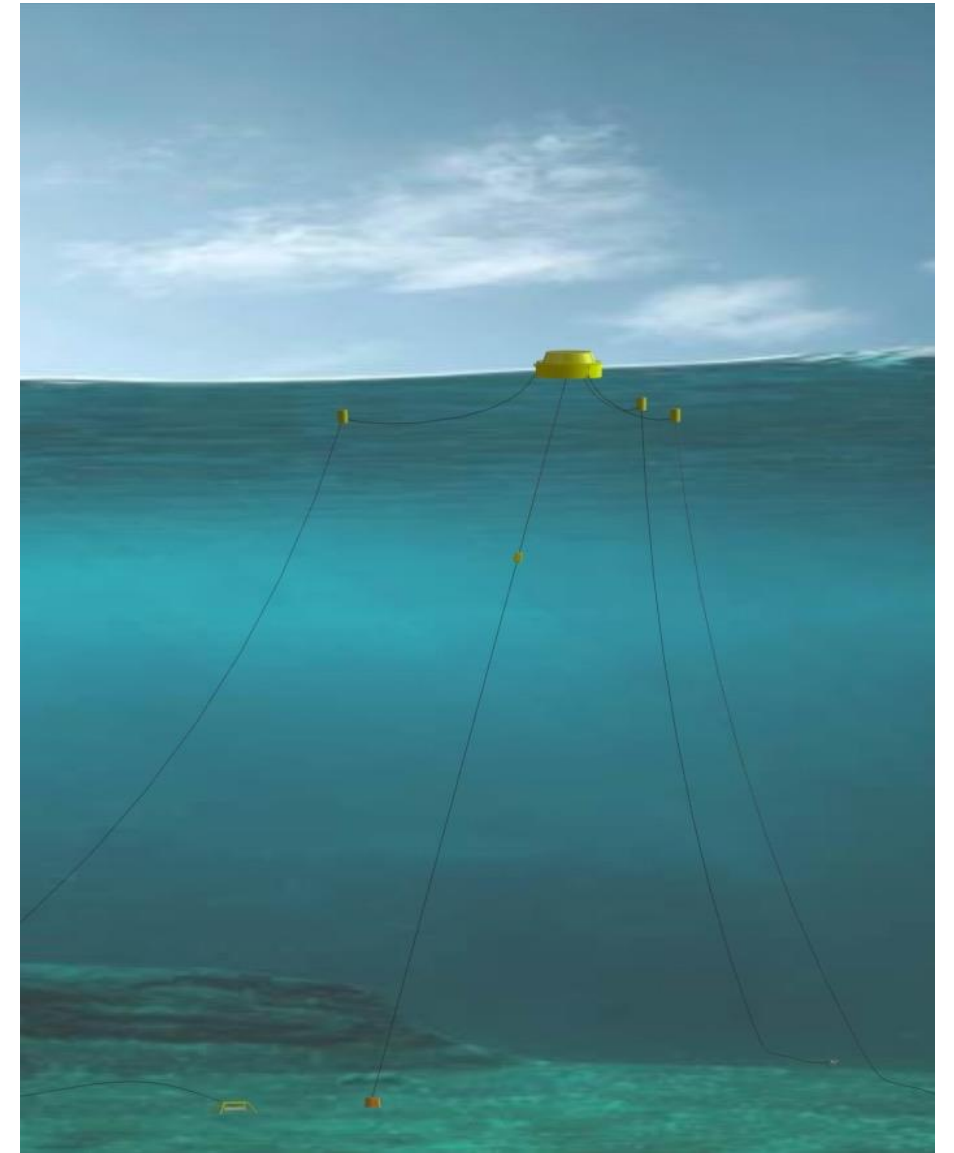

4. Mooring system material and design

a. Marine energy specificities

- Marine energy moorings generally are designed as single point moorings or spread moorings (Maheen & Yang, 2023).
- Single point moorings consist of one connecting point between the mooring system and the device.
- Single point moorings may attach mooring lines to a surface or subsurface body that will allow the device to freely rotate.
- Typical single point mooring systems can include turret mooring systems, catenary anchor leg moorings (CALM), and single anchor leg moorings (SALM) (Xu et al., 2019).

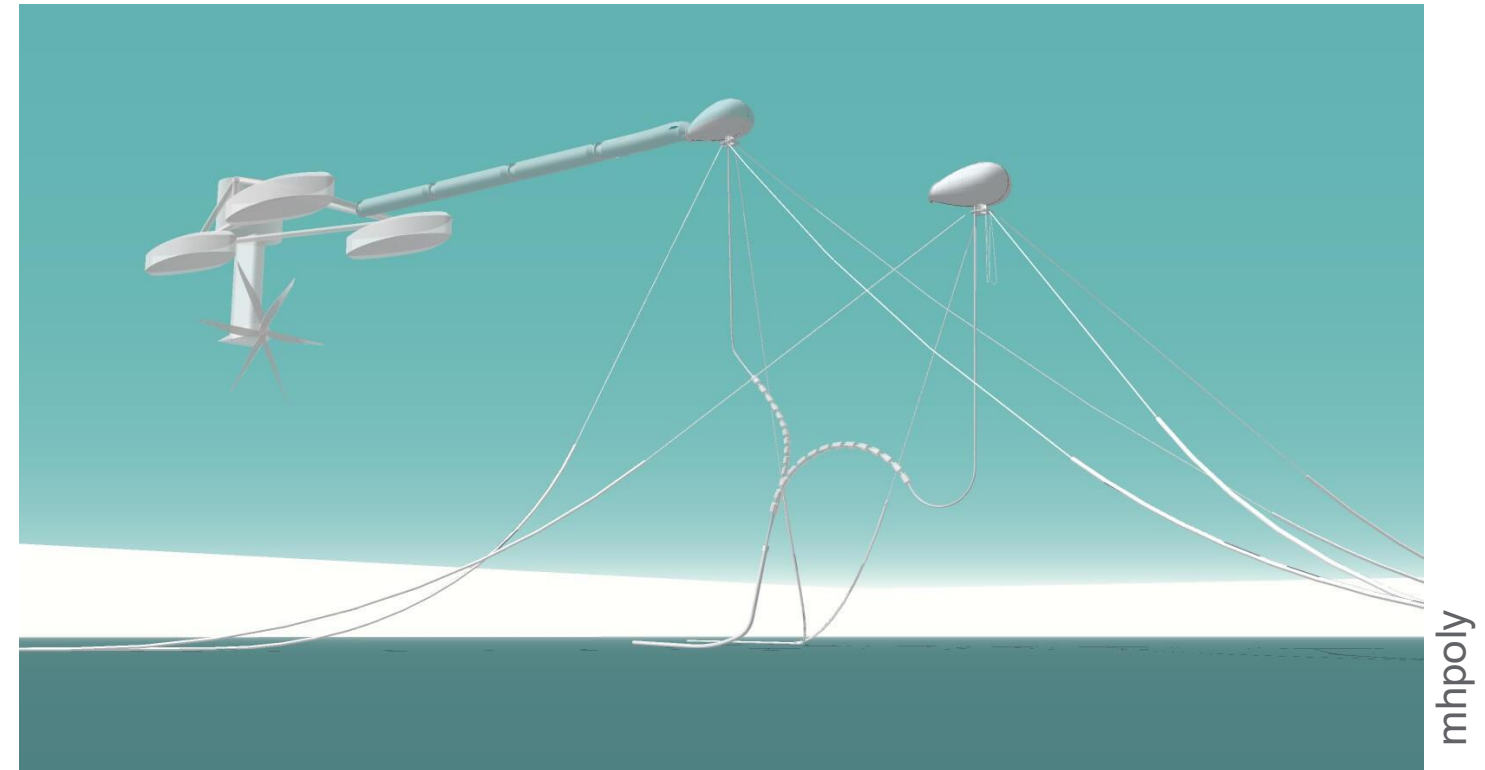

Example of turret mooring system for a couple of floating tidal turbine platforms

4. Mooring system material and design

a. Marine energy specificities

- Spread moorings consists of multiple points of connection between the mooring system and the device (Maheen & Yang, 2023).
- There are a variety of spread mooring types, commonly categorized into catenary moorings and taut moorings.
- Catenary moorings may have a section of chain lying on the seafloor between the mooring line and the anchor.
- Catenary moorings are the most commonly used for marine energy deployments (EMEC, 2016).

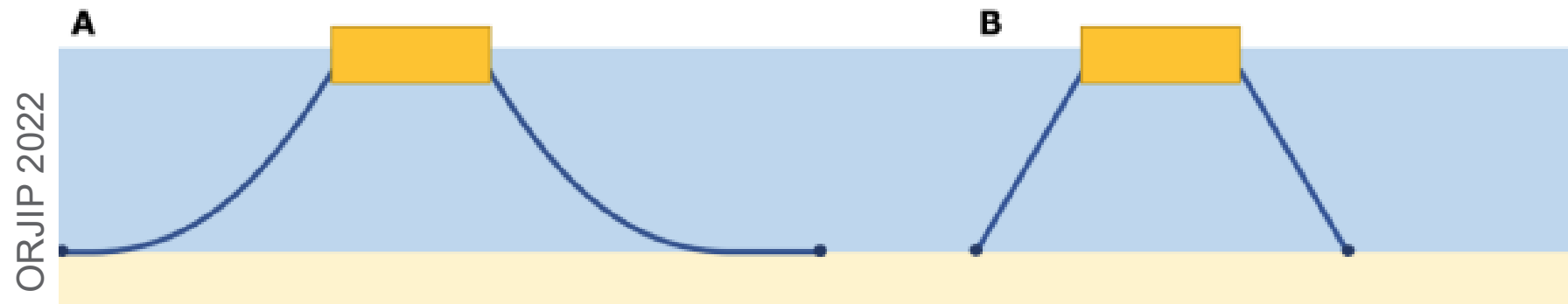

Common mooring system configurations: A) catenary, B) taut

4. Mooring system material and design

a. Marine energy specificities

- Lazy S mooring systems are a variation of catenary moorings, with flotation added to the line to take off some of the weight when very long mooring lines are required at depth.
- Taut mooring lines and tension leg moorings have increased stiffness and generally have a smaller seabed footprint than catenary moorings (EMEC, 2016).

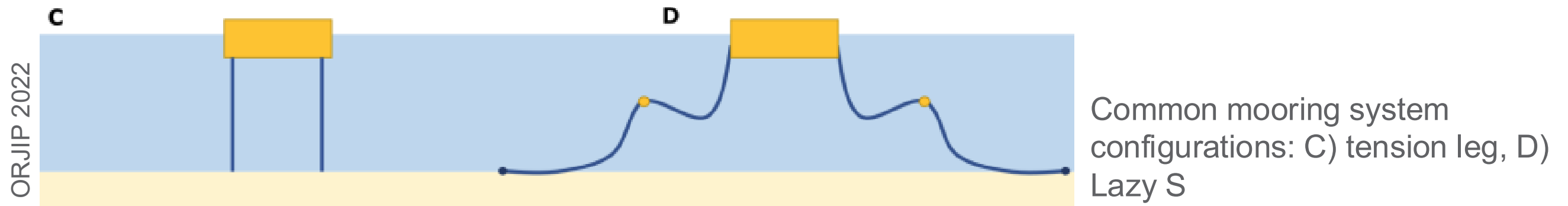

4. Mooring system material and design

a. Marine energy specificities

- Offshore mooring lines generally use chain, wire rope, and/or synthetic rope, although synthetic rope is most commonly used for WEC systems (Xu et al., 2019).
- This is because synthetic rope allows for increased tensioning, demonstrates lower fatigue under tension, enables less corrosion, and is cost effective (Xu et al., 2019).
- Sections of chains within catenary moorings provide additional weight and stability for marine energy systems but may be more expensive and require more maintenance (such as biofouling removal) than ropes (Maheen & Yang, 2023).



4. Mooring system material and design

a. Marine energy specificities

- A survey of 13 marine energy developers (9 wave, 3 tidal, 1 riverine energy) identified a diversity of mooring configurations, materials, and diameters.
- Chain was mostly used for catenary configurations and synthetic material for taut systems; a combination of synthetic ropes (or steel cable) and chain was also often used for catenary or catenary + taut configurations.
- The thinnest line diameter was 22 mm (polyester rope); the thickest was 200 mm (nylon rope).

Number of mooring lines				
1	2	3	4	5
15%	0%	38%	31%	8%

Mooring configuration				
Catenary	Taut	Catenary + taut	Tension leg	Lazy S
23%	46%	23%	0%	0%

Mooring material (sometimes in combination)			
Chain	Steel cable	Polyester rope	Nylon rope
62%	8%	38%	23%

Line diameter (sometimes in combination)			
< 50 mm	50-100 mm	100-150 mm	> 150 mm
54%	46%	8%	15%

Diversity of number of mooring lines, configuration, material, and diameter across 13 marine energy devices, expressed in percentages.

4. Mooring system material and design

b. Oceanographic instrument specificities

- Design, shape, and material of the mooring system for oceanographic instruments depend on the deployment duration and purpose, and environmental conditions such as depth, current, and wave conditions, as well as technical considerations such as deployment capabilities, budget, and personal preferences (Coppola et al., 2016; Venkatesan et al., 2018).
- Most commonly, oceanographic instruments are equipped with single-point mooring systems, though occasionally some long-term deployments may use spread moorings with two anchor lines.
- Mooring systems for surface oceanographic instruments are generally taut or catenary configurations, and can also include floats along the length of the line to ensure positive buoyancy, while subsurface instruments are usually on taut or semi-taut moorings.
- Although long-term deployments may use chains for added durability and stability, most oceanographic instruments use wire ropes and/or synthetic lines. Surface retrieval lines are commonly created using buoyant synthetic lines.

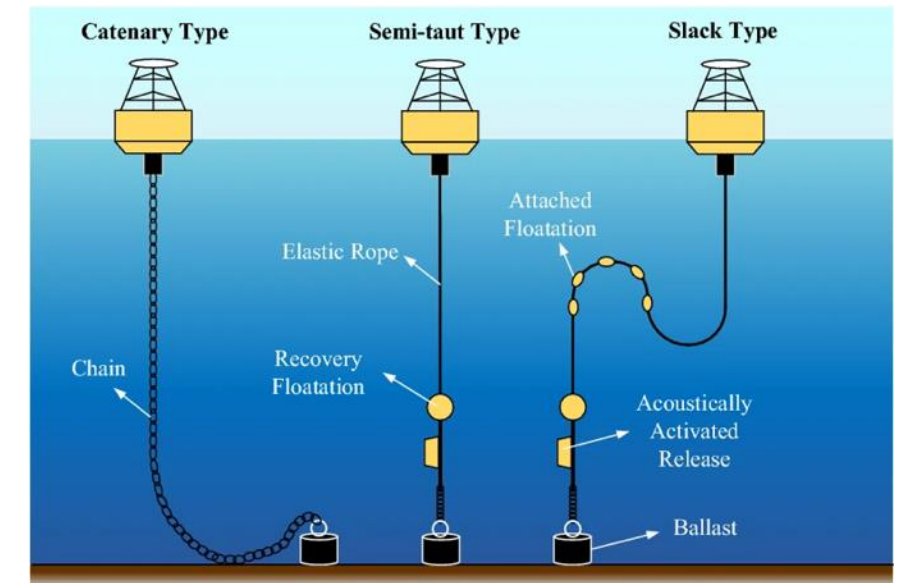

Common observation buoy mooring systems

5. Mooring system entanglement risk

- Entanglement risk with mooring systems varies depending on the physical characteristics of the system, including tension, loose ends, materials, movement of the system under various sea states (i.e., two-dimensional watch circle and three-dimensional swept volume), and curvature of the lines (Harnois et al., 2015).
- Catenary moorings (part laying on the seafloor, part suspended in the water column) are kept under fairly low tension and allow for flexibility in the system.
- Pre-tensioned lines that make up taut and tension moorings provide higher degree of tension and little flexibility, ensuring that mooring lines remain in place under various sea states (Harnois et al., 2015).
- Accessory buoys can be added at various parts of the lines to reduce the load of the mooring system on the floating structure (e.g., lazy S mooring configuration); however, this increases flexibility in the lines.

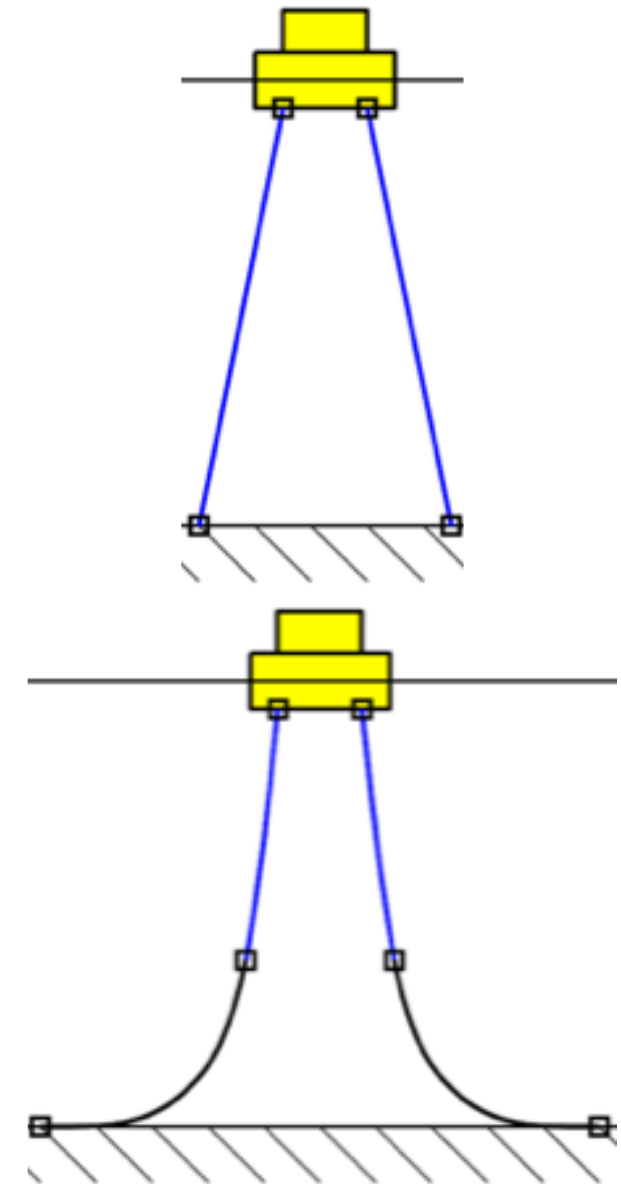

Schematic of taut-moored and catenary mooring systems with synthetic ropes and chains

5. Mooring system entanglement risk

- Harnois et al. (2015) calculated the entanglement risk for different mooring types using inputs that relate to the physical characteristics of the mooring, such as tension, swept volume, and curvature.

Entanglement risk assessment for different mooring types. Each parameter was scored on a scale from 1 to 3 (1 = lower relative risk, 3 = higher relative risk). The total entanglement risk score ranged from 3 to 9. (Source: Harnois et al. 2015)

Mooring type/risk parameters	Tension characteristics	Swept volume ratio	Curvature	Total score
Catenary & chains	2	2	2	6
Catenary & chains & nylon ropes	3	2	2	7
Catenary & chains & polyester ropes	2	2	2	6
Taut	1	1	1	3
Catenary & accessory buoy	3	2	2	7
Taut & accessory buoy	3	1	2	6

5. Mooring system entanglement risk

- Based on tension characteristics, the taut mooring configuration without accessory buoys had the lowest entanglement risk score, while catenary mooring with chains and nylon ropes, as well as catenary and taut moorings with accessory buoys, had the highest score.
- Considering the swept volume ratio of each mooring type, the entanglement risk score was lowest for taut mooring lines, both with and without accessory buoys.
- Accessory buoys increases the curvature of the mooring line, therefore increasing relative entanglement risk of moorings.
- Overall entanglement risk was determined for each mooring type using these scores.
- The highest risk (7) was associated with catenary moorings with chains and nylon ropes, and catenary moorings with accessory buoys.
- Moderate scores (6) were given to catenary moorings with chains and polyester ropes, and catenary moorings with chains only, as well as the taut mooring with accessory buoys.
- The lowest risk score (3) was assigned to the taut mooring configuration with no accessory buoys (Harnois et al., 2015)

6. Animals at risk and their specificities

- The marine animals most likely to be at risk of entanglement in the mooring lines or cables of marine energy devices and/or oceanographic instruments are large animals (megafauna) that tend to move slowly, don't maneuver very well, or spend a lot of time at the surface and/or near artificial structures for food or shelter.
- Examples include large whales, sea turtles, or ocean sunfish.

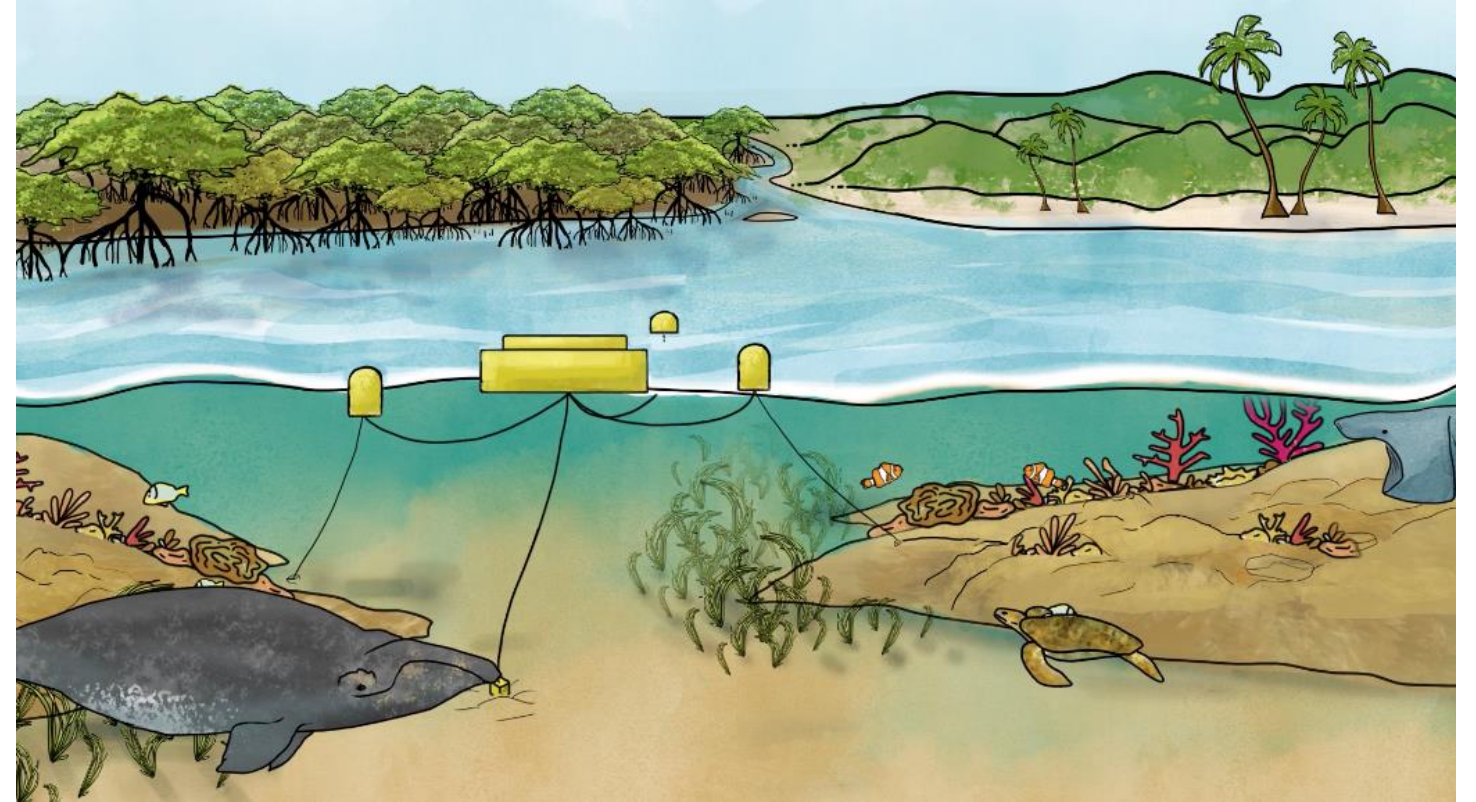

6. Animals at risk and their specificities

a. Distribution – Cetaceans

- Cetaceans can occupy a variety of habitat types depending on the time of year, migration patterns, foraging areas, and breeding areas.
- For example, the north Atlantic right whale (*Eubalaena glacialis*) primarily live in Atlantic coastal waters on the continental shelf, however they do also travel farther offshore into deep water (NOAA Fisheries, 2025t).
- Generally, they can be found north off the coast of New England or into Canada, their known foraging areas, but they also migrate to shallower water off the southern east coast states for breeding.
- Right whales can often be observed near the surface, socializing in groups (NOAA Fisheries, 2025t).

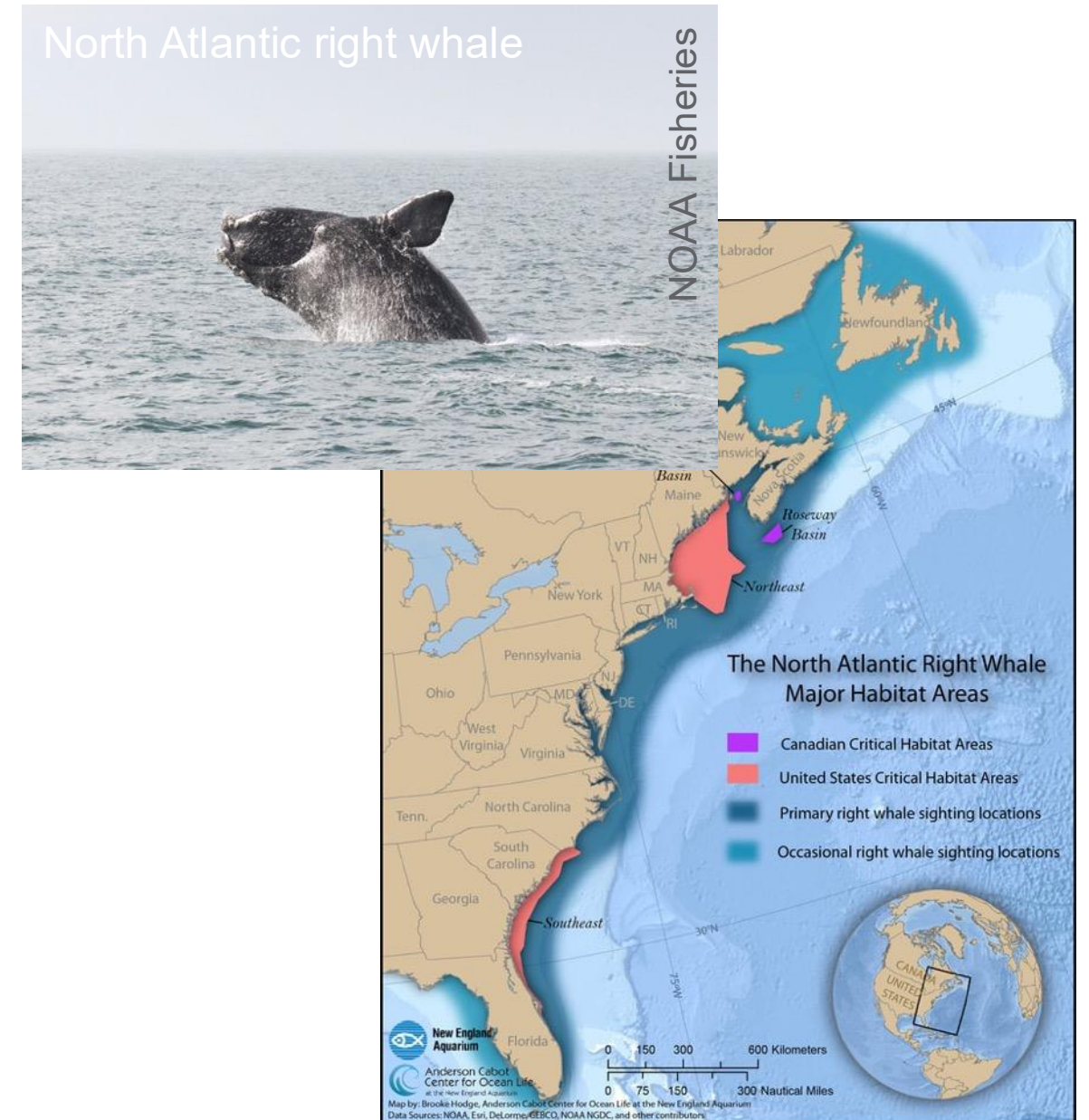

6. Animals at risk and their specificities

a. Distribution – Cetaceans

- Humpback whales (*Megaptera novaeangliae*) are found in all major oceans.
- They can be observed in both deep and shallow waters, preferring warmer, shallow water for calving, and colder water for feeding both in deep and shallow water, requiring sometimes extensive migration between seasons.
- They can be observed close to the shore and near the surface (NOAA Fisheries, 2025p).
- Other whales, for example, the sperm whale (*Physeter macrocephalus*) are found in deep ocean waters around the world, diving deep below the surface to hunt for food (NOAA Fisheries, 2025k).

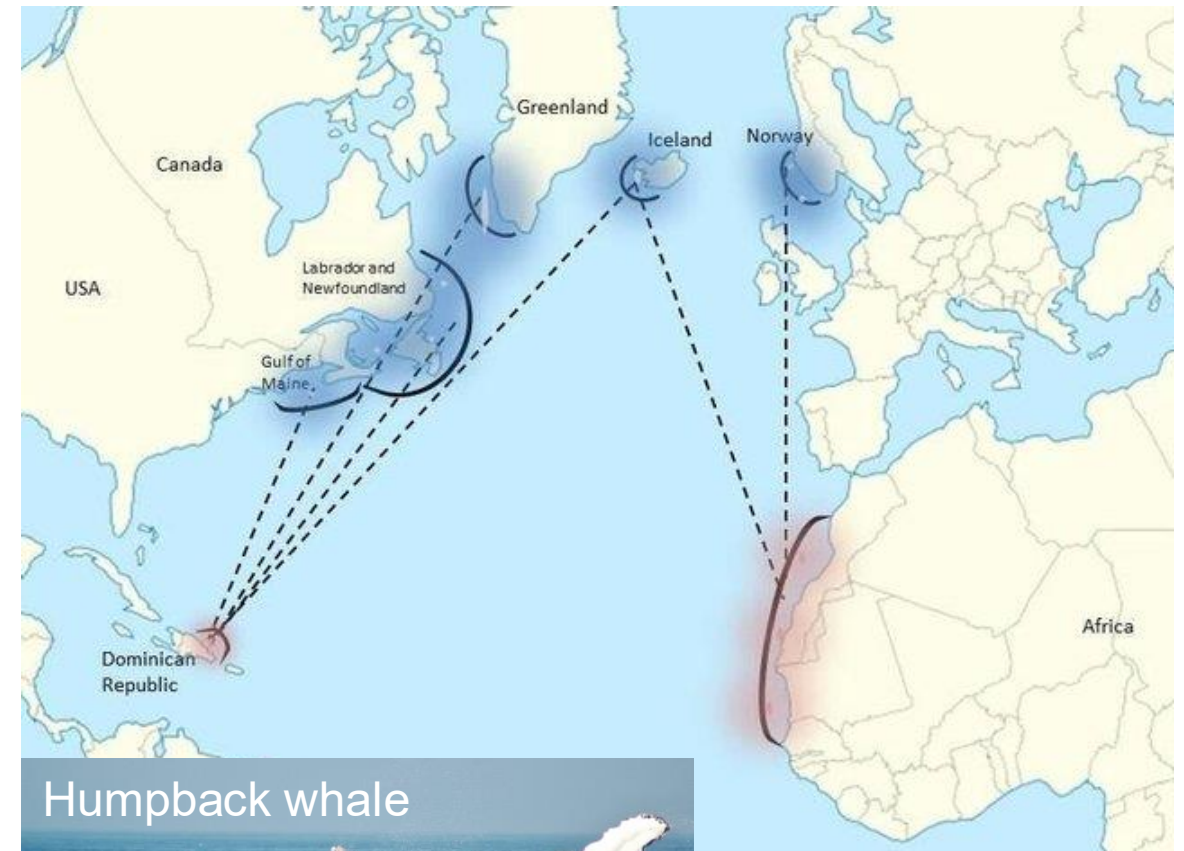

NC Sea Grant

6. Animals at risk and their specificities

a. Distribution – Cetaceans

- Smaller cetaceans, such as harbor porpoises (*Phocoena phocoena*) and bottlenose dolphins (*Tursiops truncatus*), are found in both temperate and tropical waters, and can inhabit a variety of nearshore coastal habitats such as bays, harbors, gulfs, and estuaries (NOAA Fisheries, 2025c, 2025e).
- Bottlenose dolphins can also be found in offshore, deeper water.
- These dolphins can be seen exhibiting social behaviors and curiosity at the surface.
- Harbor porpoises, on the other hand, can be shy and hesitant to approach objects or surface near boats (NOAA Fisheries, 2025c).



NOAA Fisheries



NOAA Fisheries

6. Animals at risk and their specificities

a. Distribution – Pinnipeds

- Pinnipeds, such as harbor seals (*Phoca vitulina*) and gray seals (*Halichoerus grypus*), inhabit coastal waters.
- Gray seals are found along the north Atlantic coast, and harbor seals along both East and West coasts of the U.S. (NOAA Fisheries, 2025i, 2025j).
- Both harbor and gray seals can be found traveling or foraging in deeper water; however, most of the time, they gather in groups to haul out on rocky shores or beaches (NOAA Fisheries, 2025c, 2025i).



6. Animals at risk and their specificities

a. Distribution – Sirenians

- The only sirenian present in the U.S. is the West Indian manatee (*Trichechus manatus*), consisting of two subspecies: Florida manatee and Antillean manatee.
- West Indian manatees can be found along the Atlantic and Gulf coasts, moving around throughout the year as they are intolerant to cold water (U.S. Fish & Wildlife Service, 2025b).
- They are generally found in nearshore areas, particularly those that include aquatic vegetation, such as seagrass and eelgrass.
- They also need to surface for air regularly, only able to hold their breaths for up to 20 minutes (U.S. Fish & Wildlife Service, 2025b).



National Marine Sanctuary
Foundation



6. Animals at risk and their specificities

a. Distribution – Sea Turtles

- The coasts of the U.S. inhabits multiple species of sea turtles.
- Green sea turtles (*Chelonia mydas*) and loggerhead (*Caretta caretta*) sea turtles are found in the Atlantic, Pacific, and Gulf coasts (NOAA Fisheries, 2025m, 2025q).
- Juveniles spend the first phase of their lives in the open ocean, before traveling to shallow coastal water to foraging grounds.
- Adult green and loggerhead turtles migrate, sometimes great distances, from their nearshore foraging grounds, to nesting beaches to lay eggs (NOAA Fisheries, 2025m, 2025q).

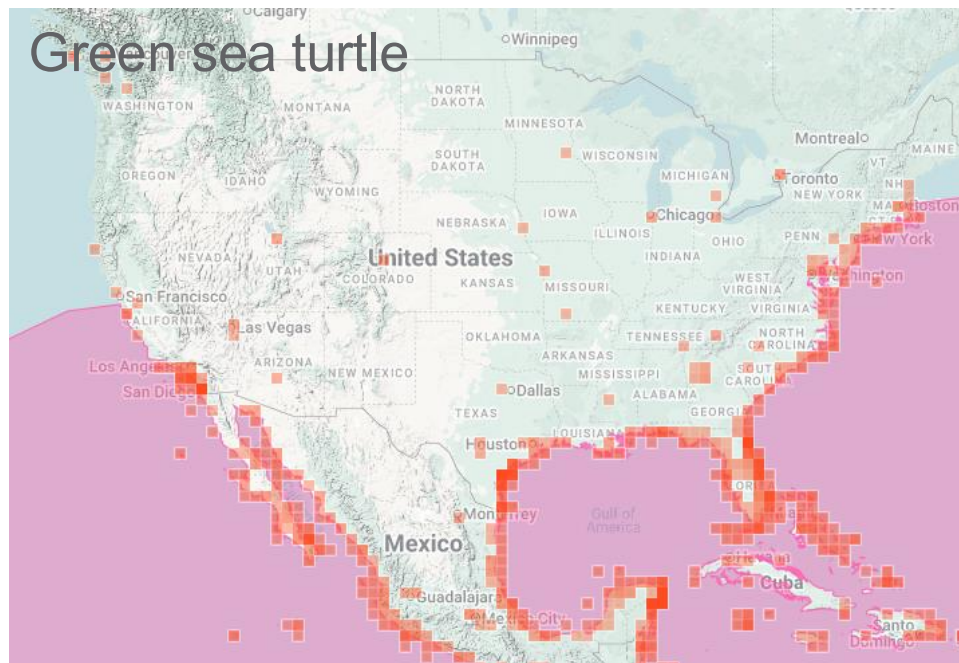

NOAA Fisheries

iNaturalist



The Nature Conservancy

6. Animals at risk and their specificities

a. Distribution – Sea Turtles

- Leatherback sea turtles (*Dermochelys coriacea*) are found in deep waters off the Atlantic, Pacific, and Gulf coasts, but their primary nesting beaches in the U.S. are in Florida, Puerto Rico, and the U.S. Virgin Islands (NOAA Fisheries, 2025s).
- Leatherback turtles spend most of their time offshore and can undertake long migrations between foraging and breeding grounds (NOAA Fisheries, 2025s).



NOAA Fisheries

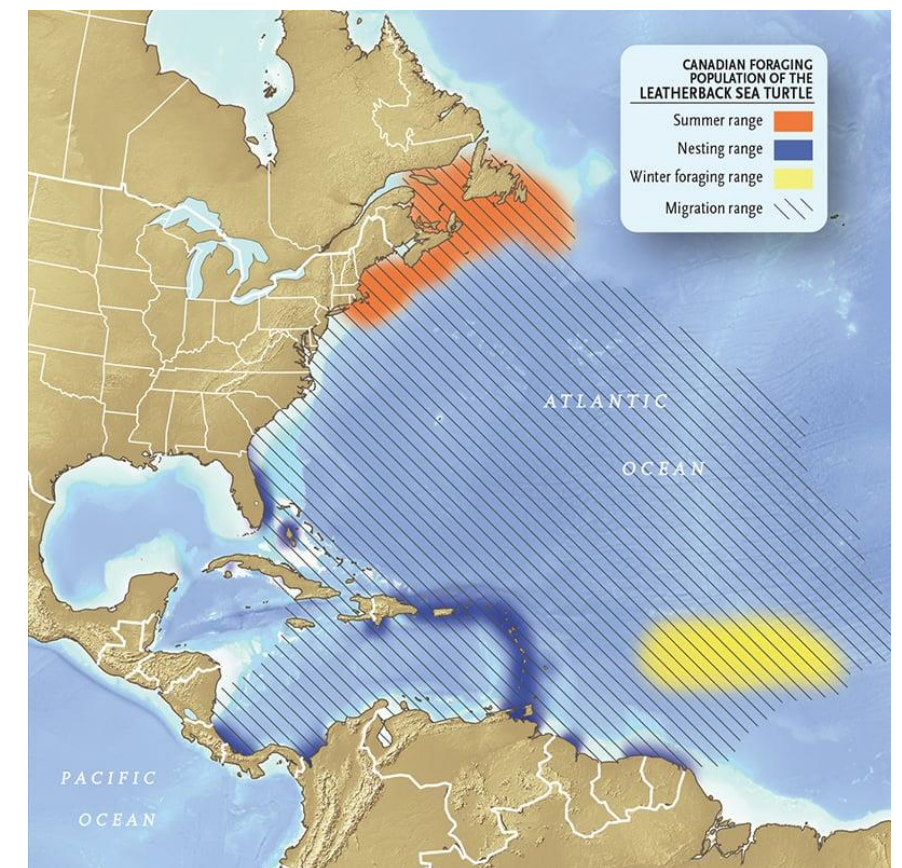

Canadian Geographic

6. Animals at risk and their specificities

a. Distribution – Sea Turtles

- Kemp's ridley sea turtles (*Lepidochelyys kempii*) are found primarily along the Gulf coast and the U.S. Atlantic coast from Florida to New England.
- Juveniles travel offshore, drifting for the first few years as they grow, then migrating to nearshore habitats to feed (NOAA Fisheries, 2025I).
- Adult females migrate to land to lay eggs, however unlike the green, loggerhead, and leatherback turtles, they engage in group nesting in which large groups gather offshore and then travel to the beach all at once (NOAA Fisheries, 2025I).



Ocean Conservancy

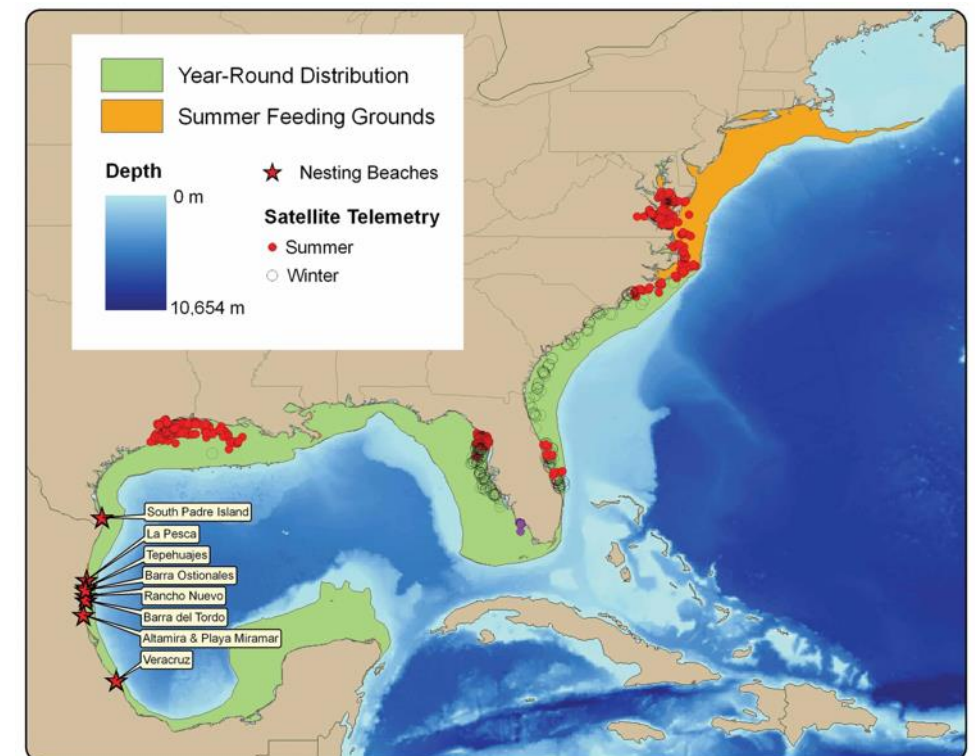

6. Animals at risk and their specificities

a. Distribution – Elasmobranchs

- More than 50 species of sharks are found along the Atlantic coast of the U.S., many of which spend at least some of their time in coastal nearshore waters, at either foraging or nursing grounds (NOAA Fisheries, 2025b).
- Basking sharks (*Cetorhinus maximus*) are migratory species that can be found in both deep and nearshore coastal waters.
- They are usually observed feeding on plankton near the surface, but can also dive to significant depths (BOEM, 2024).

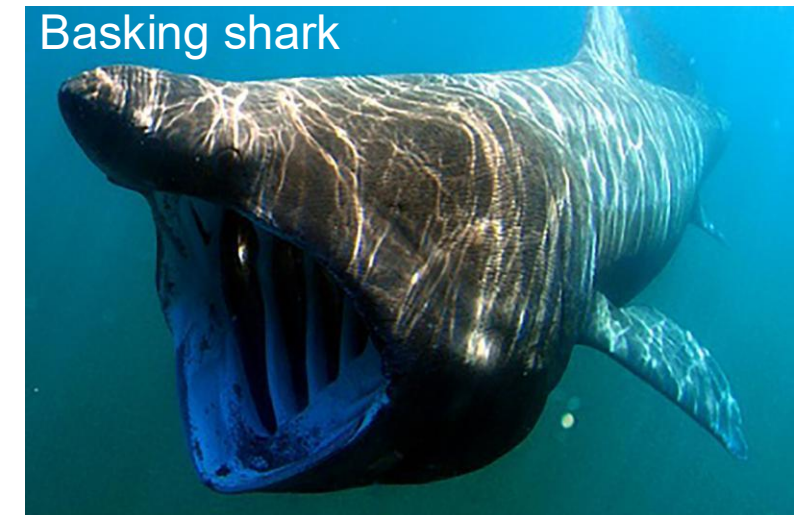

NOAA Fisheries

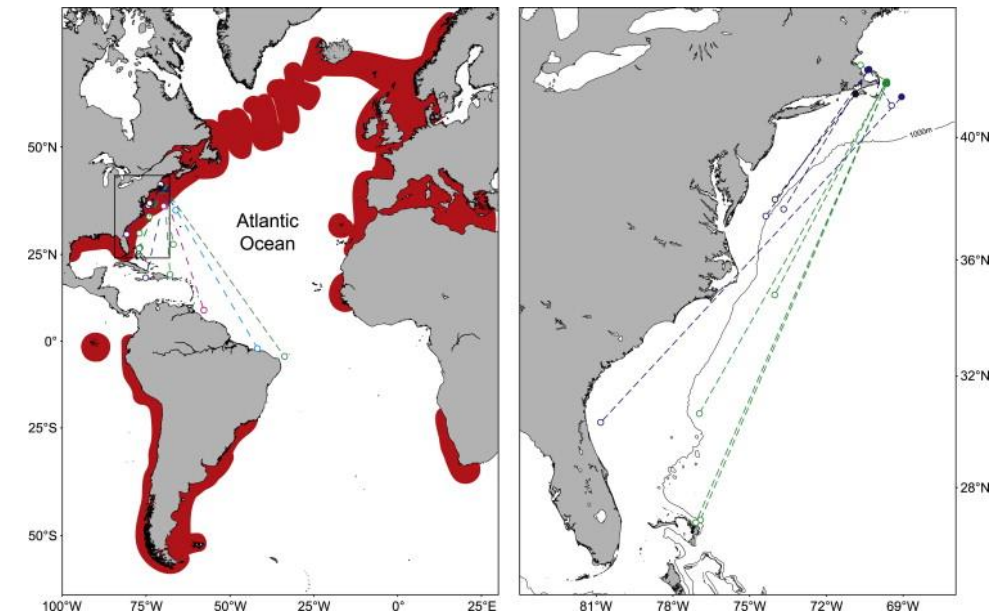

Skomal et al. 2009

6. Animals at risk and their specificities

a. Distribution – Elasmobranchs

- Atlantic blacktip sharks (*Carcharhinus limbatus*) are found more commonly in the Gulf and around Florida, but can be spotted migrating as far north as Massachusetts (NOAA Fisheries, 2025a, 2025r).
- Blacktip sharks primarily inhabit the continental shelf and can be found off beaches and in bays (NOAA Fisheries, 2025r).
- Great white sharks (*Carcharodon carcharias*) are migratory animals present in all U.S. temperate and subtropical waters, in both nearshore coastal waters and offshore pelagic waters.
- Juveniles tend to remain nearshore in warmer waters and, as they age, they split their time between pelagic waters and nearshore hunting grounds (NOAA Fisheries, 2025a).

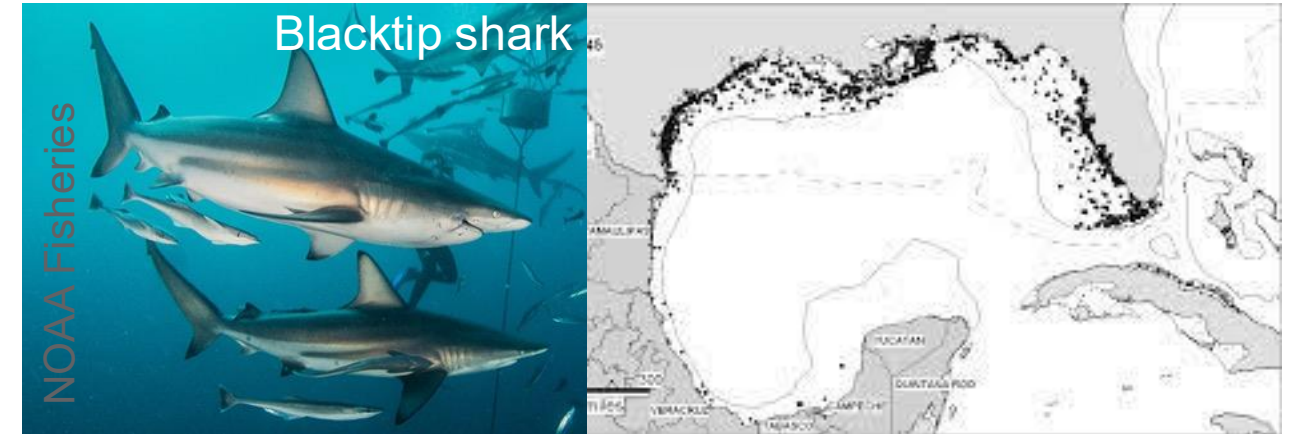

Swinsburg et al. 2012

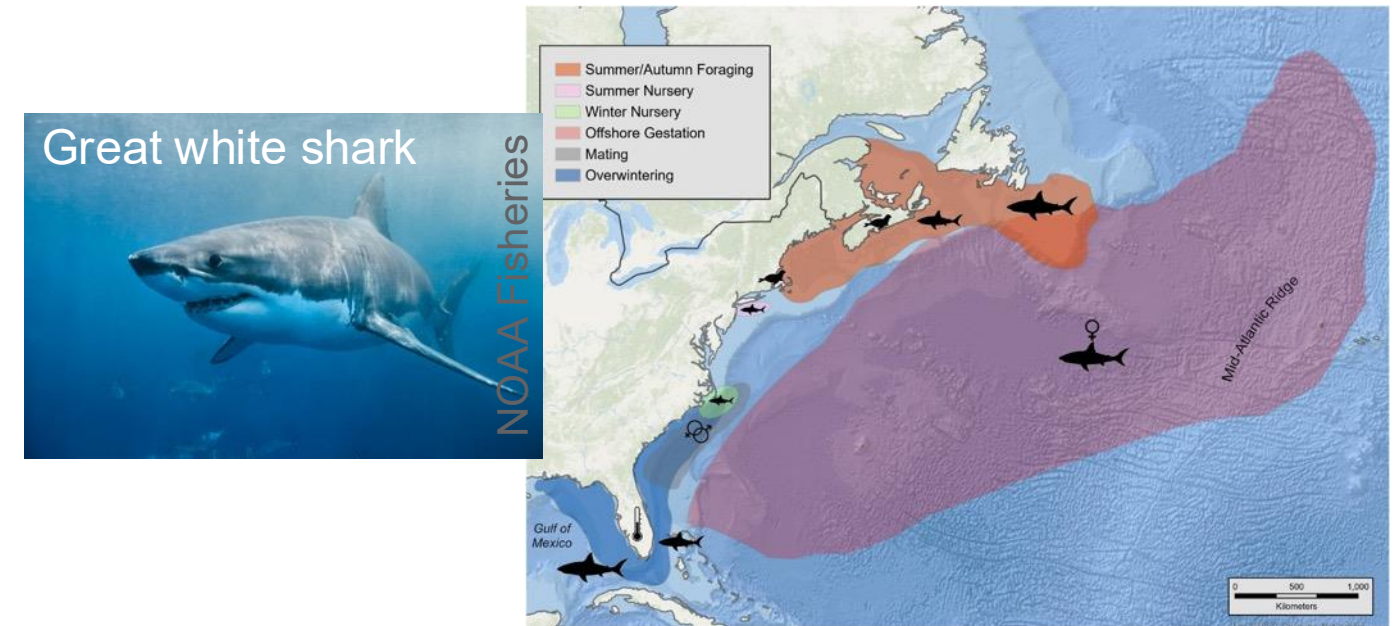

Franks et al. 2021

6. Animals at risk and their specificities

a. Distribution – Large fish

- The largest teleost fish, the ocean sunfish (*Mola mola*), can be found in the U.S. off both the Atlantic and Pacific coasts (oceansunfish.org, n.d.).
- Based off of satellite tagging data, sunfish can be found in the Gulf of Maine and New England during the spring and summer months and move south along the continental shelf break towards Florida and the Gulf at the end of summer (Potter, 2010).
- Ocean sunfish largely inhabit deeper offshore waters; however, they do travel nearshore to shallower, warmer waters, particularly those found along the coasts of the in northern states (Potter, 2010).

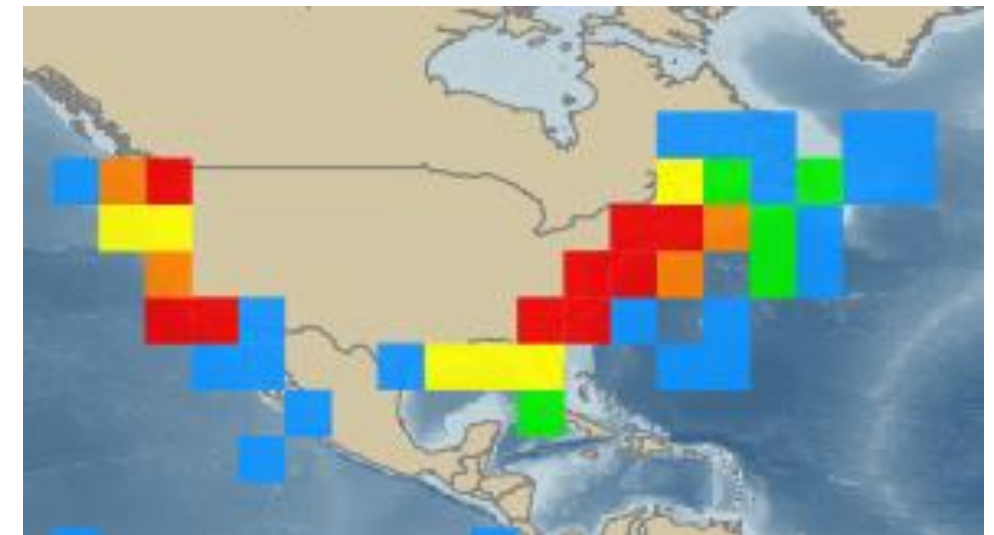

6. Animals at risk and their specificities

a. Distribution – Large fish

- Other large fish present along the U.S. Atlantic coast include swordfish, billfish and tuna species, such as the Atlantic bluefin tuna (*Thunnus thynnus*) and the North Atlantic swordfish (*Xiphias gladius*) (NOAA Fisheries, 2025o).
- Bluefin tuna are found along the east coast, ranging from Canada to the Gulf coast.
- They primarily live near the surface, but do frequently dive in deeper waters (NOAA Fisheries, 2025g).
- Bluefin tuna are highly migratory species, but usually return to the Gulf to spawn (NOAA Fisheries, 2025g).
- Swordfish can be found in the Gulf Stream of the western north Atlantic, and live both in surface and mid-water column areas.
- Swordfish are migratory animals, moving between warm waters for spawning and colder waters for feeding (NOAA Fisheries, 2025f).



NOAA Fisheries



WHOI

6. Animals at risk and their specificities

b. Maneuverability

- Maneuverability varies per species depending on body shape, size, and skeletal structure.
- The table provides an overview of the relative flexibility of various marine animal groups, associated with their potential risk of entanglement due to limits in maneuverability.
- More details about animal maneuverability are provided in the following slides.

Body flexibility of different megafauna groups
(Source: Benjamins et al., 2014)

Species group			Entanglement risk based on body flexibility: Relatively flexible = 1 Relatively rigid = 2
Cetaceans	Baleen whales	Large whales	2
		Medium-sized whales	2
	Toothed whales	Sperm whale	2
		Medium-sized whales and dolphins	2
		Small whales, dolphins and porpoises	2
Pinnipeds	Seals		1
	Sea lions, fur seals etc.		1
Sea turtles			2
Sharks	Basking sharks		1
	Other large sharks		1
Ocean sunfish			2

6. Animals at risk and their specificities

b. Maneuverability – Cetaceans

- Cetaceans share several morphologic features associated with increased hydrodynamic performance, including streamlined bodies, oscillation of caudal flukes for propulsion, and hydrodynamic flippers (Weber et al., 2014).
- Smaller cetaceans have the advantage of faster turning rates and shorter turn radius compared to larger bodied cetaceans (Howland, 1974).
- Cetaceans that have flexible bodies and mobile flippers sacrifice speed for increased maneuverability, while species with stiffer morphologies are faster but less maneuverable with a higher turn radius (Fish, 1997).
- Body shape and body features determining swimming behavior and maneuverability have evolved over time based on feeding requirements and habitat considerations (Fish, 2002; Woodward et al., 2006).

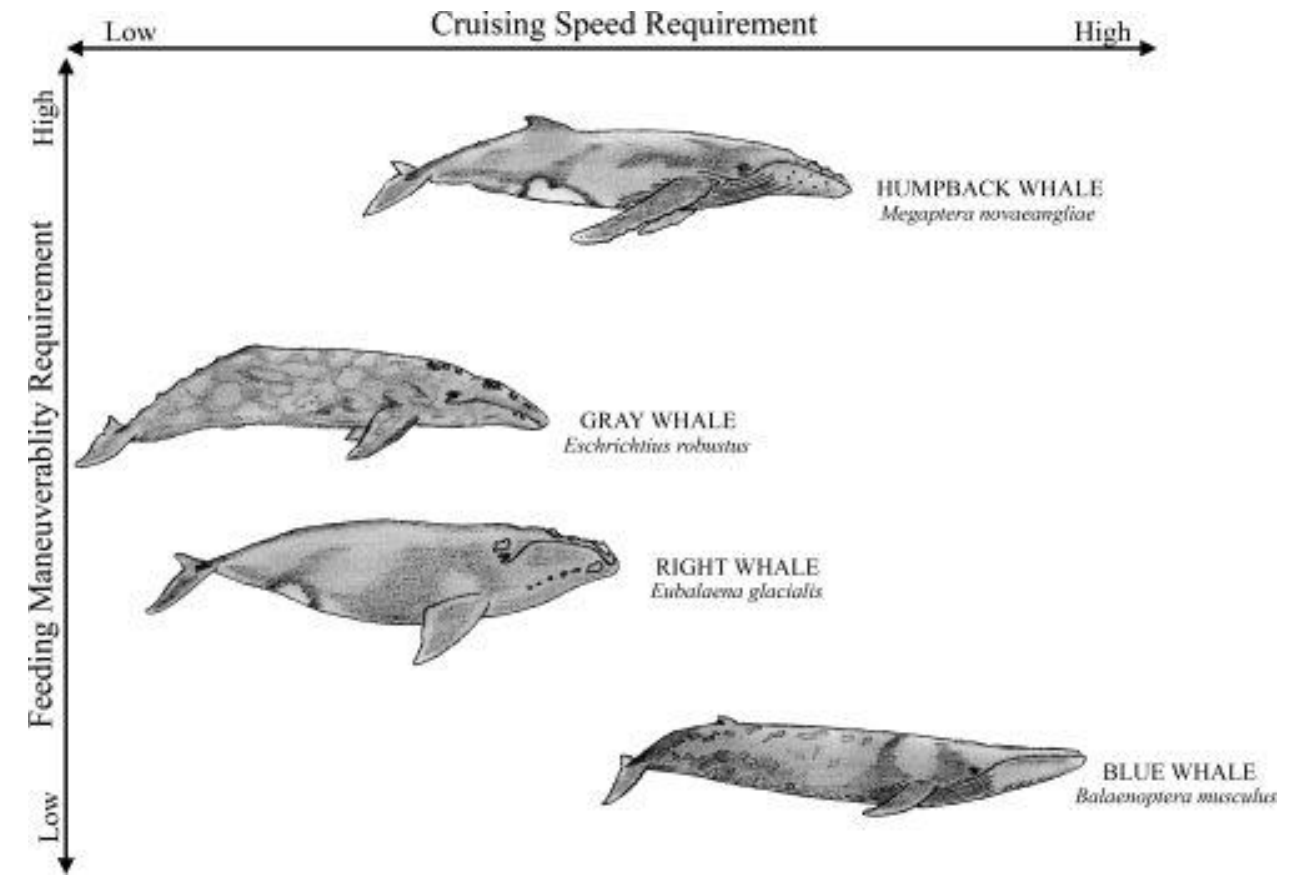

Body form for selected baleen whale species ranked on cruising speed and maneuverability requirements

6. Animals at risk and their specificities

b. Maneuverability – Pinnipeds

- Pinnipeds, like the California sea lion (*Zalophus californianus*), exhibit a small turning radius, even at high swim speeds (Fish, 1997).
- Pinnipeds have highly flexible bodies and flippers that aid in increasing maneuverability and quick turning (Fish, 1997).
- The streamlined shape of a harbor seal's body and small non-rotatable flippers allows for increased swimming efficiency and high agility (Zier & Gaydos, 2014).

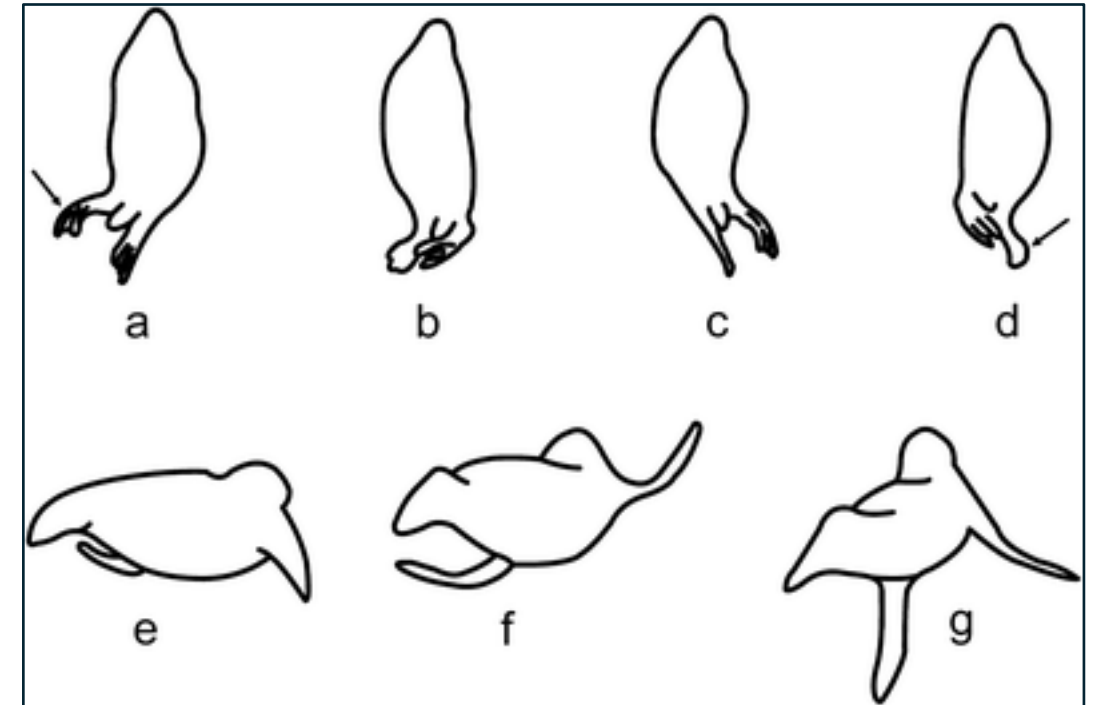

Kuhn & Frey 2012

Aquatic locomotion of seals and fur seals. a–d lateral undulation, dorsal view of a seal: power stroke by left hind fin (arrow) with abducted toes (a–c) and change to right hind fin with new power stroke (arrow) (d). e–g underwater flight, caudal view of a fur seal: recovery (e), paddle phase (f), and power phase (g).

6. Animals at risk and their specificities

b. Maneuverability – Sirenians

- Manatees are slow swimmers generally; however, they can exhibit small bursts of speed when threatened (Kojeszewski & Fish, 2007).
- They swim by undulation with their bodies and paddle-like flukes, a relatively lower efficiency method than that of cetaceans (Kojeszewski & Fish, 2007).
- Feeding manatees are less likely to change their behavior when disturbed such as a passing boat; however, when swimming in a traveling state, they are much more likely to respond to the stimulus and change direction (Rycyk, 2013).

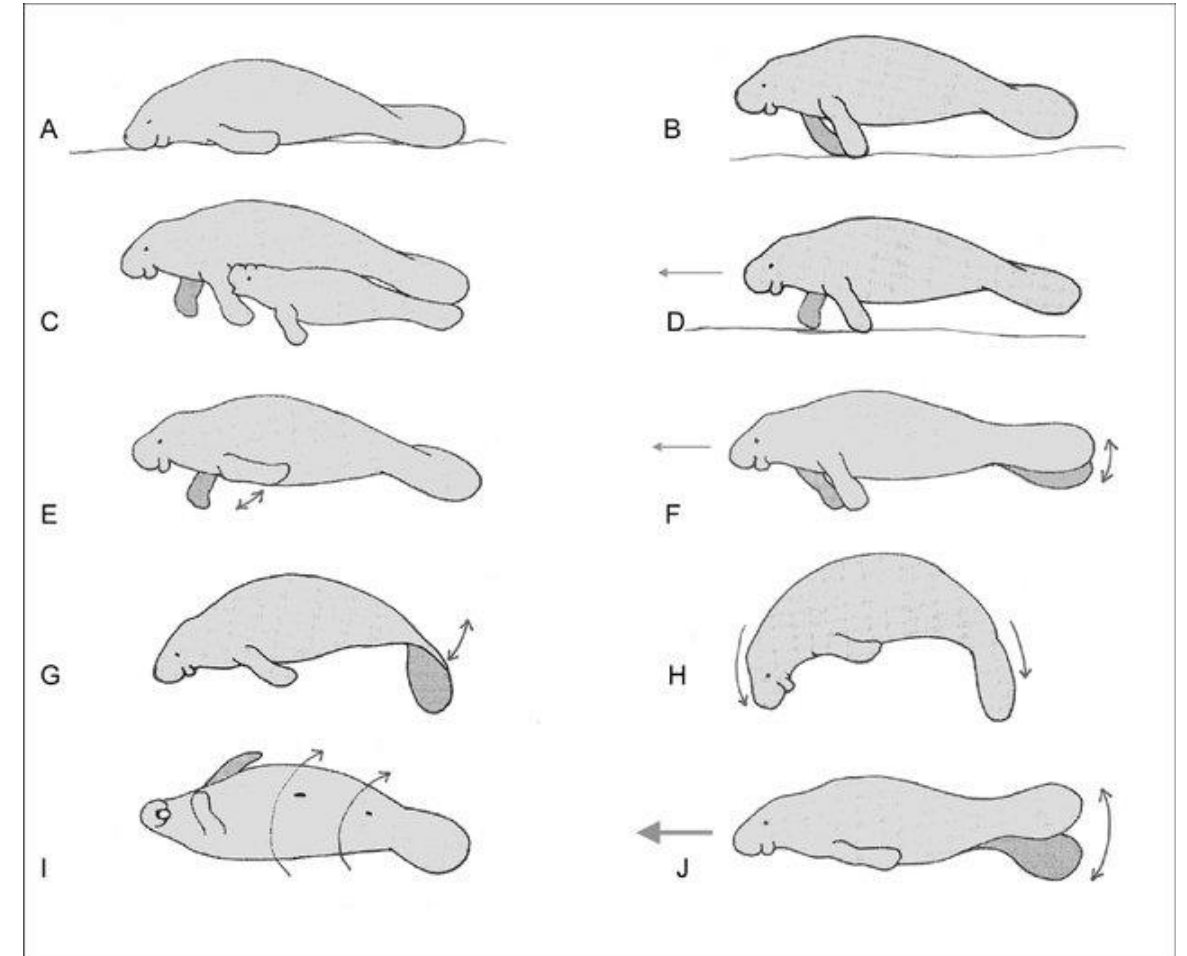

Florida manatee behaviors, from resting (A) to fast swimming (J)

6. Animals at risk and their specificities

b. Maneuverability – Sea turtles

- All sea turtles have streamlined bodies that limit drag and facilitate long distance swimming, and flippers that produce thrust (Lutz et al., 2002).
- The spine and ribs of sea turtles are fused to their carapace, making their bodies rigid; their fore- and hindlimbs are thus responsible for locomotion and maneuvering (Lutz et al., 2002; Rivera, 2009).
- Green turtle's forelimbs act like wings, generating a strong propulsive force that allows for highly efficient swimming (Davenport et al., 1984).

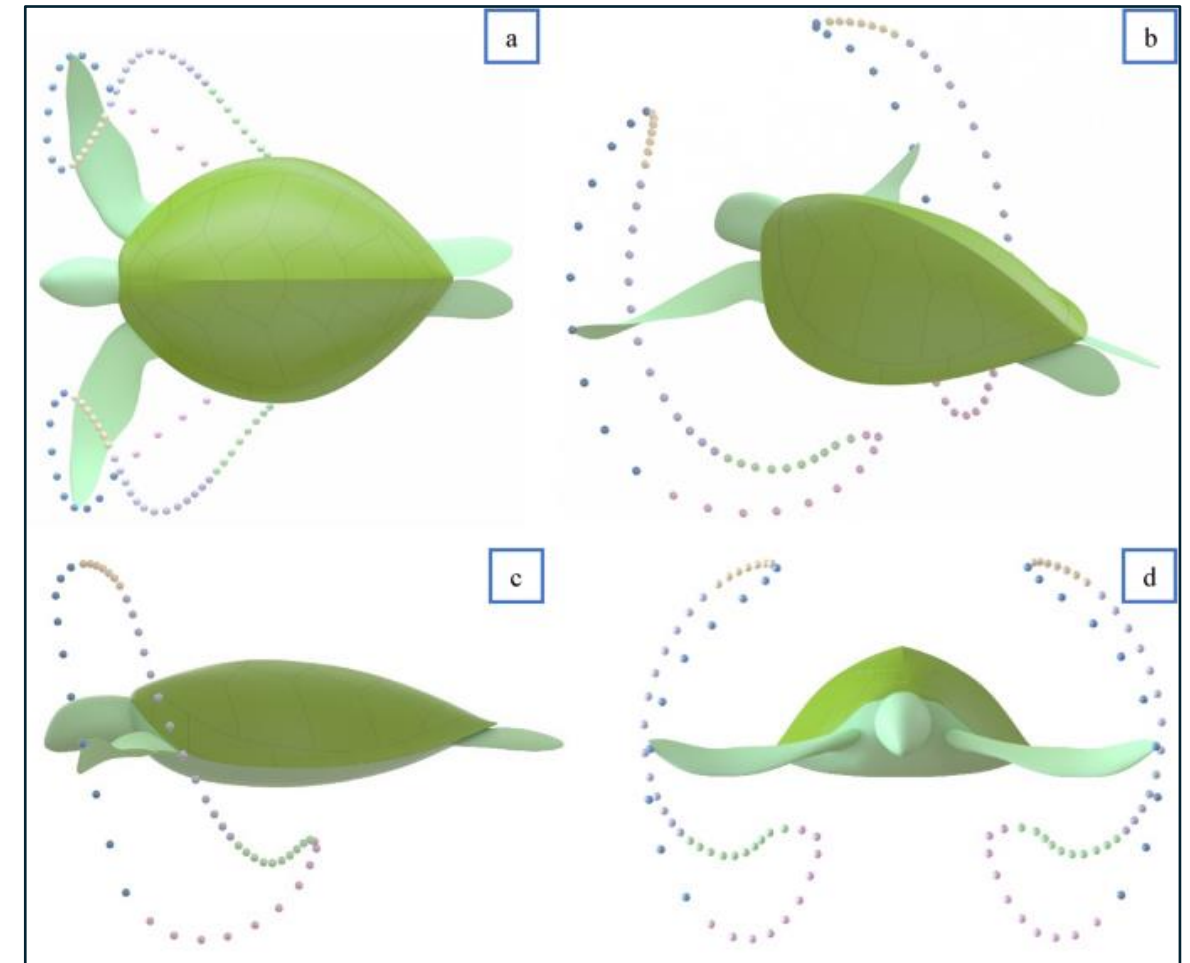

Flipper motion of a swimming green sea turtle

6. Animals at risk and their specificities

b. Maneuverability – Elasmobranchs

- Large pelagic species, such as the basking shark, great white shark, Atlantic shortfin mako, and blacktip shark, come in a variety of shapes and sizes.
- Most sharks have elongated, streamlined bodies in a fusiform shape that reduce drag and allow for efficient swimming, while flexibility of the body enables quick turning movements (Thomson & Simanek, 1977; Wilson & Wilding, 2017).
- Basking sharks are relatively slow swimmers, even more so when filter feeding with their mouths open (Sims, 2000).

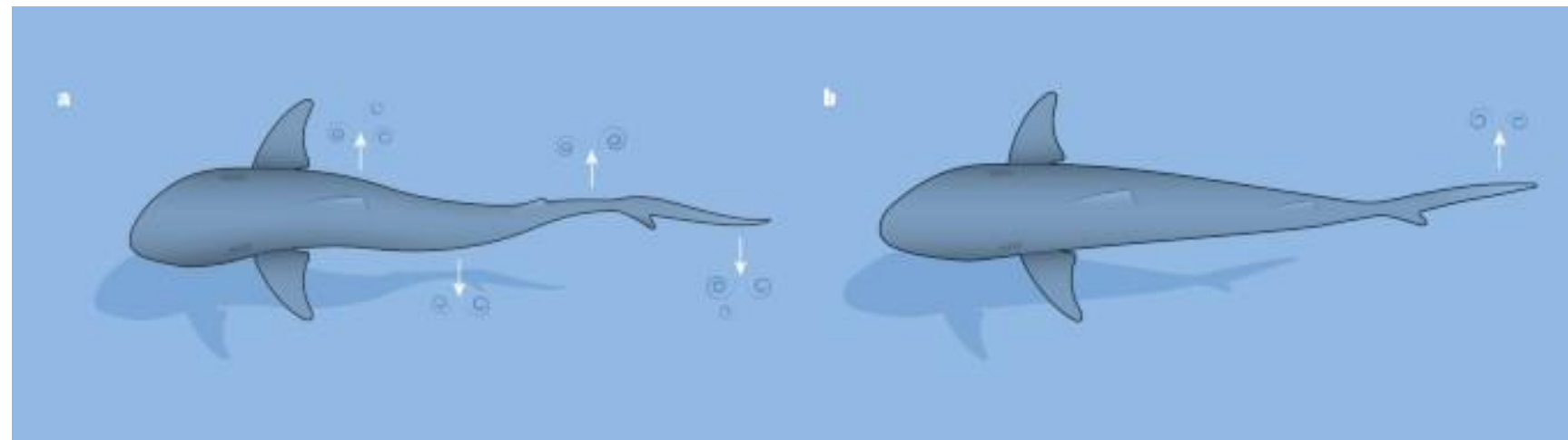

Kolmann & Summers
2016

Shark spine stiffness and swimming efficiency

6. Animals at risk and their specificities

b. Maneuverability – Large fish

- Despite their large size, ocean sunfish have been observed to be active swimmers, exhibiting highly directional movement (Cartamil & Lowe, 2004).
- Ocean sunfish use both their anal fin and dorsal fin in a “flapping” motion to generate a forward thrust (Pope et al., 2010).
- Other species of large fish, such as tunas, swordfish, and billfish have streamlined bodies for quick movement through the water (NOAA Fisheries, 2025d, 2025f, 2025g).
- While these fish are fast swimmers, their round body shape makes them not particularly flexible (Shadwick et al., 2013).

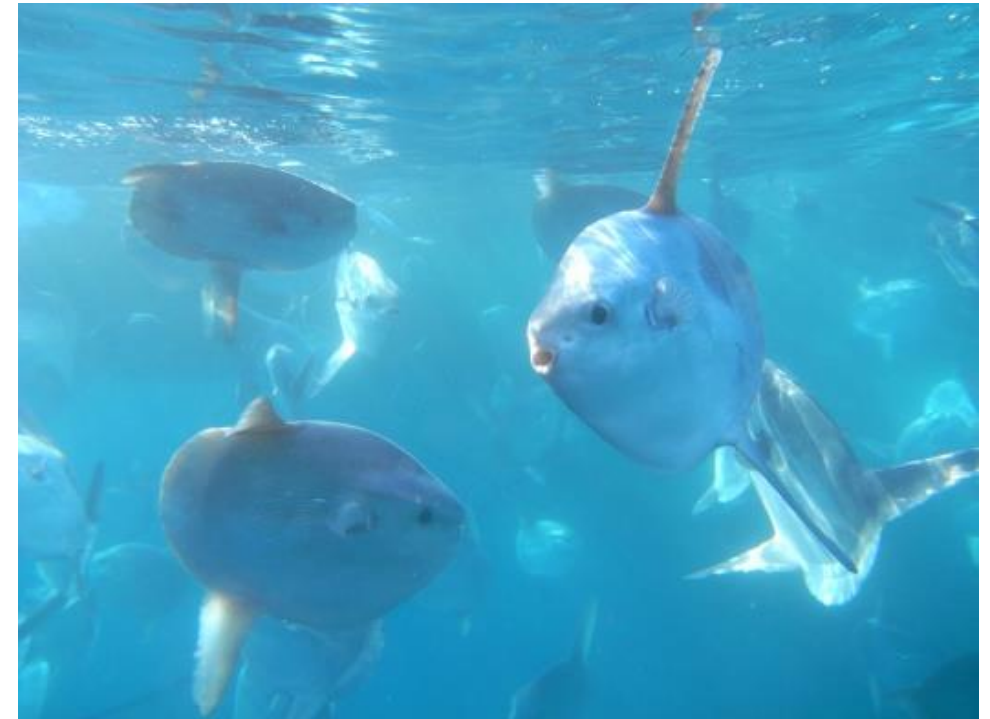

6. Animals at risk and their specificities

c. Detection capabilities

- Different animal groups have a variety of detection capabilities adapted to their habitat, environmental conditions, body size, and evolutionary history.
- The general sensory capabilities of marine megafauna groups are summarized in the table.

Marine megafauna detection capabilities related to mooring lines

Species group		Ability to accurately detect object at distances of: >10 body lengths = 1 1-10 body lengths = 2	Likely main sensory modality used at close range	
Cetaceans	Baleen whales	Large whales	2	Vision, hearing
		Medium-sized whales	2	Vision, hearing
	Toothed whales	Sperm whale	1	Active acoustics (echolocation), vision
		Medium-sized whales and dolphins	1	Active acoustics (echolocation), vision
	Small whales, dolphins and porpoises	1	Active acoustics (echolocation), vision	
Pinnipeds	Seals	2	Mechanoperception, vision, hearing	
	Sea lions, fur seals etc.	2	Mechanoperception, vision, hearing	
Sea turtles		2	Vision, hearing	
Sharks	Basking sharks	2	Mechanoperception, electroperception, vision	
	Other large sharks	2	Mechanoperception, electroperception, vision	
Ocean sunfish		2	Mechanoperception, vision	

6. Animals at risk and their specificities

c. Detection capabilities – Cetaceans

- Cetaceans' wavelength sensitivity is blue-shifted and suited for low light levels, with maxima at 483 nm for sperm whales, 496 nm for gray whales, and 488 nm for bottlenose dolphins (McFarland, 1971).
- While cetaceans have limited color vision, colors that contrast strongly with the blue of the ocean, such as red, orange, and white, might allow for increased detection of colored submerged objects (Kot et al., 2012; Kraus et al., 2014).
- Dolphins have poor visual acuity in the range of 10 to 20 min of arc, a measurement of an animal's ability to perceive details at a distance (Griebel & Peichl, 2003).
- Echolocation is the toothed whales' additional detection capability, the ability to emit and detect sound waves to perceive objects in their environment.
- For instance, harbor porpoise are able to detect submerged gillnets over 80 m away (Nielsen et al., 2012).



Simulation of minke whales' greyscale vision at 5-m depth: A = black, B = blue, C = green, D = yellow, E = orange, F = white

6. Animals at risk and their specificities

c. Detection capabilities – Cetaceans

- Low frequency cetaceans, like baleen whales, have a hearing range from 7 Hz to 36 kHz, high frequency cetaceans like dolphins and toothed whales from 150 Hz to 160 kHz, and very high frequency cetaceans like true porpoises and river dolphins from 200 Hz to 165 kHz (National Marine Fisheries Service 2024a).
- Cochlear formats and frequency ranges in cetaceans are related to their habitats and feeding behaviors.
- Type 1 cochlear formats are found in inshore porpoises and river dolphins, where they live in turbid waters and use high frequency signals for analyzing fine details.
- Type 2 cochlear formats are found in offshore and pelagic dolphin species and have better mid to low range hearing than type 1 ears; type 2 ears are consistent with social species that rely on resolving predators and prey at greater distances (Ketten 2000).

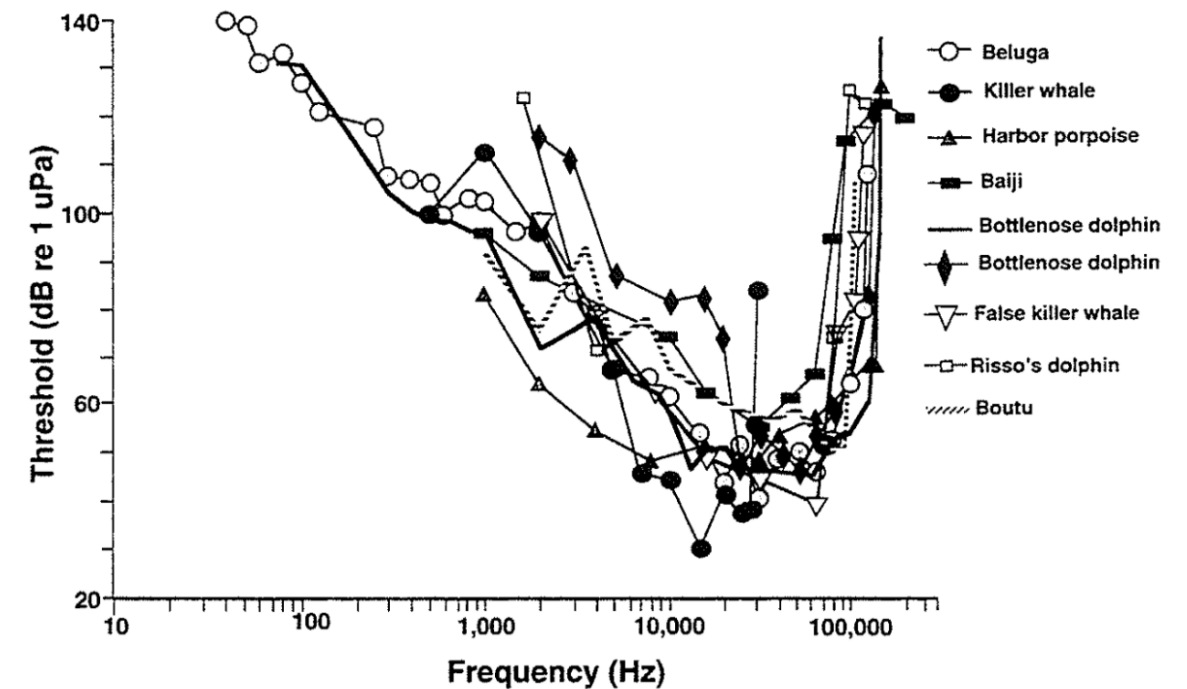

Hearing ranges and peak frequencies of various species of toothed whales

6. Animals at risk and their specificities

c. Detection capabilities – Pinnipeds

- Pinnipeds possess mechanoreception abilities, particularly through the vibration of their whiskers.
- The ability to detect water movement due to submerged objects or organisms is known as hydrodynamic perception (Hanke et al., 2013) and has been experimentally observed in harbor seals (Dehnhardt et al., 1998).
- Pinniped visual acuity falls within the range of 5 to 9 minutes of arc for underwater vision (Schusterman, 1972), relatively poor visual acuity compared to land animals, some of which have acuity under 1 arc minute.
- Underwater hearing ranges for true seals to span six octaves (Reichmuth et al. 2013).
- The general underwater hearing range for true seals (phocids) is 40 Hz to 90 kHz, and 60 Hz to 68 kHz for sea lions and fur seals (otariids) (National Marine Fisheries Service 2024a).

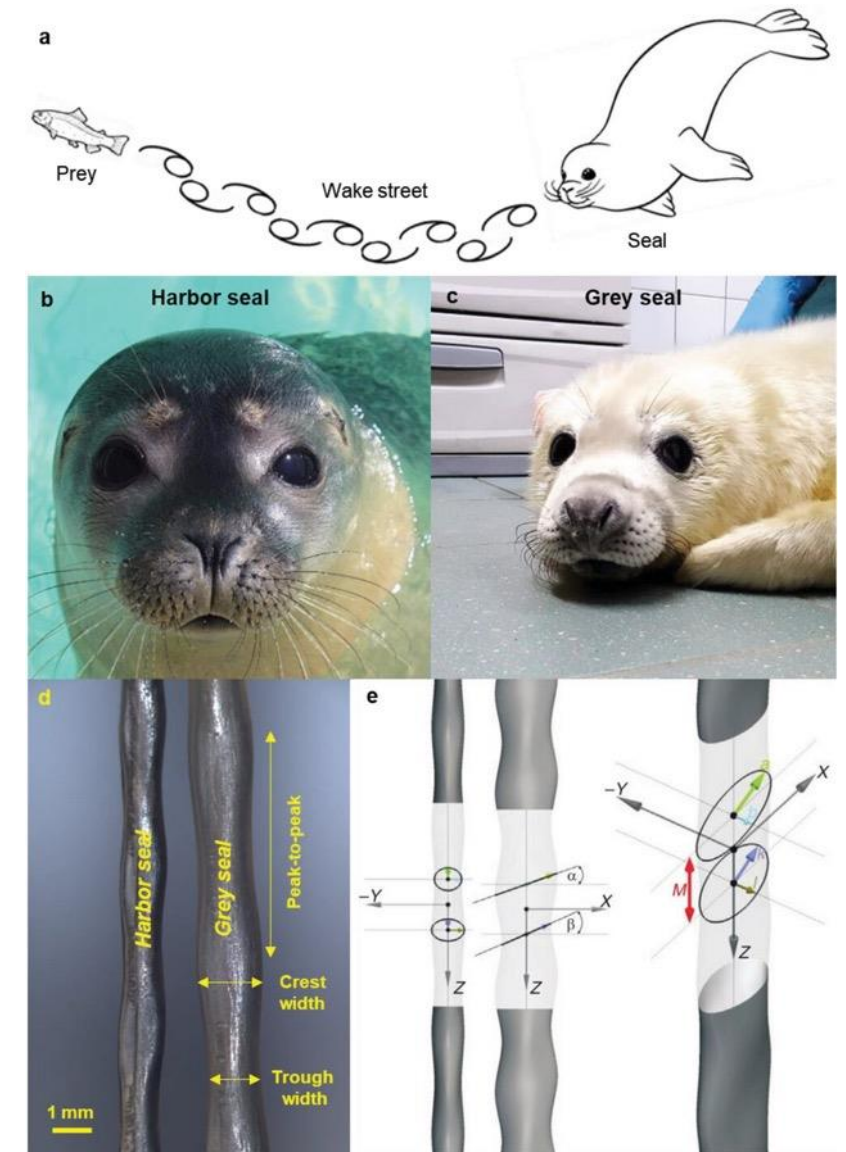

Hydrodynamic perception of harbor seals and grey seals with their whiskers

6. Animals at risk and their specificities

c. Detection capabilities – Sirenians

- Sirenian vision is better suited for focusing on objects further than 1-m away than detection of close-by objects (Bauer et al., 2003; A. M. Moore et al., 2022).
- West Indian manatees have dichromatic vision, inhibiting their ability to distinguish colors from grey; they can, however, discriminate between brightness levels (Griebel & Schmid, 1997).
- Manatees have whole-body distribution of vibrissae, which they use for both tactile investigation and detection of hydrodynamic stimuli (Reep et al., 1998).
- Along with vibrissae, manatees possess stiff whiskers around their mouths, allowing for tactile sensation and detection of changes in water current and pressure (Florida Fish And Wildlife Conservation Commission, n.d.).



Manatee vibrissae and whiskers

- Sirenian hearing was experimentally determined to be within the range of 0 to 90.5 kHz, with greatest sensitivity at 16 – 18 kHz (Gaspard et al., 2012; Moore et al., 2022).

6. Animals at risk and their specificities

c. Detection capabilities – Sea turtles

- While sea turtles are somewhat nearsighted on land, they spend most of their time in well-lit surface waters and have well developed visual systems (Lutz et al., 2002).
- The optical system of sea turtles enables the detection of UV light, along with spectral sensitivity ranging from ≈ 400 to 640 nm (Swimmer & Brill, 2006).
- Leatherback sea turtles have peak visual sensitivity to blue/green wavelengths (around 500 nm) of light and green turtles to orange light (around 600 nm) (Swimmer & Brill, 2006).
- Sea turtles' photoreceptors contain different colored oil droplets that allow them to broaden their range of color perception and increase their color discrimination (Southwood et al., 2008).
- Sea turtles hear low-frequency sounds within the range of 100 to 1000 Hz, with greatest sensitivity between 200 and 400 Hz (Moein Bartol & Musick, 2003).

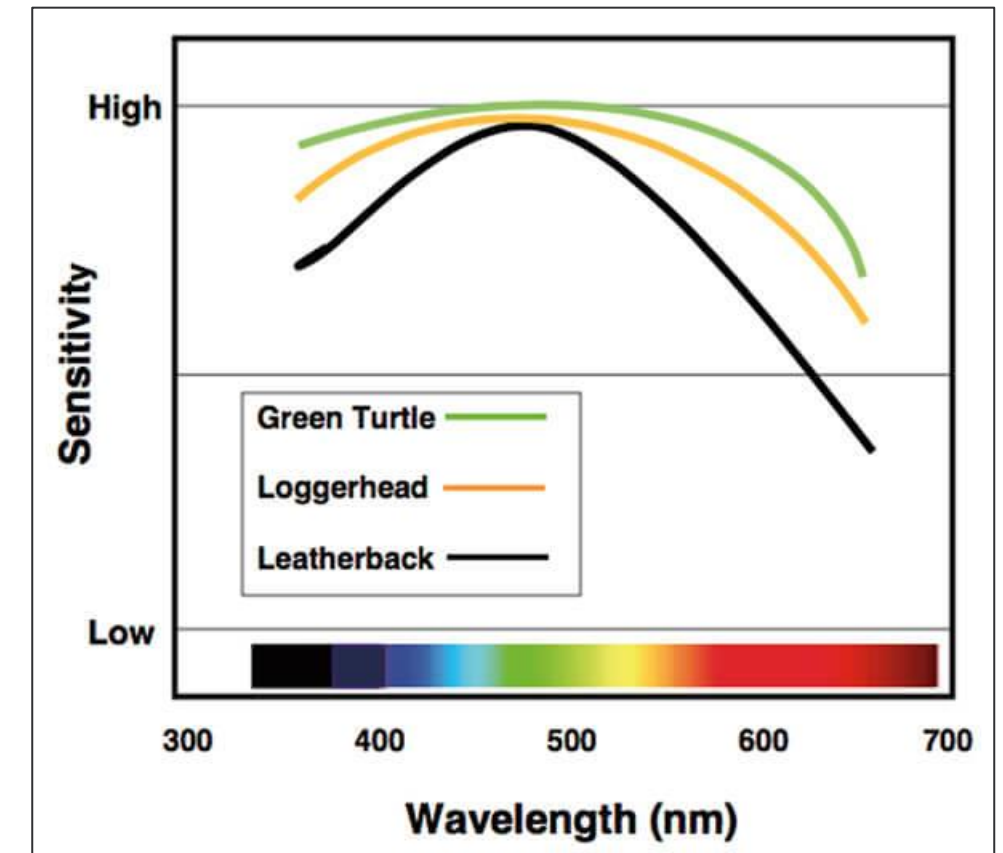

Sea turtle sensitivity to the spectrum of light wavelengths

- Green sea turtles, for example, detect a frequency range of 200-700 Hz with highest sensitivity around 400 Hz (Ridgway et al., 1969).

6. Animals at risk and their specificities

c. Detection capabilities – Elasmobranchs

- Elasmobranchs can detect objects through multiple senses: hearing, olfaction (i.e., smell), vision, pressure and vibrations, electro-perception, taste, and touch.
- Many pelagic shark species are attracted to low-frequency sounds in the 25 to 1000 Hz, with attractiveness increasing as frequency decreases (Myrberg et al. 1976; Myrberg 2001).
- Irregularly pulsed sounds, such as movement of prey, are more attractive to sharks than regularly pulsed sounds (Myrberg et al. 1976), such as noises emitted from submerged permanent or semi-permanent objects.
- The sense of smell is highly developed in sharks, allowing them to sense prey, communicate, and navigate from over 100 m away from a source (Collin et al. 2015).

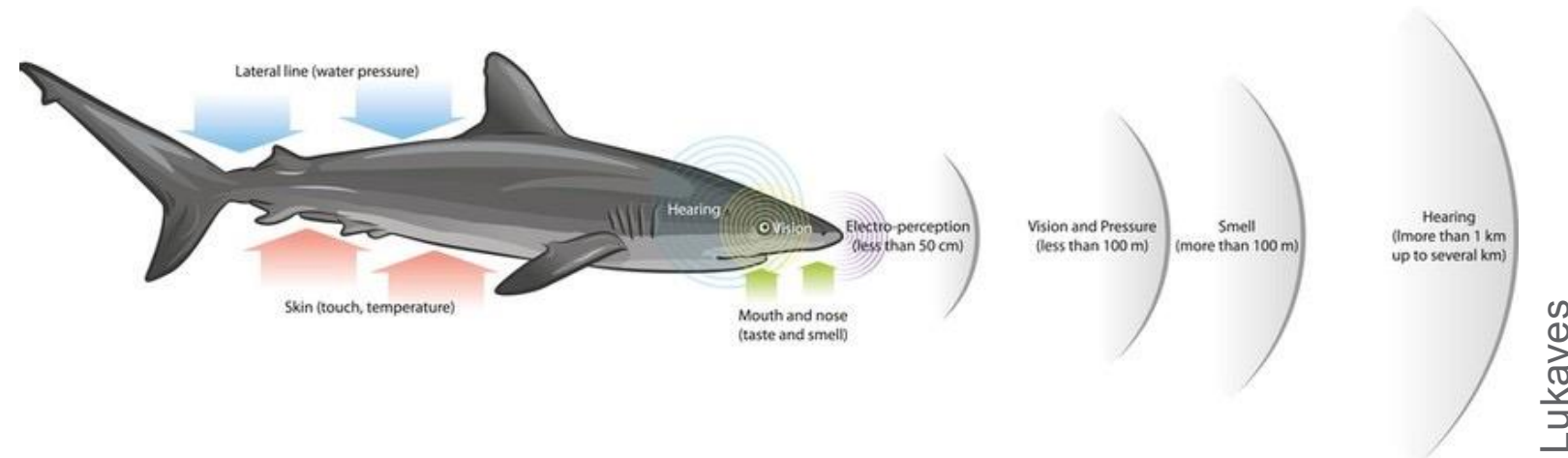

6. Animals at risk and their specificities

c. Detection capabilities – Elasmobranchs

- Increased eye size in pelagic elasmobranchs is likely an adaptation for improved sensitivity and visual acuity (Land & Nilsson, 2012).
- Oceanic sharks exhibit relatively high spatial resolution and improved visual acuity, compared to benthic shark species that tend to have smaller eyes and may rely on other non-visual senses (Lisney & Collin, 2007; Raschi et al., 2001).
- Elasmobranchs that spend more time at depth tend to have visual pigments shifted toward shorter wavelengths (470-485 nm, blue shifted), while those spending more time in surface waters have visual pigments shifted towards longer wavelengths (500-510nm) (Hart et al., 2011).
- Elasmobranchs have the ability to detect electric field signals from their prey (Kim 2007); however, it remains uncertain whether species can distinguish between natural and anthropogenic EMF signals (Collin et al. 2015; Newton et al. 2019).



6. Animals at risk and their specificities

c. Detection capabilities – Large fish

- Ocean sunfish have been found to have visual acuity similar to adult sharks, but lower than other large pelagic fish, like the blue marlin, with visual acuity increasing with body size (Fritsches et al., 2003).
- Ocean sunfish have the highest visual clarity at the lower frontal portion of their visual field; this is advantageous for detecting prey, moving through the water column, and foraging on the seafloor (Kino et al., 2009).
- Billfishes have large eyes, peak sensitivity around 484 nm (blue-green) and may have potential for color vision (Collin et al., 2000).
- Other large pelagic fish, including tunas and swordfish, have peak sensitivity at 488 nm, and have likely adapted their vision for deeper, blue ocean water (Fritsches & Warrant, 2004).
- Pelagic species that hunt closer to the surface of the water have greater potential for color discrimination (Southwood et al., 2008).
- Tunas are hearing generalists, detecting low-frequency sounds less than 1000 Hz, with highest sensitivities around 200 to 500 Hz depending on species (Southwood et al., 2008).

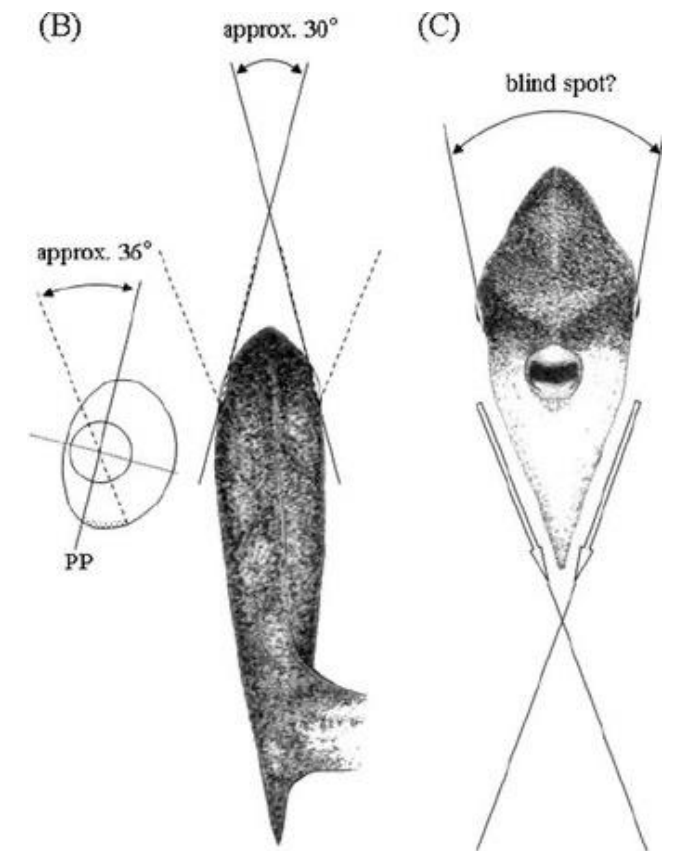

Visual field of ocean sunfish

Kino et al. 2009

7. Entanglement risk to marine megafauna

- Entanglement records from other industries, such as fishing, boating, and environmental monitoring have involved large whales, dolphins, sea turtles, and pinnipeds (Benjamins et al., 2014; Daniel et al., 2023; Dodge et al., 2022).
- Large fish, such as ocean sunfish, sharks like basking sharks, and rays have been caught in commercial fishing gear and may be at risk of entanglement in ropes and lines (Benjamins et al., 2014).
- Records of sirenian (manatees) entanglement are rare but have been documented in crab pot lines and other ropes (Beck & Barros, 1991).
- Entanglement in anthropogenic materials can lead to asphyxiation, tissue damage, difficulty with movement or foraging, increased drag if towing entangled material, and potential population level effects on vulnerable species if an entangled animal dies or is unable to reproduce or care of its young (Benjamins et al., 2014; Cassoff et al., 2011; Moore & van der Hoop, 2012).



NOAA Fisheries



Oceana USA

7. Entanglement risk to marine megafauna

a. Animal behavior near mooring lines

- Animal behavior near mooring lines and power cables can be informed by observations from other marine industries and activities.
- In 2013, green sea turtles were observed foraging on an algae encrusted mooring line used to secure a vessel (de Carvalho-Souza et al., 2016).
- The turtles took strong bites, exposing the nylon rope filaments, and were observed taking breaks to rest after feeding, remaining motionless in the water column before swimming away.
- Sustained grazing can lead to weakened mooring lines, ingestion of nylon fibers, and increased presence near the mooring system due to increased feeding opportunities (de Carvalho-Souza et al., 2016).

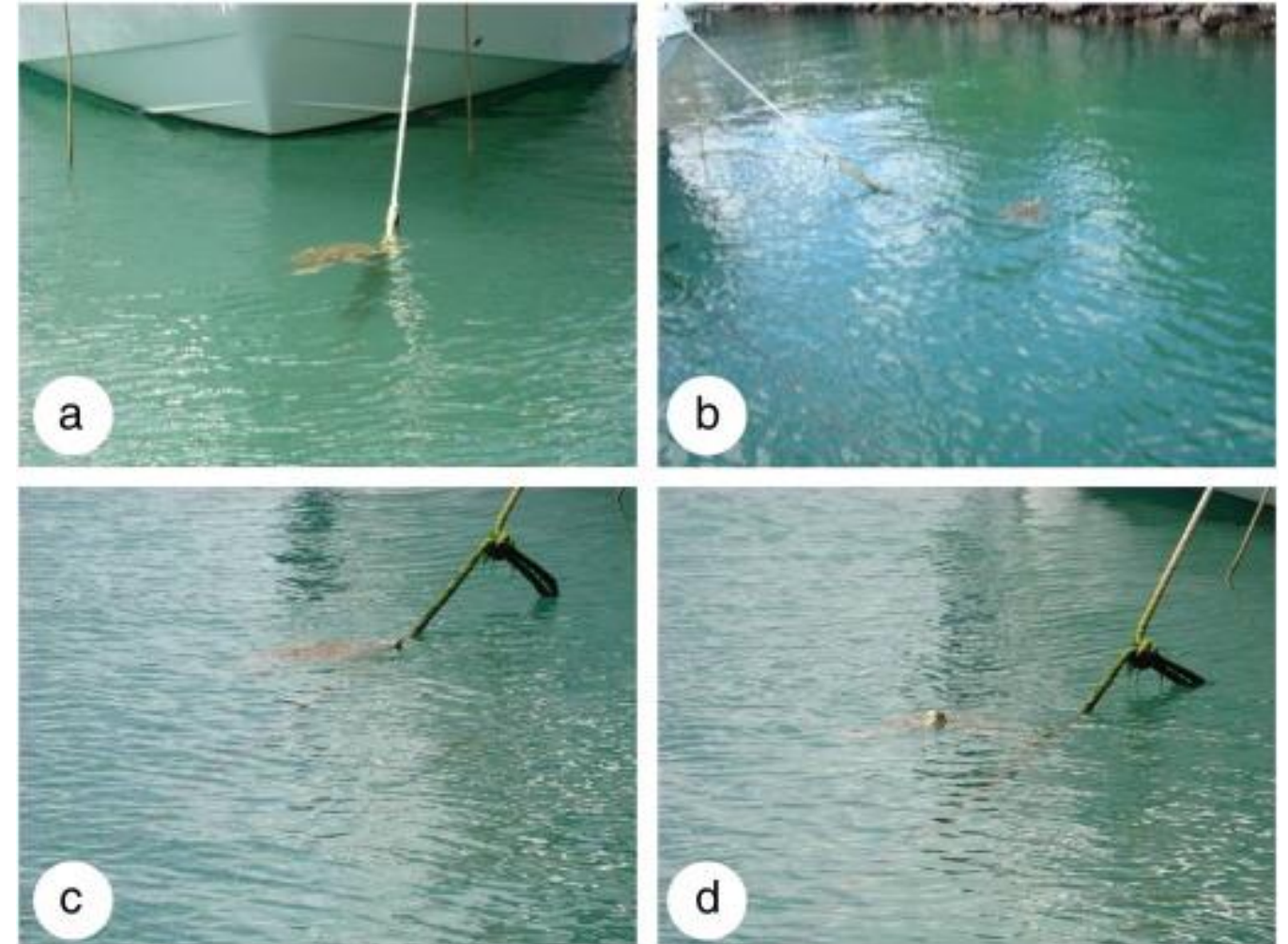

Green turtle feeding behavior at algae-encrusted mooring ropes

7. Entanglement risk to marine megafauna

b. Entanglement observations

- No entanglement of animals has been observed in the mooring lines or cables of marine energy devices, and a single event has been reported so far of a leatherback turtle entanglement in the surface line of an oceanographic instrument.
- Most documentation of megafauna entanglement comes from encounters with fishing gear.
- Between 1980 and 2009, 1032 events of north Atlantic right whale entanglements in fishing gear were documented, involving at least 626 different whales (Knowlton et al. 2012).
- At least 306 of these whales got entangled more than once, one of them having been found entangled at least seven times, and five whales at least six times.
- While entanglement rates were similar for males and females, juveniles presented a higher entanglement rate.



7. Entanglement risk to marine megafauna

b. Entanglement observations

- In Florida, about 6% of the strandings of dolphins, manatees, and sea turtles recorded between 1997 and 2009 were identified as resulting from entanglement with fishing gear, increasing throughout the time period: 132 dolphins, 380 manatees, and 1070 sea turtles (Adimey et al., 2014).
- Entangling fishing gear were monofilament lines (75%), trap pot gear (18%), nets (5%), and mixed gear (2%).



FFWCC



Brookfield Zoo

7. Entanglement risk to marine megafauna

b. Entanglement observations

- Data from the Disentanglement Network on the continental shelf of Massachusetts from 2005 to 2019 was used to analyze sea turtle entanglements (Dodge et al., 2022).
- 280 sea turtle entanglement events were recorded over that time, including 272 leatherback turtles.
- Of the 272 leatherback entanglements, 251 occurred from buoy lines, of which 92% were from fishing pots or traps, 3% were from boat mooring lines, and the other 5% were from other buoy lines like those used in aquaculture or with research pots and traps.
- In the majority of cases, the line was wrapped around the neck or front flippers of the turtle, and almost all were entangled near the surface, within two body lengths of the buoy (Dodge et al., 2022).
- For most of these sea turtle entanglements, the buoy line was white (68%), of 0.95-cm diameter (94%), and made of polyblend material (86%).

Sea turtle entanglements in fishing gear near Cape Cod in 2005-2019

Gear characteristic	Entanglements	Percentage (%)
Buoy line color		
White	110	68
Green	23	14
Woven ^a	17	11
Blue	7	4
Black	2	1
Orange	2	1
Estimated buoy line diameter		
0.64 cm (1/4")	8	5
0.79 cm (5/16")	2	1
0.95 cm (3/8")	151	94
Estimated buoy line material		
Polyblend	138	86
Nylon	17	11
Cotton	4	2
Poly spliced to other	2	1
Buoy type		
Bullet with stick	90	41
Bullet	69	31
Acorn with stick	24	11
Stacked ^b	19	8.5
Acorn	6	3
Hardshell low drag	5	2
Surface system	5	2
Hardshell ball	2	1
Polyform	1	0.5
Buoy nose color		
White	62	31
Black	13	7
Other ^c	122	62

^aA 50/50 mix of strand colors. For all others, the dominant color was chosen and colored tracers were ignored

^bMultiple buoys of any type on the same stick

^cAny color that is not black or white, including multi-colored

7. Entanglement risk to marine megafauna

c. Entanglement process

- A sea turtle entanglement event in fishing and mooring lines was simulated using footage from disentanglement and rescue events, and one witnessed event, in order to understand how entanglement occurs (MacNicoll et al., 2017).
- In the simulation, the entanglement began with a turtle encountering a mooring line and making contact, followed by the line wrapping around the turtle's flipper or shoulder (or neck in severe cases).
- Sensing the entanglement, the turtle would attempt to turn and disentangle itself; however, with the unintended effect of tightening the loop.
- A second simulation was completed with a mooring line with higher stiffness, leading to the line not wrapping around the turtle's limbs and the turtle not becoming entangled (MacNicoll et al., 2017).

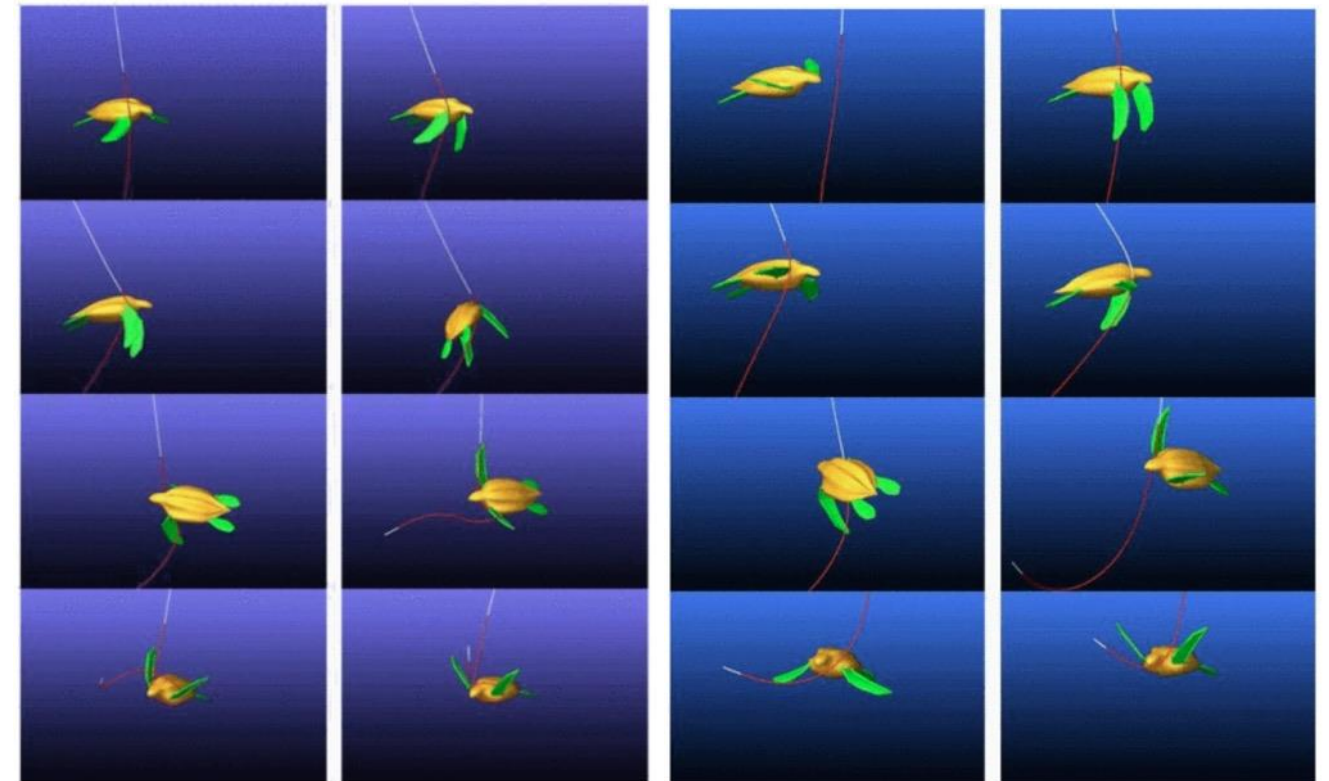

Turtle simulation of entanglement with mooring line (left) and simulation of same event but with higher mooring stiffness, resulting in an encounter, but no entanglement (right)

7. Entanglement risk to marine megafauna

c. Entanglement process

- Another group of researchers developed an interactive tool to simulate the entanglement of a north Atlantic right whale in the ropes of fishing pots, enabling whale behavior such as swimming motion, body roll, vertical and horizontal direction shifts, and surface activities (Howle et al., 2018).
- A flipper and body entanglement was obtained with the whale engaging in a body roll upon initial contact with the rope; flipper sweep angle and body roll direction were important factors influencing whether an entanglement was happening, and its severity.
- Peduncle entanglements were the results of different behaviors, such as an evasion turn upon encounter that resulted in wrapping the tail, contact with the rope followed by surface activity, or a flipper and body wrap that slips along the body, freeing the flipper but entangling the peduncle (Howle et al., 2018).

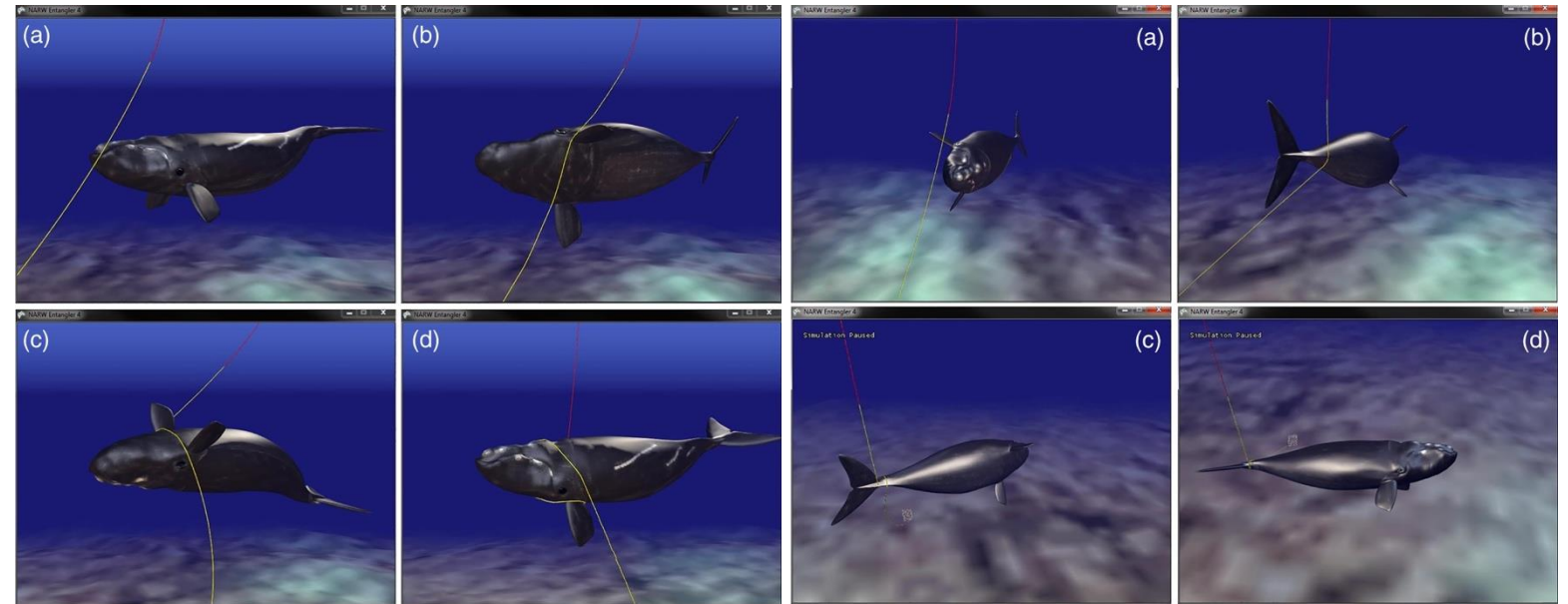

Simulations of a north Atlantic right whale entanglement in a fishing line, resulting in a flipper and body wrap (left) or in a peduncle wrap (right)

7. Entanglement risk to marine megafauna

d. Entanglement risk

Risk based on animals' biological characteristics

- Entanglement risk of marine megafauna from mooring systems can be estimated based on physical characteristics of the animals, such as body size, body flexibility, ability to accurately detect mooring components, and foraging styles (Benjamins et al., 2014).

Entanglement risk for megafauna groups based on four biological risk parameters. Each parameter was scored on a scale of two or three (1 = lower relative risk, 2/3 = higher relative risk). The total entanglement risk scored from four (minimal risk) to ten (maximum risk) (Benjamins et al. 2014)

Species group			Entanglement risk based on total body length (TL) TL <5m = 1 TL = 5-10m = 2 TL >10m = 3	Entanglement risk based on body flexibility: Relatively flexible = 1 Relatively rigid = 2	Ability to accurately detect object at distances of: >10 body lengths = 1 1-10 body lengths = 2	Entanglement risk based on foraging style Pursuit hunters = 1 Filter feeders = 2 Lunge feeders = 3	TOTAL (A+B+C+D; min. = 4, max. = 10)
Cetaceans	Baleen whales	Large whales	3	2	2	2, 3	9, 10
		Medium-sized whales	2	2	2	3	9
	Toothed whales	Sperm whale	3	2	1	1	7
		Medium-sized whales and dolphins	2	2	1	1	6
		Small whales, dolphins and porpoises	1	2	1	1	5
Pinnipeds	Seals	1	1	2	1	5	
	Sea lions, fur seals etc.	1	1	2	1	5	
Sea turtles		1	2	2	1	6	
Sharks	Basking sharks	2	1	2	2	7	
	Other large sharks	1	1	2	1	5	
Ocean sunfish		1	2	2	1	6	

7. Entanglement risk to marine megafauna

d. Entanglement risk

- Relative to body length, cetaceans, particularly large baleen and sperm whales have the highest entanglement risk, while smaller animals, such as small and medium sized whales and dolphins, ocean sunfish, seals, and sea turtles have lower entanglement risks.
- In relation to body flexibility and the ability to easily maneuver around lines to avoid entanglement, cetaceans, sea turtles, and sunfish are at the highest risk, while more flexible species such as pinnipeds and sharks are at relatively lower risk.
- In terms of their ability to detect the mooring lines, almost all megafauna groups were assessed as having detection distances from 1-10 body lengths; only the toothed whales (e.g., sperm whale, dolphins, porpoises, etc.) had a detection distance of greater than 10 body lengths because of their ability to echolocate (Benjamins et al., 2014).
- Animals that rely more on sight, such as sea turtles, would likely need to approach the lines closer for detection, than those that rely on echolocation.
- Relative to their foraging styles, animals that lunge feed, such as some baleen whales like humpbacks, have a higher risk of entanglement near mooring lines.
- Filter feeders (e.g., some baleen whales like gray whales, basking and whale sharks) have the next highest relative entanglement risk, and pursuit hunters (e.g., toothed whales, pinnipeds, other large sharks, sunfish) have the lowest relative risk (Benjamins et al., 2014).

7. Entanglement risk to marine megafauna

d. Entanglement risk

- Tallying the risk scores from these biological characteristics, small-sized toothed whales (e.g., porpoises, dolphins), pinnipeds, and large sharks other than basking sharks appear to be at least risk of entanglement based on the overall biological risk score (5).
- Medium and large-sized toothed whales, sea turtles, basking sharks, and ocean sunfish are at greater relative risk (6-7), and medium and large baleen whales have the greatest overall entanglement risk (9-10) (Benjamins et al., 2014).

Species group			TOTAL (A+B+C+D; min. = 4, max. = 10)
Cetaceans	Baleen whales	Large whales	9, 10
		Medium-sized whales	9
	Toothed whales	Sperm whale	7
		Medium-sized whales and dolphins	6
		Small whales, dolphins and porpoises	5
Pinnipeds	Seals	5	
	Sea lions, fur seals etc.	5	
Sea turtles		6	
Sharks	Basking sharks	7	
	Other large sharks	5	
Ocean sunfish		6	

7. Entanglement risk to marine megafauna

d. Entanglement risk

Risk based on mooring types

- Combining risk assessments based on animal characteristics and the physical characteristics of marine energy mooring system configurations (i.e., tension, swept volume, curvature), the taut configuration presented the lowest relative risk for all megafauna groups (Benjamins et al., 2014).

Relative entanglement risk assessment for megafauna groups and marine energy mooring type based on physical and biological risk assessments. Relative risk increases as the color of the cell increases. LF = lunge feeder, FF = filter feeder, footnote 2 marks species not occurring in Scottish waters (Benjamins et al. 2014)

Species group		Catenary & chain	Catenary & chain & nylon	Catenary & chain & polyester	Taut & nylon	Catenary & accessory buoy	Taut & accessory buoy
Cetaceans	Baleen whales	Large whales (LF)	Dark Blue	Dark Blue	Dark Blue	Light Blue	Dark Blue
		Large whales (FF)	Dark Blue	Dark Blue	Dark Blue	Light Blue	Dark Blue
		Medium-sized whales (LF)	Dark Blue	Dark Blue	Dark Blue	Light Blue	Dark Blue
	Toothed whales	Sperm whale	Light Blue	Light Blue	Light Blue	Light Blue	Light Blue
		Medium-sized whales and dolphins	Light Blue	Light Blue	Light Blue	Light Blue	Light Blue
		Small whales, dolphins and porpoises	Light Blue	Light Blue	Light Blue	Light Blue	Light Blue
Pinnipeds	Seals	Light Blue	Light Blue	Light Blue	Light Blue	Light Blue	
	Sea lions, fur seals etc. ²	Light Blue	Light Blue	Light Blue	Light Blue	Light Blue	
Sea turtles		Light Blue	Light Blue	Light Blue	Light Blue	Light Blue	
Sharks	Basking sharks	Light Blue	Light Blue	Light Blue	Light Blue	Light Blue	
	Other large sharks	Light Blue	Light Blue	Light Blue	Light Blue	Light Blue	
Ocean sunfish		Light Blue	Light Blue	Light Blue	Light Blue	Light Blue	

7. Entanglement risk to marine megafauna

d. Entanglement risk

- Baleen whales are at higher relative risk for all other mooring configuration types.
- Toothed whales (except small whales, dolphins and porpoises), sea turtles, basking sharks, and the ocean sunfish are at moderate relative risk for all other configuration types.
- The lowest relative entanglement risk is faced by small toothed whales, dolphins, and porpoises, pinnipeds, and large sharks (except basking/whale sharks) around catenary and chain (and polyester) moorings, taut moorings, and taut moorings with accessory buoys.
- Catenary mooring configurations that include chain and nylon or accessory buoys have lower tension than other configurations and may pose a relative greater risk to these animals (Benjamins et al., 2014).

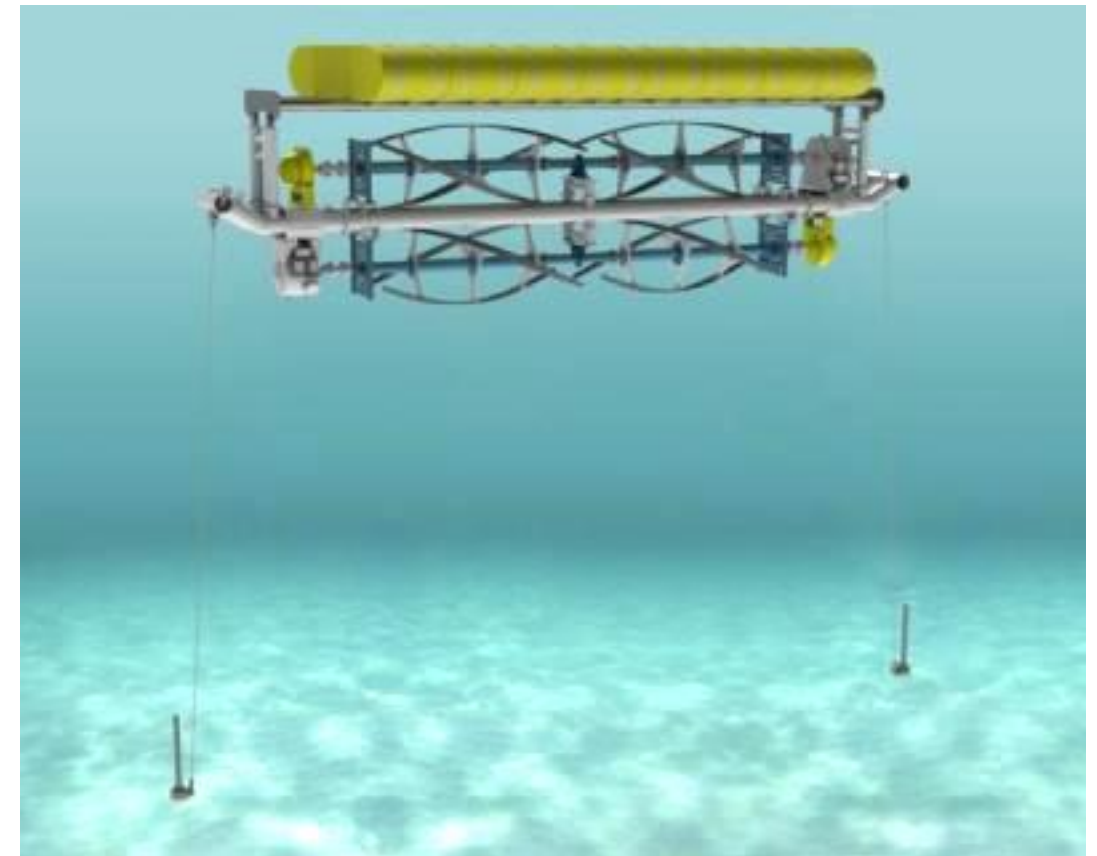

7. Entanglement risk to marine megafauna

d. Entanglement risk

- The single vertical mooring lines of oceanographic instruments are unlikely to entangle marine organisms.
- However, subsurface moorings may present some entanglement risk to animals in the water column, depending on the depth of the top of the deployment and the depth to which specific animals dive and swim.
- The animals most likely to be at risk are large whales and perhaps some sea turtles, as other species have greater maneuverability, should they encounter a line.
- On the other hand, the surface lines sometimes associated with oceanographic instruments are likely to pose the most significant risk of entanglement.
- Animals swimming at the surface, in particular sea turtles, may swim between the two surface floats without detecting the floating line and become entangled as, in these case, the floats do not provide enough resistance to keep the surface line taut.



8. Entanglement mitigation strategies

- Marine energy mooring systems do not have any loose end and are already relatively taut, making entanglement risk very unlikely.
- Nevertheless, several mitigation strategies can be employed to make the chains, ropes, and/or lines more detectable by animals.
- Regarding oceanographic instruments, the highest risk for marine animal entanglement is likely to be floating surface lines that are often flexible and offer little resistance to animal interactions.
- Removing these surface lines would lower the risk, at the cost of greater retrieval convenience of the oceanographic instruments.
- Other placements of oceanographic instruments (seabed mounted, subsurface) present lower risks of entanglement but may still benefit from some mitigation depending on the material and stiffness of the mooring lines.
- Several strategies exist from the fishing industry to make gear more detectable by animals or to weaken lines at strategic places to release caught animals, that may be applicable to oceanographic deployments.

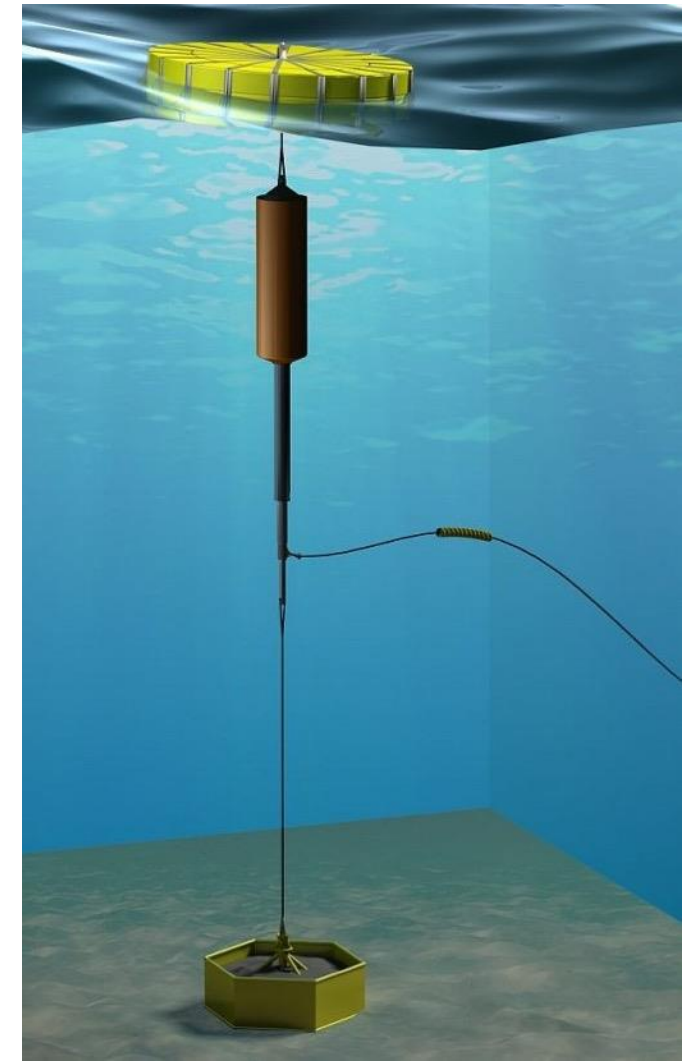

8. Entanglement mitigation strategies

a. Strategies to increase mooring detectability

- Increasing detectability of the mooring lines and cables by the animals is primordial.
- Fishing and aquaculture industries have long used acoustic deterrent devices, or pingers, to reduce marine mammal bycatch and depredation, with inconclusive results (Hamilton & Baker, 2019).
- Results are very much species- and location specific, with signs of habituation, and even attraction, to pingers observed in some cetacean and pinniped species.
- In addition, the acoustic emissions from pingers may reach harassment levels set forth in the NMFS Technical Guidance on anthropogenic sounds and marine mammals (National Marine Fisheries Service, 2024) and lead to animal displacement from crucial habitats (Hemery et al., 2024).
- The chain components of a mooring system, if able to clank, may generate sufficient noise to deter some species, though also attract the curious ones.
- For these reasons, increasing the acoustic footprint of the mooring system, through pingers or other methods, is unlikely to provide reliable mitigation strategies to increase detectability and reduce entanglement risk.



8. Entanglement mitigation strategies

a. Strategies to increase detectability

- Increasing visibility of the mooring system components may be a more reliable strategy, by either using thicker lines, ropes, or chains, or using colors that animals at risk can detect.
- Various studies have suggested that large whales (e.g., minke, humpback, right) may better detect rope colors that contrast with the natural blue-green background in the photic zone during daylight periods, such as orange or white (Kot et al. 2012), with right whales detecting red and orange ropes from a greater distance than the black or green ones (Kraus et al., 2014).
- Sea turtles, on the other hand, have peak sensitivity to colors such as blue and green (leatherback turtle) and yellow and orange (loggerhead and green sea turtle) (Levenson et al., 2004; Swimmer & Brill, 2006).
- If whales and sea turtles are both taxa of concern in a deployment area, a solution may be to use synthetic ropes with different colors of strands or patterns, like a mix of white, orange, and green.



8. Entanglement mitigation strategies

a. Strategies to increase detectability

- Efforts from fisheries bycatch reduction research have shown the addition of UV or green light emitting diodes (LEDs) can result in a significant reduction in sea turtle or seabird entanglement with lines and nets (Mangel et al., 2018; Wang et al., 2013).
- However, it is cautioned that light emissions may affect species differently, for example attracting pinnipeds and fish, and this should be considered carefully if used as an entanglement mitigation strategy.
- Additional avenues to increase detectability involve increasing the acoustic reflectivity of the mooring systems to be better detected by echolocating marine mammals, or increase the water turbulence generated around the mooring line to increase detectability by animals with whiskers or lateral lines.
- However, these approaches would require more research on their effectiveness.



8. Entanglement mitigation strategies

b. Strategies that involve mooring system integrity

- Animal entanglement simulation studies found that when line tension and bending stiffness were increased for pot ropes and mooring lines, the risk of entanglement for large whales and sea turtles decreased, as it enabled the animals to interact with the line without getting it looped around a body part (Howle et al., 2018; MacNicoll et al., 2017).
- Whenever possible, stiffer and less bendy wire or synthetic ropes should be prioritized, by selecting lines with larger diameters and/or made of stiffer material.
- Conversely, another study argued that ropes with relatively low breaking strength (i.e., < 7.56 kilonewtons) would enable large whales to break free from a life-threatening entanglement (Knowlton et al., 2016).
- However, this study was focused on fishing ropes; while this rope strength is orders of magnitudes lower than what marine energy mooring systems require, it may be sufficient for short-term deployments of oceanographic instruments to withstand routine operation, especially if the use of a surface line is required.



Triton Systems

8. Entanglement mitigation strategies

b. Strategies that involve mooring system integrity

- An alternative to using entire mooring lines of lower strength for oceanographic instruments is to embed within strategic sections of the lines a weak link insert or splice in a length of weaker-strength rope, like those used in the northeast trap/pot fishery (NOAA Fisheries, 2022).
- These approved links and splice mitigation strategies have a 1,700-pound breaking strength and would break free if a whale becomes entangled.
- The breaking strength would be significantly lower for smaller animals like sea turtles (Dodge et al., 2022) and additional research may be required to develop weak link inserts or splices that will work with sea turtles and small pinnipeds.

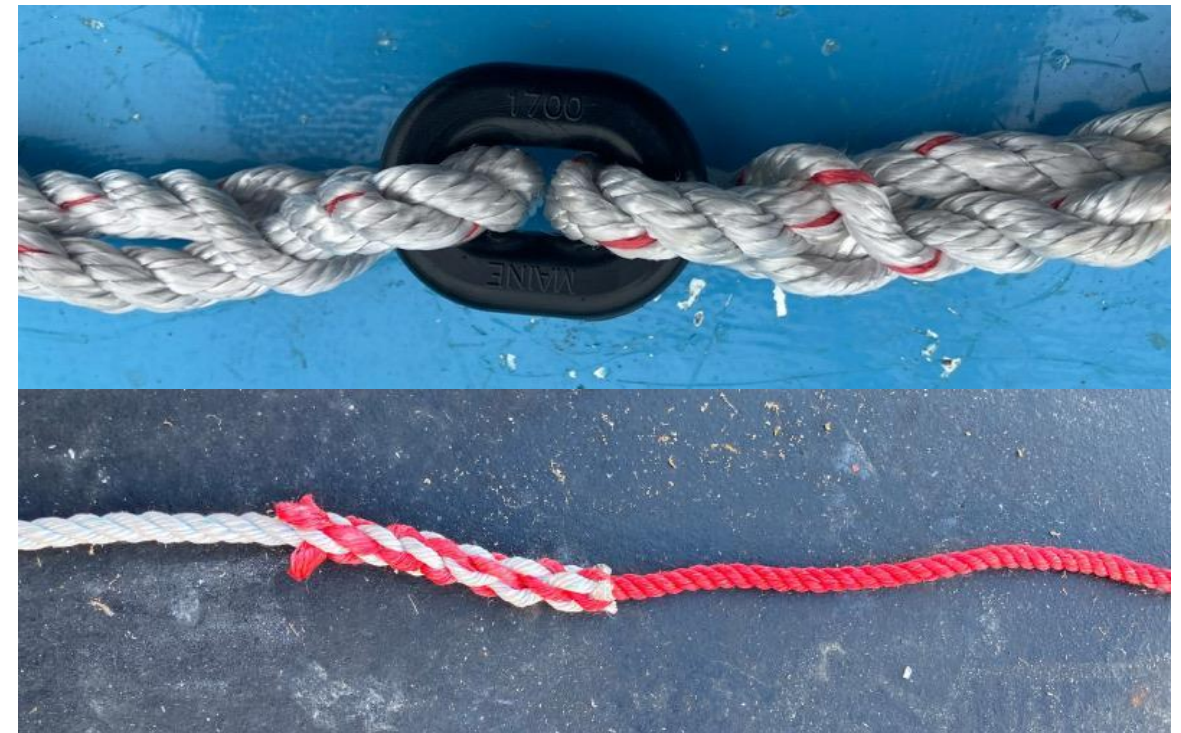

Examples of weak link insert (top) and splice (bottom)

8. Entanglement mitigation strategies

b. Strategies that involve mooring system integrity

- Finally, other entanglement mitigation strategies are more focused on monitoring integrity and maintaining proper functioning of the mooring systems (ORJIP, 2022).
- One crucial strategy includes performing routine visual inspections of the lines and cables to identify any potential weak points that would need repairs or any tangled derelict debris or fishing gear that would need removal.
- Another strategy includes installing tension sensors on the mooring lines, such as strain gauged load measuring pins, to monitor and maintain tension.
- Distributed Acoustic Sensing (DAS) or Fiber Bragg Grating (FBG) technologies can also be used to monitor mooring line integrity, by embedding fiber optic cables into the mooring lines, or attached along, to detect strain, fatigue, and structural failures (Lee et al. 2023).

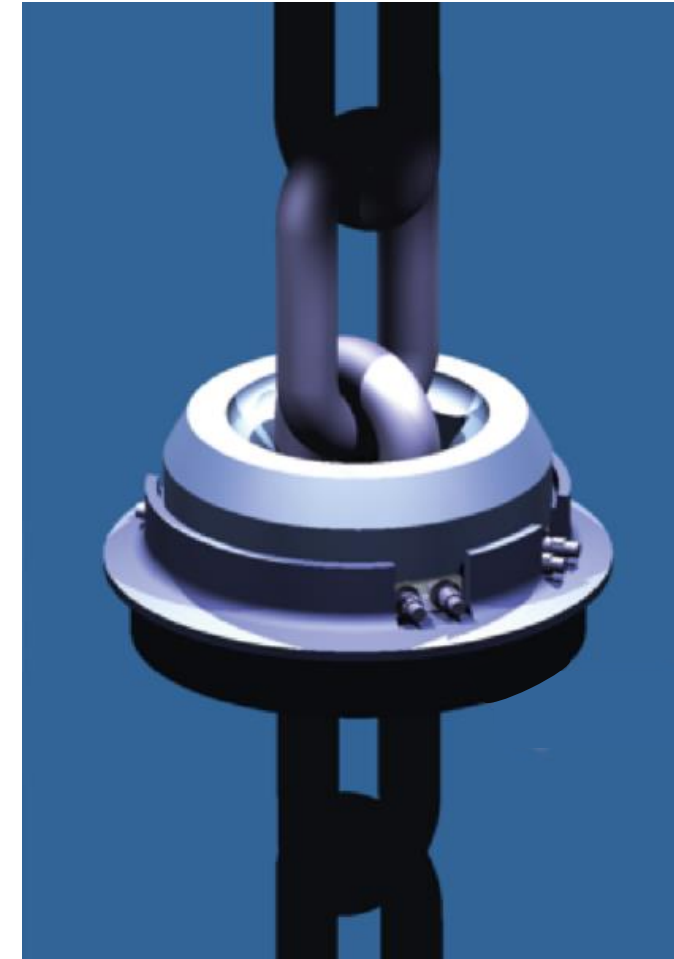

8. Entanglement mitigation strategies

c. Strategies to increase mooring reactivity

- When integrated into mooring systems, elastic hawsers can slowly stretch to double their resting length, then return to the original length.
- This adds variable length to a mooring line while remaining under constant tension, in both horizontal and vertical wave motion.
- Elastic hawsers can help reduce scope (length of mooring line), loads on connection points, and the watch circle of a device or buoy.
- Initially designed for floating docks, elastic hawsers can be integrated in a taut mooring configuration for marine energy devices and oceanographic instruments.
- Tension buoys are self-adjusting tensioning systems that can manage changes in water-level range and could provide a surface solution for oceanographic instruments.

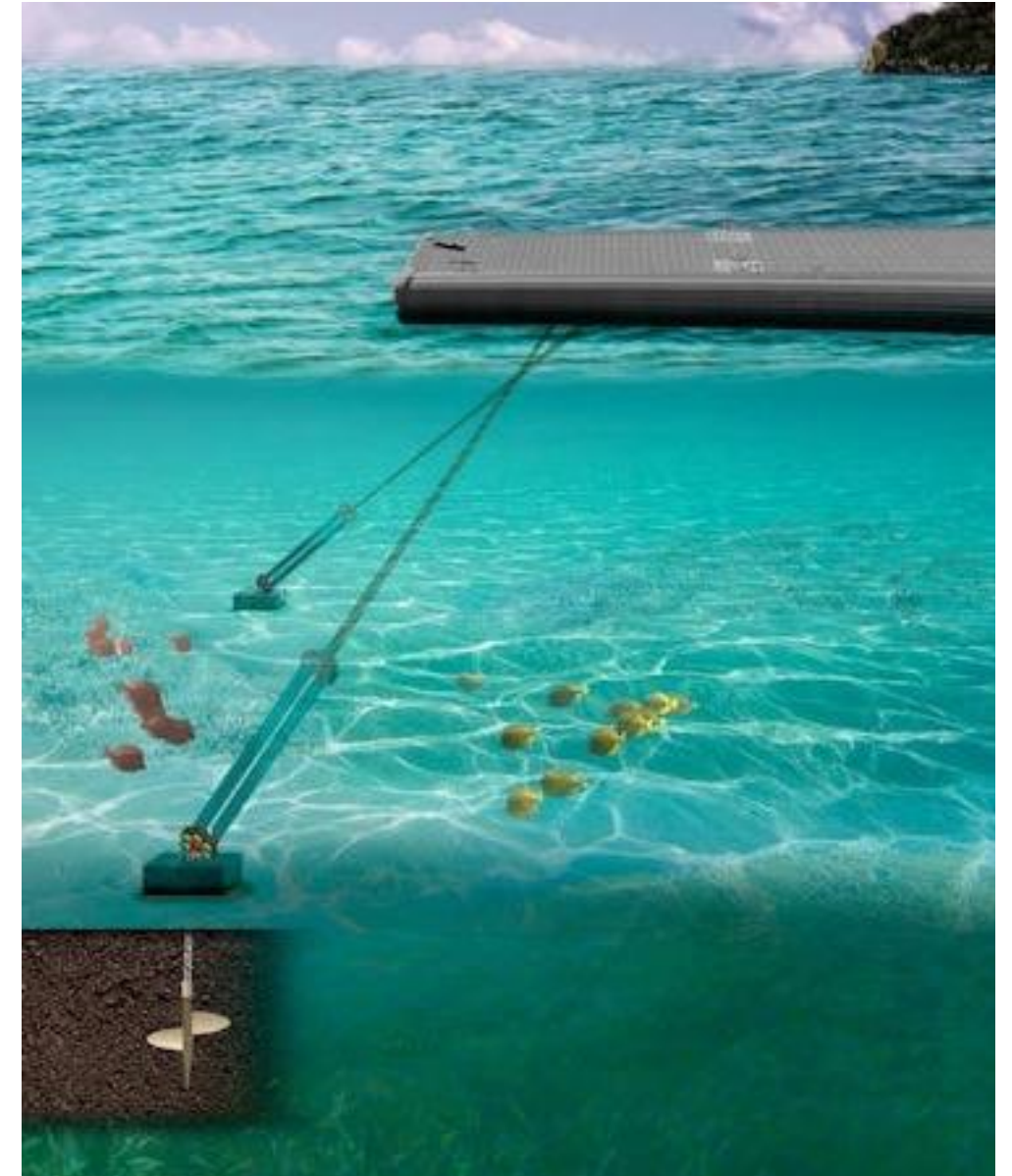

9. Conclusions

- Mooring systems used for floating marine energy devices and oceanographic instruments vary widely in configuration, material, and diameter, influencing their relative entanglement risks for marine megafauna.
- While remaining a low risk, catenary moorings and systems with accessory buoys present the highest entanglement risk due to increased curvature, movement, and swept volume.
- Taut mooring systems without accessory buoys consistently demonstrate the lowest entanglement risk because of their high tension and reduced flexibility.
- Large whales, especially baleen whales, present the greatest biological vulnerability based on their body size, lower maneuverability, feeding style, and limited detection capabilities at close range.
- Sea turtles, basking sharks, and ocean sunfish exhibit moderate risk, largely influenced by body rigidity, feeding behavior, and reliance on vision for detecting submerged lines.
- Pinnipeds, small odontocetes, and many large sharks show lower entanglement risk because of their higher maneuverability, better sensory capabilities, or both.

9. Conclusions

- To date, very few entanglement events have been linked to marine energy or oceanographic moorings, but extensive evidence from fisheries and boating demonstrates that entanglement in anthropogenic lines is a well-documented threat for marine animals.
- Oceanographic instrument deployments with floating surface retrieval lines carry notably higher risk, especially for sea turtles encountering slack or lightly tensioned lines near the surface.
- Mitigation strategies include improving line detectability (e.g., color selection, light cues), increasing line stiffness, using weak-link splices, or redesigning configurations to remove flexible surface lines.
- Applying a combination of engineering solutions, material choices, and placement strategies can significantly reduce interaction potential and help maintain low entanglement risk as marine energy and monitoring technologies continue to expand.

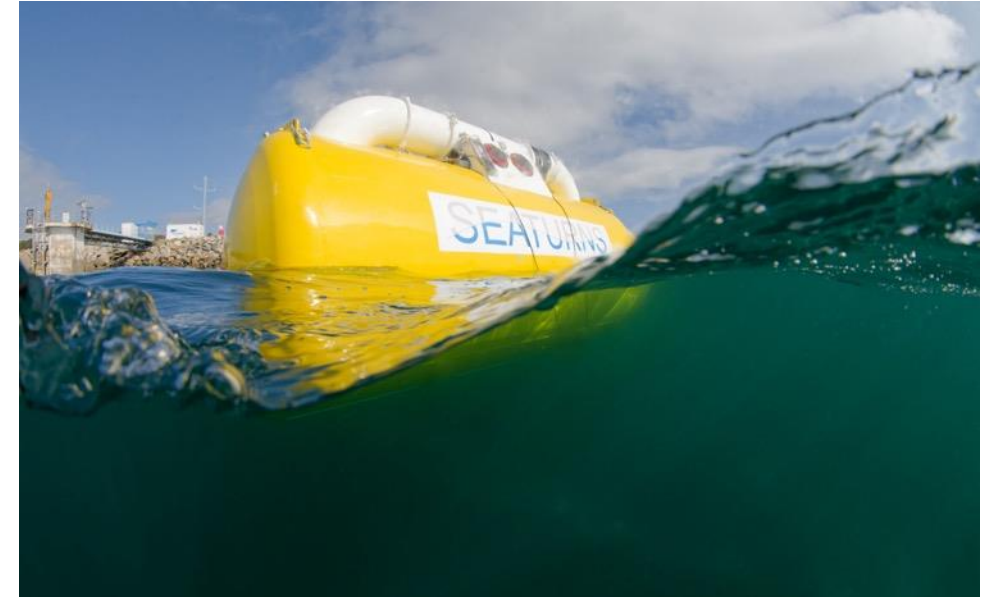

10. References

- Adimey, N.M., Hudak, C.A., Powell, J.R., Bassos-Hull, K., Foley, A., Farmer, N.A., White, L. & Minch, K., 2014. Fishery gear interactions from stranded bottlenose dolphins, Florida manatees and sea turtles in Florida, USA. *Marine Pollution Bulletin*, 81(1), 103–115. <https://doi.org/10.1016/j.marpolbul.2014.02.008>
- Ahmed Ali, M. O., Ja'e, I. A., & Zhen Hwa, M. G. (2020). Effects of water depth, mooring line diameter and hydrodynamic coefficients on the behaviour of deepwater FPSOs. *Ain Shams Engineering Journal*, 11(3), 727–739. <https://doi.org/10.1016/j.asej.2019.12.001>
- Bauer, G. B., Colbert, D. E., Gaspard III, J. C., Littlefield, B., & Fellner, W. (2003). Underwater visual acuity of Florida manatees (*Trichechus manatus latirostris*). *International Journal of Comparative Psychology*, 16(2). <https://doi.org/10.46867/C43P4V>
- Beck, C. A., & Barros, N. B. (1991). The impact of debris on the Florida manatee. *Marine Pollution Bulletin*, 22(10), 508–510. [https://doi.org/10.1016/0025-326X\(91\)90406-I](https://doi.org/10.1016/0025-326X(91)90406-I)
- Benjamins, S., Harnois, V., Smith, H., Johanning, L., Greenhill, L., Carter, C., & Wilson, B. (2014). Understanding the potential for marine megafauna entanglement risk from marine renewable energy developments (No. No. 791; p. 95). Scottish Natural Heritage.
- BOEM. (2024, August 20). The basking shark.. <https://www.boem.gov/newsroom/ocean-science-news/basking-shark>
- Cartamil, D. P., & Lowe, C. G. (2004). Diel movement patterns of ocean sunfish *Mola mola* off southern California. *Marine Ecology Progress Series*, 266, 245–253. <https://doi.org/10.3354/meps266245>
- Cassoff, R. M., Moore, K. M., McLellan, W. A., Barco, S. G., Rotstein, D. S., & Moore, M. J. (2011). Lethal entanglement in baleen whales. *Diseases of Aquatic Organisms*, 96(3), 175–185. <https://doi.org/10.3354/dao02385>
- Collin SP, Kempster RM, and Yopak KE. 2015. How elasmobranchs sense their environment. *fish physiology*. Academic Press.
- Collin, S. p., Marshall, N. j., Fritsches, K. A., Partridge, J. C., Pettigrew, J. D., & Marshall, N. J. (2000). Colour vision in billfish. *Philosophical Transactions of the Royal Society of London. Series B: Biological Sciences*, 355(1401), 1253–1256. <https://doi.org/10.1098/rstb.2000.0678>

10. References

- Coppola, L., Ntoumas, M., Bozzano, R., Bensi, M., Hartman, S. E., Charcos Llorens, M., Craig, J., Rolin, J.-F., Giovanetti, G., Cano, D., Karstensen, J., Cianca, A., Toma, D., Stasch, C., Pensieri, S., Cardin, V., Tengberg, A., Petihakis, G., & Cristini, L. (2016). Handbook of best practices for open ocean fixed observatories. [Report]. European Commission, Fix03 Project. <https://doi.org/10.25607/OBP-1488>
- Daniel, J. T., Costidis, A. M., & Barco, S. G. (2023). Fatal entanglements of sea turtles caused by widely deployed weather instruments. *Marine Pollution Bulletin*, 193, 115108. <https://doi.org/10.1016/j.marpolbul.2023.115108>
- Davenport, J., Munks, S. A., & Oxford, P. J. (1997). A comparison of the swimming of marine and freshwater turtles. *Proceedings of the Royal Society of London. Series B. Biological Sciences*, 220(1221), 447–475. <https://doi.org/10.1098/rspb.1984.0013>
- de Carvalho-Souza, G. F., de A. Miranda, D., & Pataro, L. (2016). Hazards in hanging gardens: A report on failures of recognition by green turtles and their conservation implications. *Marine Pollution Bulletin*, 105(1), 98–101. <https://doi.org/10.1016/j.marpolbul.2016.02.050>
- Dehnhardt, G., Mauck, B., & Bleckmann, H. (1998). Seal whiskers detect water movements. *Nature*, 394(6690), 235–236. <https://doi.org/10.1038/28303>
- Dodge, K. L., Landry, S., Lynch, B., Innis, C. J., Sampson, K., Sandilands, D., & Sharp, B. (2022). Disentanglement network data to characterize leatherback sea turtle *Dermochelys coriacea* bycatch in fixed-gear fisheries. *Endangered Species Research*, 47, 155–170. <https://doi.org/10.3354/esr01173>
- EMEC. (2016). Moorings and foundations catalogue, Deliverable 5.1 (p. 6). European Marine Energy Centre.
- Fish, F. (1997). Biological designs for enhanced maneuverability: analysis of marine mammal performance. In Tenth International Symposium on Unmanned Submersible Technology (pp. 109–117). Office of Naval Research.
- Fish, F. E. (2002). Balancing requirements for stability and maneuverability in cetaceans. *Integrative and Comparative Biology*, 42(1), 85–93. <https://doi.org/10.1093/icb/42.1.85>
- Florida Fish And Wildlife Conservation Commission. (n.d.). Florida manatee facts and information. Florida Fish And Wildlife Conservation Commission. <https://myfwc.com/education/wildlife/manatee/facts-and-information/>

10. References

- Fritsches, K. A., Marshall, N. J., & Warrant, E. J. (2003). Retinal specializations in the blue marlin: Eyes designed for sensitivity to low light levels. *Marine and Freshwater Research*, 54(4), 333–341. <https://doi.org/10.1071/mf02126>
- Fritsches, K., & Warrant, E. (2004). Do tuna and billfish see colors? *Pelagic Fisheries Research Program*, 9(1).
- Gaspard JC III, Bauer GB, Reep RL, et al. 2012. Audiogram and auditory critical ratios of two Florida manatees (*Trichechus manatus latirostris*). *Journal of Experimental Biology*, 215: 1442–1447.
- Griebel, U., & Peichl, L. (2003). Colour vision in aquatic mammals—Facts and open questions. *Aquatic Mammals*, 29(1), 18–30. <https://doi.org/10.1578/016754203101024040>
- Griebel, U., & Schmid, A. (1997). Brightness discrimination ability in the West Indian manatee (*Trichechus Manatus*). *Journal of Experimental Biology*, 200, 1587–1592.
- Hamilton, S., & Baker, G. B. (2019). Technical mitigation to reduce marine mammal bycatch and entanglement in commercial fishing gear: Lessons learnt and future directions. *Reviews in Fish Biology and Fisheries*, 29(2), 223–247. <https://doi.org/10.1007/s11160-019-09550-6>
- Hanke, W., Wieskotten, S., Marshall, C., & Dehnhardt, G. (2013). Hydrodynamic perception in true seals (Phocidae) and eared seals (Otariidae). *Journal of Comparative Physiology A*, 199(6), 421–440. <https://doi.org/10.1007/s00359-012-0778-2>
- Harnois, V., Smith, H. C. M., Benjamins, S., & Johanning, L. (2015). Assessment of entanglement risk to marine megafauna due to offshore renewable energy mooring systems. *International Journal of Marine Energy*, 11, 27–49. <https://doi.org/10.1016/j.ijome.2015.04.001>
- Hart, N. S., Theiss, S. M., Harahush, B. K., & Collin, S. P. (2011). Microspectrophotometric evidence for cone monochromacy in sharks. *Naturwissenschaften*, 98(3), 193–201. <https://doi.org/10.1007/s00114-010-0758-8>
- Hasan Maheen, M., & Yang, Y. (2023). Wave energy converters with rigid hull encapsulation: A review. *Sustainable Energy Technologies and Assessments*, 57, 103273. <https://doi.org/10.1016/j.seta.2023.103273>
- Hemery, L., Garavelli, L., Copping, A., Farr, H., Jones, K., Baker-Horne, N., Kregting, L., McGarry, L., Sparling, C., & Verling, E. (2024). Animal displacement from marine energy development: Mechanisms and consequences. *Science of the Total Environment*, 917, 170390. <https://doi.org/10.1016/j.scitotenv.224.170390>

10. References

- Howland, H. C. (1974). Optimal strategies for predator avoidance: The relative importance of speed and manoeuvrability. *Journal of Theoretical Biology*, 47(2), 333–350. [https://doi.org/10.1016/0022-5193\(74\)90202-1](https://doi.org/10.1016/0022-5193(74)90202-1)
- Jiang, Z. (2025). Mooring design for floating wind turbines: A review. *Renewable and Sustainable Energy Reviews*, 212, 115231. <https://doi.org/10.1016/j.rser.2024.115231>
- Ketten DR. 2000. Cetacean ears. In: Au WWL, Fay RR, Popper AN (Eds). *Hearing by Whales and Dolphins*. New York, NY: Springer.
- Kim D. 2007. Prey detection mechanism of elasmobranchs. *Biosystems*, 87: 322–31.
- Kino M, Miayzaki T, Iwami T, and Kohbara J. 2009. Retinal topography of ganglion cells in immature ocean sunfish, *Mola mola*. *Environmental Biology of Fishes*, 85: 33–8. <https://doi.org/10.1007/s10641-009-9453-z>
- Kojeszewski, T., & Fish, F. E. (2007). Swimming kinematics of the Florida manatee (*Trichechus manatus latirostris*): Hydrodynamic analysis of an undulatory mammalian swimmer. *Journal of Experimental Biology*, 210(14), 2411–2418. <https://doi.org/10.1242/jeb.02790>
- Kot, B. W., Sears, R., Anis, A., Nowacek, D. P., Gedamke, J., & Marshall, C. D. (2012a). Behavioral responses of minke whales (*Balaenoptera acutorostrata*) to experimental fishing gear in a coastal environment. *Journal of Experimental Marine Biology and Ecology*, 413, 13–20. <https://doi.org/10.1016/j.jembe.2011.11.018>
- Kot, B. W., Sears, R., Anis, A., Nowacek, D. P., Gedamke, J., & Marshall, C. D. (2012b). Behavioral responses of minke whales (*Balaenoptera acutorostrata*) to experimental fishing gear in a coastal environment. *Journal of Experimental Marine Biology and Ecology*, 413, 13–20. <https://doi.org/10.1016/j.jembe.2011.11.018>
- Kramer, S., Hamilton, C., Spencer, G., & Ogston, H. (2015). Evaluating the Potential for Marine and Hydrokinetic Devices to Act as Artificial Reefs or Fish Aggregating Devices, Based on Analysis of Surrogates in Tropical, Subtropical, and Temperate U.S. West Coast and Hawaiian Coastal Waters (Report No. OCS Study BOEM 2015-021). Report by H.T. Harvey & Associates. Report for Office of Energy Efficiency and Renewable Energy (EERE).
- Kraus, S., Fasick, J., Werner, T., & McFarron, P. (2014). Enhancing the visibility of fishing ropes to reduce right whale entanglements. *Bycatch Reduction Engineering Program*, 1, 67–75.

10. References

- Land, M. F., & Nilsson, D.-E. (2012). *Animal eyes*. Oxford University Press.
- Lee, C. F., Fjermedal, S., & Ong, M. C. (2025). Design and comparative analysis of mooring systems for a combined wind and wave energy system at intermediate water depth. *Journal of Ocean Engineering and Science*, 10(4), 492–508. <https://doi.org/10.1016/j.joes.2024.11.002>
- Lee, M., Chung, J., Akers, R., Copping A. (2023). Monitoring tensile loads in mooring lines using quasi-distributed FBG sensors. Presented at the University Marine Energy Research Community 2023 Conference, Durham, NH, USA.
- Levenson, D. H., Eckert, S. A., Crognale, M. A., li, J. F. D., & Jacobs, G. H. (2004). Photopic spectral sensitivity of green and loggerhead sea turtles. *Ichthyology & Herpetology*, 2004(4), 908–914. <https://doi.org/10.1643/CP-03-217R1>
- Lin, M., & Yang, C. (2020). Ocean observation technologies: A review. *Chinese Journal of Mechanical Engineering*, 33(1), 32. <https://doi.org/10.1186/s10033-020-00449-z>
- Lisney, T. J., & Collin, S. P. (2007). Relative eye size in elasmobranchs. *Brain, Behavior and Evolution*, 69(4), 266–279. <https://doi.org/10.1159/000100036>
- Lutz, P. L., Musick, J. A., & Wyneken, J. (2002). *The biology of sea turtles. Volume II (1st ed.)*. CRC Press. <https://doi.org/10.1201/9781420040807>
- MacNicoll, M., Akers, R., & Goudey, C. (2017). Simulation of marine entanglement a software tool used to predict entanglement of leatherback turtles. *OCEANS 2017 - Anchorage*, 1–8. <https://ieeexplore.ieee.org/abstract/document/8232193>
- McFarland, W. N. (1971). Cetacean visual pigments. *Vision Research*, 11(10), 1065-IN2. [https://doi.org/10.1016/0042-6989\(71\)90113-1](https://doi.org/10.1016/0042-6989(71)90113-1)
- Moein Bartol, S., & Musick, J. A. (2003). Sensory biology of sea turtles. In *The biology of sea turtles (Vol. 2)*. CRC Press.
- Moore, A. M., Hartstone-Rose, A., & Gonzalez-Socoloske, D. (2022). Review of sensory modalities of sirenians and the other extant Paenungulata clade. *The Anatomical Record*, 305(3), 715–735. <https://doi.org/10.1002/ar.24741>

10. References

- Moore, M. J., & van der Hoop, J. M. (2012). The painful side of trap and fixed net fisheries: Chronic entanglement of large whales. *Journal of Marine Sciences*, 2012(1), 230653. <https://doi.org/10.1155/2012/230653>
- Myrberg, A. A. (2001). The acoustical biology of elasmobranchs. *Environmental Biology of Fishes*, 60(1), 31–46. <https://doi.org/10.1023/A:1007647021634>
- Myrberg, A. A., Gordon, C., & Klimley, P. A. (1976). Attraction of free ranging sharks by low frequency sound, with comments on its biological significance. *Sound Reception in Fish*, 205–228.
- National Marine Fisheries Service. 2024a. National Marine Fisheries Service: Summary of Marine Mammal Protection Act Acoustic Thresholds. NOAA.
- National Marine Fisheries Service. (2024b). Update to: Technical Guidance for Assessing the Effects of Anthropogenic Sound on Marine Mammal Hearing (Version 3.0): Underwater and InAir Criteria for Onset of Auditory Injury and Temporary Threshold Shifts. (NOAA Technical Memorandum No. NMFS-OPR-71; p. 182). U.S. Dept. of Commer., NOAA.
- Newton KC, Gill AB, and Kajiura SM. 2019. Electroreception in marine fishes: chondrichthyans. *Journal of Fish Biology*, 95: 135–54.
- Nielsen, T. P., Wahlberg, M., Heikkilä, S., Jensen, M., Sabinsky, P., & Dabelsteen, T. (2012). Swimming patterns of wild harbour porpoises *Phocoena phocoena* show detection and avoidance of gillnets at very long ranges. *Marine Ecology Progress Series*, 453, 241–248. <https://doi.org/10.3354/meps09630>
- NOAA Fisheries. (2022). Approved weak inserts for the Atlantic large whale take reduction plan. <https://www.fisheries.noaa.gov/new-england-mid-atlantic/marine-mammal-protection/approved-weak-inserts-atlantic-large-whale-take#lazy-or-4-tuck-and-3-tuck-splices>
- NOAA Fisheries. (2025a, February 19). White shark (Alaska, New England/Mid-Atlantic, Pacific Islands, Southeast, West Coast). NOAA. <https://www.fisheries.noaa.gov/species/white-shark>
- NOAA Fisheries. (2025b, February 26). Sharks in Atlantic, Gulf, and Caribbean Coastal Waters (New England/Mid-Atlantic, Southeast). NOAA. <https://www.fisheries.noaa.gov/atlantic-highly-migratory-species/sharks-atlantic-gulf-and-caribbean-coastal-waters>

10. References

- NOAA Fisheries. (2025c, March 4). Harbor Porpoise (Alaska, New England/Mid-Atlantic, Southeast, West Coast). NOAA. <https://www.fisheries.noaa.gov/species/harbor-porpoise>
- NOAA Fisheries. (2025d, March 5). Pacific Blue Marlin (Pacific Islands). NOAA. <https://www.fisheries.noaa.gov/species/pacific-blue-marlin>
- NOAA Fisheries. (2025e, March 6). Common Bottlenose Dolphin (New England/Mid-Atlantic, Pacific Islands, Southeast, West Coast). NOAA. <https://www.fisheries.noaa.gov/species/common-bottlenose-dolphin>
- NOAA Fisheries. (2025f, March 20). North Atlantic Swordfish (New England/Mid-Atlantic, Southeast). NOAA. <https://www.fisheries.noaa.gov/species/north-atlantic-swordfish>
- NOAA Fisheries. (2025g, April 3). Western Atlantic Bluefin Tuna (New England/Mid-Atlantic, Southeast). NOAA. <https://www.fisheries.noaa.gov/species/western-atlantic-bluefin-tuna>
- NOAA Fisheries. (2025h, May 8). Harbor Seal (Alaska, New England/Mid-Atlantic, Southeast, West Coast). NOAA. <https://www.fisheries.noaa.gov/species/harbor-seal>
- NOAA Fisheries. (2025i, May 22). Gray Seal (New England/Mid-Atlantic). NOAA. <https://www.fisheries.noaa.gov/species/gray-seal>
- NOAA Fisheries. (2025j, May 27). Sperm Whale (Alaska, New England/Mid-Atlantic, Pacific Islands, Southeast, West Coast). NOAA. <https://www.fisheries.noaa.gov/species/sperm-whale>
- NOAA Fisheries. (2025k, May 29). Kemp's Ridley Turtle (New England/Mid-Atlantic, Southeast). NOAA. <https://www.fisheries.noaa.gov/species/kemps-ridley-turtle>
- NOAA Fisheries. (2025l, May 29). Loggerhead Turtle (New England/Mid-Atlantic, Pacific Islands, Southeast, West Coast). NOAA. <https://www.fisheries.noaa.gov/species/loggerhead-turtle>
- NOAA Fisheries. (2025m, June 20). Atlantic Shortfin Mako Shark (New England/Mid-Atlantic, Southeast). NOAA. <https://www.fisheries.noaa.gov/species/atlantic-shortfin-mako-shark>

10. References

- NOAA Fisheries. (2025n, July 9). Humpback Whale (Alaska, New England/Mid-Atlantic, Pacific Islands, Southeast, West Coast). NOAA. <https://www.fisheries.noaa.gov/species/humpback-whale>
- NOAA Fisheries. (2025o, July 16). Green Turtle (New England/Mid-Atlantic, Pacific Islands, Southeast, West Coast). NOAA. <https://www.fisheries.noaa.gov/species/green-turtle>
- NOAA Fisheries. (2025p, August 18). Atlantic Blacktip Shark (New England/Mid-Atlantic, Southeast). NOAA. <https://www.fisheries.noaa.gov/species/atlantic-blacktip-shark>
- NOAA Fisheries. (2025q, September 4). Leatherback Turtle (Alaska, New England/Mid-Atlantic, Pacific Islands, Southeast, West Coast). NOAA. <https://www.fisheries.noaa.gov/species/leatherback-turtle>
- NOAA Fisheries. (2025r, September 4). North Atlantic Right Whale (New England/Mid-Atlantic, Southeast). NOAA. <https://www.fisheries.noaa.gov/species/north-atlantic-right-whale>
- oceansunfish.org. (n.d.). Species and Distribution | Ocean Sunfish. <https://oceansunfish.org/species-and-distribution/>
- ORJIP. (2022). Information note: Encounters of marine animals with mooring systems and subsea cables (pp. 1–19). Offshore Renewables Joint Industry Programme.
- Pope, E. C., Hays, G. C., Thys, T. M., Doyle, T. K., Sims, D. W., Queiroz, N., Hobson, V. J., Kubicek, L., & Houghton, J. D. R. (2010). The biology and ecology of the ocean sunfish *Mola mola*: A review of current knowledge and future research perspectives. *Reviews in Fish Biology and Fisheries*, 20(4), 471–487. <https://doi.org/10.1007/s11160-009-9155-9>
- Potter, I. (2010). Movement and behavior of ocean sunfish, *Mola mola*, in the northwest Atlantic. University of New Hampshire, doctoral dissertation. <https://scholars.unh.edu/cgi/viewcontent.cgi?article=1602&context=dissertation>
- Raschi, W. C., Aadlond, C., & Keithar, E. D. (2001). A morphological and functional analysis of the ampullae of Lorenzini in galeoid sharks. In *Sensory Biology of Jawed Fishes: New Insights* (pp. 279–316).

10. References

- Reep, R. L., Marshall, C. D., Stoll, M. L., & Whitaker, D. M. (1998). Distribution and innervation of facial bristles and hairs in the Florida manatee (*Trichechus manatus latirostris*). *Marine Mammal Science*, 14(2), 257–273. <https://doi.org/10.1111/j.1748-7692.1998.tb00715.x>
- Reichmuth C, Holt MM, Mulsow J, et al. 2013. Comparative assessment of amphibious hearing in pinnipeds. *Journal of Comparative Physiology A*, 199: 491–507.
- Ridgway, S. H., Wever, E. G., McCormick, J. G., Palin, J., & Anderson, J. H. (1969). Hearing in the giant sea turtle, *Chelonia mydas*. *Proceedings of the National Academy of Sciences*, 64(3), 884–890. <https://doi.org/10.1073/pnas.64.3.884>
- Rivera, G. (2009). Hydrodynamics of freshwater turtles: maneuverability, stability, and effects of shell shape. Clemson University, doctoral dissertation. https://open.clemson.edu/all_dissertations/480
- Rycyk, A. (2013). Manatee behavioral response to approaching boats. Florida State University, doctoral dissertation. <https://www.proquest.com/docview/1447685630/abstract/C2A356A519AB4707PQ/1>
- Schusterman, R. J. (1972). Visual acuity in pinnipeds. In H. E. Winn & B. L. Olla (Eds.), *Behavior of marine animals: Current perspectives in research, volume 2: Vertebrates* (pp. 469–492). Springer US. https://doi.org/10.1007/978-1-4684-0910-9_8
- Shadwick, R. E., Schiller, L. L., & Fudge, D. S. (2013). Physiology of swimming and migration in tunas. In A. P. Palstra & J. V. Planas (Eds.), *Swimming physiology of fish: towards using exercise to farm a fit fish in sustainable aquaculture* (pp. 45–78). Springer. https://doi.org/10.1007/978-3-642-31049-2_3
- Sims, D. W. (2000). Filter-feeding and cruising swimming speeds of basking sharks compared with optimal models: They filter-feed slower than predicted for their size. *Journal of Experimental Marine Biology and Ecology*, 249(1), 65–76. [https://doi.org/10.1016/S0022-0981\(00\)00183-0](https://doi.org/10.1016/S0022-0981(00)00183-0)
- Southwood, A., Fritsches, K., Brill, R., & Swimmer, Y. (2008). Sound, chemical, and light detection in sea turtles and pelagic fishes: Sensory-based approaches to bycatch reduction in longline fisheries. *Endangered Species Research*, 5, 225–238. <https://doi.org/10.3354/esr00097>

10. References

- Swimmer, Y., & Brill, R. (2006). Sea turtle and pelagic fish sensory biology: Developing techniques to reduce sea turtle bycatch in longline fisheries (No. NMFS-PIFSC-7; p. 117). NOAA. https://repository.library.noaa.gov/view/noaa/3508/noaa_3508_DS1.pdf#page=108
- Thomson, K., & Simanek, D. (1977). Body form and locomotion in sharks. *American Zoologist*, 17(2), 343–354. <https://doi.org/10.1093/icb/17.2.343>
- U.S. Fish & Wildlife Service. (2025, September 17). Manatee (*Trichechus manatus*). <https://www.fws.gov/species/manatee-trichechus-manatus>
- Venkatesan, R., Ramesh, K., Kishor, A., Vedachalam, N., & Atmanand, M. A. (2018). Best practices for the ocean moored observatories. *Frontiers in Marine Science*, 5. <https://doi.org/10.3389/fmars.2018.00469>
- Wang, J., Barkan, J., Fislser, S., Godinez-Reyes, C., & Swimmer, Y. (2013). Developing ultraviolet illumination of gillnets as a method to reduce sea turtle bycatch. *Biology Letters*, 9(5), 20130383. <https://doi.org/10.1098/rsbl.2013.0383>
- Wartzok D and Ketten DR. 1999. Marine mammal sensory systems. *Biology of Marine Mammals*, 1, 117-175.
- Weber, P. W., Howle, L. E., Murray, M. M., Reidenberg, J. S., & Fish, F. E. (2014). Hydrodynamic performance of the flippers of large-bodied cetaceans in relation to locomotor ecology. *Marine Mammal Science*, 30(2), 413–432. <https://doi.org/10.1111/mms.12040>
- Weller, S. D., Johanning, L., Davies, P., & Banfield, S. J. (2015). Synthetic mooring ropes for marine renewable energy applications. *Renewable Energy*, 83, 1268–1278. <https://doi.org/10.1016/j.renene.2015.03.058>
- Wilson, C., & Wilding, C. (2017). Basking shark (*Cetorhinus maximus*). *Marine Information Network*. <https://dx.doi.org/10.17031/marlin.sp.1438.2>
- Woodward, B., Winn, J., & Fish, F. (2006). Morphological specializations of baleen whales associated with hydrodynamic performance and ecological niche. *Journal of Morphology*, 267, 1284–1294. <https://doi.org/10.1002/jmor.10474>
- Xu, S., Wang, S., & Guedes Soares, C. (2019). Review of mooring design for floating wave energy converters. *Renewable and Sustainable Energy Reviews*, 111, 595–621. <https://doi.org/10.1016/j.rser.2019.05.027>
- Zier, J., & Gaydos, J. (2014). Harbor seal species profile. UC Davis Karen C. Drayer Wildlife Health Center.



Thank you

lenaig.hemery@pnnl.gov

