

BLUMARA

FINITE ELEMENT ANALYSIS TO ASSESS FISH MORTALITY FROM INTERACTIONS WITH
TIDAL TURBINE BLADES – FINAL REPORT

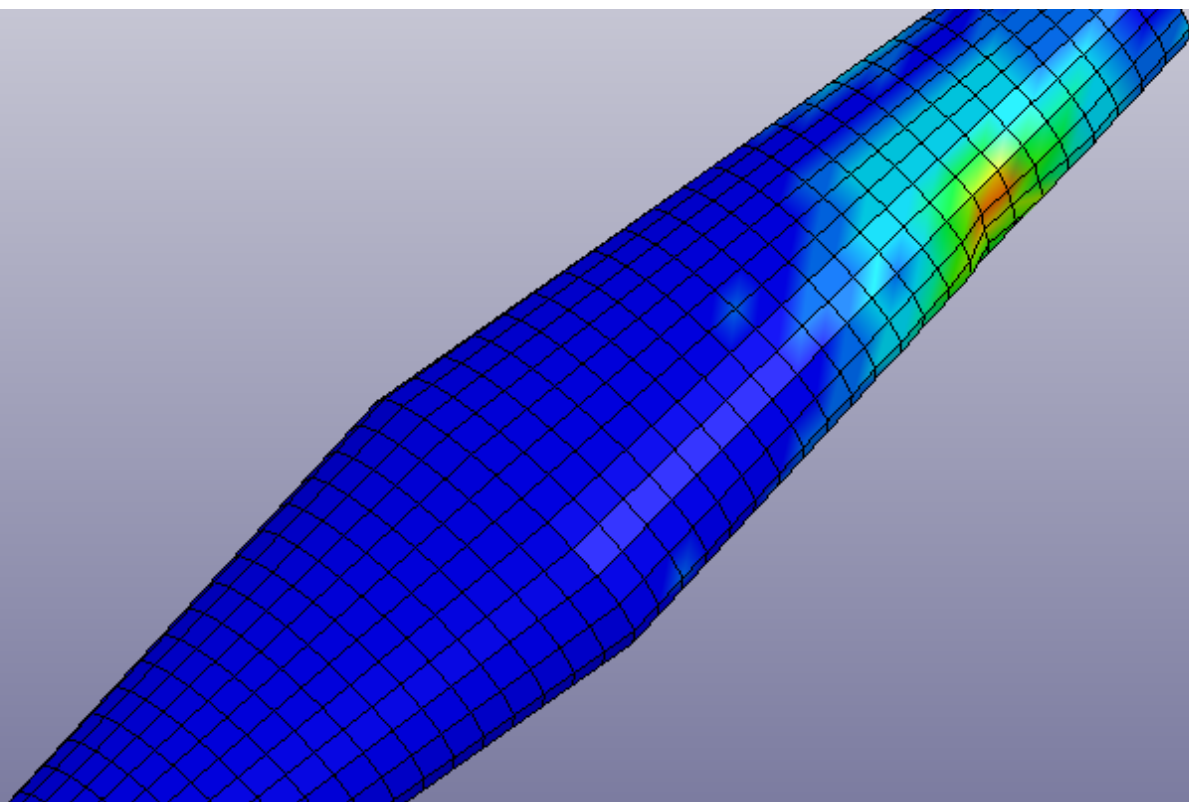

**Prepared by N. Fyffe, Blumara Corp. for the
Offshore Energy Research Association**

**Commenced 15 March 2017
Submitted on 23 April 2018**

23 April 2018

The primary objective of this study was achieved in validating the utility of the finite element model as an effective tool in conducting fish and blade impact simulation research.

FOREWORD

It is important to note that the results of this study do NOT take into consideration fish avoidance behaviour; that is, the fish's ability to maneuver out of the way of the blade or swim at a different relative speed to the turbine blade. The laboratory trials did not account for measuring fish avoidance behaviour as this was beyond the scope of this project. However, it is recommended that future research on fish-blade interaction simulations should consider this important variable.

DISCLAIMER

Blumara Corp. makes no warranty and assumes no liability for the accuracy or validity of any results contained in this report. Blumara Corp. shall not be liable for loss of profit, loss of business, or other financial loss that may be caused directly or indirectly by the calculations, data, conclusions, and recommendations when used for any purpose or use, or due to any defect or deficiency therein.

Any questions relating to the use or interpretation of this report and its application should be directed to:

Blumara Corp.
6 Glengary Drive
Halifax NS
Tel (902) 955-7300

23 April 2018

1 Executive Summary

This project has investigated the use of computer simulations, in the form of finite element analysis to assess fish mortality from impacts with tidal turbine blades at various flow speeds and turbine operating conditions. In order to perform these analyses, an idealized fish finite element model was developed using previous research on the mechanical properties of fish and calibrated using laboratory tests to obtain strain data from fish impacts on a flat aluminum plate.

A further objective of the project was to assess the suitability of strain gauges as a method to monitor fish impacts with a tidal turbine.

Laboratory tests were performed in the Dalhousie University Flume tank over the summer of 2017 using fish selected for their relevance to the high energy sites of the Minas Passage in Nova Scotia. Analysis of the test data was completed in October 2017. Results from the laboratory tests showed that it was possible to differentiate when an object hits the plate from the background “noise” of the flow and turbulence of the environment, however “noise” obscured several of the smaller fish impact tests and strain gauge measurements would likely be problematic in real turbine operating conditions.

Finite element models were developed and analyzed through the winter of 2017/18. The initial analyses focused on simulating laboratory tests in order to calibrate the fish finite element model which was developed based on the properties of a striped bass. The comparison of finite element analysis results to strain data collected in the laboratory was favorable and allowed the project to progress to the finite element analysis of tidal turbine blade and fish interactions which were conducted in early 2018.

The results from the finite element analyses of the fish impact with a tidal turbine blade showed that in all but the slowest impact speed (fish impacting the blade at 2 m/s) with no blade rotation, a significant quantity of finite elements in the fish model exceeded the strain or stress failure criteria. As a result it was concluded that there is a high probability of fish mortality in the event that it impacts an operational turbine blade.

Recommendations for related future work include testing of strain gauge measurement of impacts in real turbine operating conditions, research into technology and techniques to improve analysis of strain gauge data in “noisy” flow environments, investigation into whether strain data from fish impacts can be distinguished from impacts of other objects, refinement of finite element techniques to analyze larger biological object impacts and investigation into the use of finite element analysis to assess effects of impacts on the turbine blades themselves.

23 April 2018

2 Acknowledgements

Blumara Corp. would like to thank the following people and organizations for their help and support in this project:

- OERA
- Nova Scotia Department of Energy
- Katherine MacCaul, Blumara Corp.
- John Batt, Aquatron – Dalhousie University
- Dr. Anna Redden and Dr. Richard Karsten, Acadia University

23 April 2018

3 Contents

| | | |
|-------|--|----|
| 1 | Executive Summary | 3 |
| 2 | Acknowledgements | 4 |
| 3 | Contents | 5 |
| 4 | List of Figures | 6 |
| 5 | Introduction | 7 |
| 6 | Methodology | 8 |
| 6.1 | Laboratory Tests | 8 |
| 6.1.1 | Fish Species Selection | 8 |
| 6.1.2 | Test Setup | 8 |
| 6.1.3 | Test Program | 11 |
| 6.2 | Finite Element Analysis | 11 |
| 6.2.1 | Geometry | 11 |
| 6.2.2 | Element Properties | 12 |
| 6.2.3 | Material Properties | 12 |
| 6.2.4 | Boundary Conditions/Applied Loads | 14 |
| 7 | Results and Discussion | 17 |
| 7.1 | Effectiveness of strain gauge measurement | 17 |
| 7.2 | Finite Element Model Validation | 17 |
| 7.2.1 | Results | 18 |
| 7.2.2 | Discussion | 21 |
| 7.3 | Fish Mortality due to Turbine Blade Impact | 23 |
| 7.3.1 | Results | 23 |
| 7.3.2 | Discussion | 27 |
| 8 | Recommendations | 28 |
| 9 | References | 29 |

23 April 2018

4 List of Figures

| | |
|--|----|
| Figure 1 - Flume Tank at Dalhousie University..... | 9 |
| Figure 2 - Fish used for laboratory tests | 9 |
| Figure 3 - Plate and Strain Gauge Arrangement..... | 10 |
| Figure 4 - Laboratory Test Simulation Finite Element Model | 15 |
| Figure 5 - Turbine Blade Impact Finite Element Model (no blade rotation)..... | 15 |
| Figure 6 - Turbine Blade Impact Finite Element Model (blade rotating)..... | 16 |
| Figure 7 - Striped Bass Impact with Aluminum Plate during Laboratory Tests | 18 |
| Figure 8 - Actual vs Simulated Striped Bass Impact on Plate at 0.2m/s, Load Case A1..... | 18 |
| Figure 9 - FEA, Maximum Strain, Load Case A1 | 19 |
| Figure 10 - Actual vs Simulated Striped Bass Impact on Plate at 0.3m/s, Load Case A2.... | 19 |
| Figure 11 - FEA, Maximum Strain, Load Case A2 | 20 |
| Figure 12 - Actual vs Simulated Striped Bass Impact on Plate at 0.4m/s, Load Case A3.... | 20 |
| Figure 13 - FEA, Maximum Strain, Load Case A3 | 21 |
| Figure 14 - FEA, Maximum Strain in Fish, Load Case A3 | 22 |
| Figure 15 - FEA, Maximum Strain, Load Case B1 | 23 |
| Figure 16 - FEA, Post-impact Strain and Element Deletion, Load Case B2..... | 24 |
| Figure 17 - FEA, Post-impact Strain and Element Deletion, Load Case B3..... | 24 |
| Figure 18 - FEA, Post-impact Strain and Element Deletion, Load Case C1..... | 25 |
| Figure 19 - FEA, Post-impact Strain and Element Deletion, Load Case C2..... | 25 |
| Figure 20 - FEA, Post-impact Strain and Element Deletion, Load Case C3..... | 26 |
| Figure 21 - FEA, Mid-impact Strain and Element Deletion, Load Case C3..... | 26 |

23 April 2018

5 Introduction

Tidal energy turbines are one of the most intuitive contenders for significant collision risks with marine life. Collisions are most likely in high flow environments where flows can combine with swimming speeds to produce high approach velocities with consequently reduced avoidance or evasion response times. Stakeholder concerns are focused on the impact on marine life and, in particular, fish mortality as a result of tidal turbine operation. As a result, there is significant pressure for the tidal energy industry to provide the necessary evidence, analysis of environmental impact, and mitigation and monitoring plans required for site consenting, regulatory approvals and social licence to enable the tidal energy industry to advance beyond a demonstration project.

Although proponents of the tidal energy industry and previous research (Bevelhimer, et al. 2016) suggests that there will not be significant harm to fish in relation to tidal energy devices, to date there has been a lack of suitable methodologies to investigate and obtain conclusive evidence that there is little to no fish mortality from collisions with the tidal turbine blades. Actual monitoring of fish interactions with the turbine blades has proven difficult, and further still, monitoring of the level of fish mortality around a turbine has never been accomplished. The reality is, the technology isn't readily available that can collect this kind of data. Cameras are an obvious choice, however their operation is severely limited in the low visibility of the Minas Passage. Sonar is another option, however the field of view, resolution and images obscured by turbulent wakes, limit monitoring to observation of the presence of fish, not whether a fish strikes a blade and more importantly what consequence this has on the fish. As a result there is little data or research available to support proponents claims that tidal turbines will not be harmful to fish when in operation.

One solution to this problem is the use of computer modeling. If a robust, realistic and validated computer simulation of fish encounters with a turbine can be created, then simulation data can provide valuable evidence on the outcome of such scenarios. Simulation of tidal turbines in relation to environment effects has so far involved numerical modeling using Computational Fluid Dynamics to assess effects on fish from pressure changes around a tidal turbine; and tidal turbine developers are likely considering and investigating the results of an impact from an object on the their technologies, however there is limited research in whether a tidal turbine blade strike will result in the mortality of a fish. Therefore this project aims to address a gap in theoretical analysis, by simulating a fish moving towards and impacting a tidal turbine blade and providing analysis on the consequences of that impact to the fish.

The project objectives were to:

- Assess whether finite element methods can be used to simulate turbine blade impacts with fish and other marine life,

23 April 2018

- Provide an indication of whether turbine blade impacts are likely to result in fish mortality,
- Assess whether strain gauges can be used as a way to monitor fish collisions with a turbine.

6 Methodology

6.1 Laboratory Tests

6.1.1 Fish Species Selection

Initially, a list of fish species that would potentially be in the vicinity of a tidal turbine in the Minas Passage, NS was created. Each species was assigned an economic value, population size and level of endangerment (Government of Canada n.d.). Then by assigning a significance factor to each parameter, a clear gap of large size, small size, low and high importance species was determined. It was subsequently determined that shad, mackerel and striped bass would be optimal fish for use in the laboratory testing as they represent species present in the Minas Passage and were readily available during the test period.

6.1.2 Test Setup

The flume tank at Dalhousie University was used to perform the laboratory tests. The flume tank was able to produce flow speeds of 0.4m/s and had a cross sectional water area of 50cm by 36cm. Although this is not representative of the flow speed in the Minas Passage, it provides enough flow to create an impact between fish and an inanimate object that can be used to calibrate the finite element model. The finite element model can then be used in simulations of Minas Passage level flows.

23 April 2018

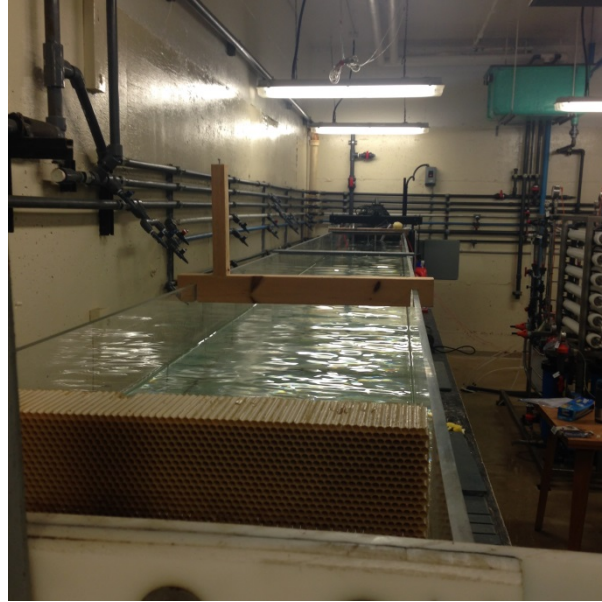

Figure 1 - Flume Tank at Dalhousie University

The test setup required the following other items:

- Fish or objects to simulate fish
- An object for the fish to impact
- A process for measuring and recording strain

The fish obtained for the testing (shad, mackerel and striped bass) were purchased from shops and direct from fishermen. Figure 2 shows the fish specimens that were used in testing.

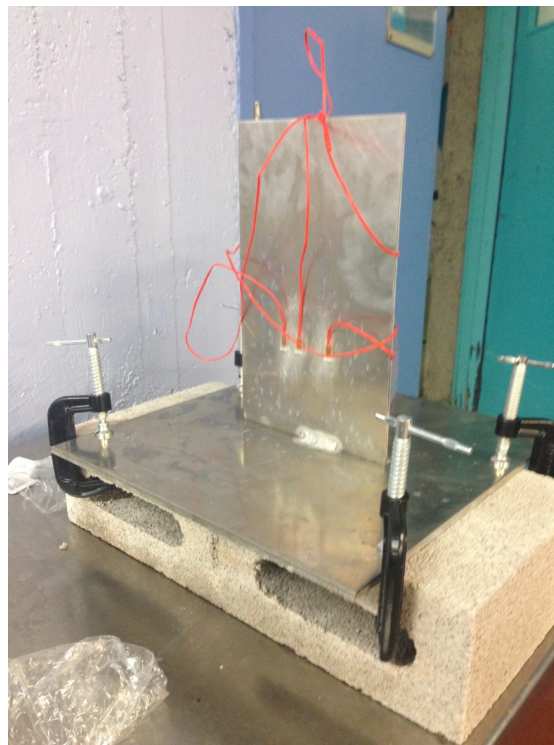

*Figure 2 - Fish used for laboratory tests
(top left: shad, bottom left: striped bass, right: mackerel)*

23 April 2018

Several different options were considered for a suitable object to use for the impact surface. Initially an object that was similar to a turbine blade was considered, perhaps using a model of a turbine blade previously constructed for research or using a propeller of a boat. Instead it was decided that an accurate representation of a turbine blade was not required at this stage, as the objective was to calibrate only the fish finite element model. Therefore an assembly of two welded plates shown in figure 4 was used to simplify the calibration of the finite element analysis. Aluminum 5052 was chosen as it is a material that is commonly used in marine environments and is easily represented in the finite element model.

To measure strain, water proof pre-wired strain gauges were used in three different configurations in order to test which setup might be most effective for a tidal turbine monitoring setup. The different configurations were full bridge (four strain gauges), half bridge (two strain gauges) and quarter bridge (one strain gauge)). The data acquisition device, the DSCUSB, was chosen for its simplistic use, suitable sampling rate (500Hz) and low cost.



*Figure 3 - Plate and Strain Gauge Arrangement
(note: the strain gauge leads were positioned out of the impact region during the actual tests)*

23 April 2018

6.1.3 Test Program

A series of tests was conducted where fish were released into the flow and allowed to impact the plate surface with flow speed increased incrementally from 0.1 m/s to the maximum flow of 0.4m/s. Plate orientation generally remained constant being perpendicular to the flow.

In order to compare with results from the finite element analysis, the raw output provided by the data acquisition system was converted to true strain using the following formula:

$$\varepsilon = \ln \left(1 + \frac{V_r}{GF} \right)$$

Where V_r is the ratio of input to output voltage measure directly from the strain gauge, and; GF is the gauge factor which is the ratio of relative change in electrical resistance to strain.

The video recordings obtained from the laboratory tests were reviewed in order to select a suitable example of a head-on transient impact with the shad, mackerel and striped bass. The corresponding calculated strain data was then used to compare with the strain data obtained from the finite element analysis, thus calibrating the finite element model.

6.2 **Finite Element Analysis**

Two finite element model configurations were used in this project. Firstly, a model to simulate the laboratory tests was created and analysis performed in order to validate the parameters used for the fish finite element model against test data. The fish finite element model was then used in the second finite element model configuration which simulates tidal turbine blade and fish impacts.

LS-Dyna, an explicit dynamic finite element code, widely used for impact and crash analyses, was utilized for all the simulations performed for this project.

6.2.1 Geometry

The proportions of the “fish” model were based on the fish used for in the laboratory tests. The tail and fins of the fish were excluded from the model as they were deemed to be inconsequential to the impact simulations.

The geometry of the aluminum impact plate was identical to that used in the laboratory tests, however the base plate was made slightly smaller to reduce the computational time without any significant detriment to the results.

23 April 2018

For the turbine blade impact analysis, a single turbine blade was modelled with a 4.8m and 2.25m outer and inner diameter respectively. The blade was therefore approximately 1.25m long, 670mm wide and 25mm thick. These dimensions are based on known data of a turbine blade used in previous finite element analysis (Carlson, et al. 2014).

The water in the tank and surrounding the turbine blade was not explicitly modelled to reduce complexity and reduce computational time, rather it's effects were accounted for using an added mass method (Dong 1978) as described in section 6.2.3.

6.2.2 Element Properties

For the fish model, layer of 2D shell elements with a thickness of 0.3mm were generated which represented the fish scale structure on the outer surface of the fish.

3D solid elements were used underneath the shell elements to represent the underlying dermis and flesh that support the fish scale structure.

2D Shell elements were used to represent the aluminum plate.

For the turbine blade analyses, the blade was modelled using 3D solid elements.

The models were meshed with an element length of approximately 3mm for the aluminum plate and 5mm and 17mm for the fish and turbine blade models respectively to reflect the desire to have greater accuracy of results in the object of interest, in this case the fish.

6.2.3 Material Properties

Previous studies have been conducted to determine the mechanical properties of fish¹, in particular for striped bass, which was conveniently used as the basis for determining the material properties of the fish finite element model. The determination of material properties for the fish scale structure was relatively straight forward as they can be assumed to behave in a linear elastic manner with published data available to suggest a level of stress and strain at which a fish scale is likely to fail (Zhu, et al. 2012). The mechanical properties of the supporting dermis/flesh, however, is assumed to behave in a hyperelastic manner, which necessitates a more complex material model. A Mooney-Rivlin model was chosen for the analysis which can accurately represent large deformations in materials such as skin, muscle and rubber. Material test data must be used to determine the parameters for defining the Mooney-Rivlin model, however no data was readily available for fish dermis or flesh. As a result, it was decided that parameters for a rubber or silicone type material, used as a substitute for soft tissue in other research (Mesa-Munera, et al. 2012), could be used as an

¹ (Szewciw and Barthelat 2016), (Vernerey, Musiket and Barthelat 2013), (Zhu, et al. 2012)

23 April 2018

approximation for the fish dermis and flesh finite elements. Suitable Mooney Rivlin parameters determined from test data for the silicone were used for the material model for the fish dermis/flesh elements and an assumed failure at a strain of 0.5 was used. Although this approximation of material properties makes determining damage to the fish material underneath the scale structure more uncertain, it still allows accurate modelling of the failure of the scale structure which by itself would be a likely indicator of significant injury to a fish.

The plate was fabricated from 5052-H32 aluminum and was modelled using elastic material properties equivalent to that particular grade of aluminum.

The turbine blade was modelled as a rigid material with similar properties to that of a composite or plastic resin (Carlson, et al. 2014).

As stated previously the water in the tank used for the laboratory tests was not explicitly modelled in the finite element analysis, instead fluid inertial forces due to the motion of the water and the fish in the tank were incorporated into the model. In order to account for these additional forces a simple “added mass” technique was used (Dong 1978), whereby additional distributed mass was added to the fish and plate finite element models. The calculation for the added mass used empirical formulae resulting in mass additions of 0.28kg and 3.07kg for the fish and plate respectively.

Table 1 - FEA Material Properties

| Material | Elastic Modulus (GPa) | Density (kg/mm ³) | Poisson's Ratio | C ₀₁ | C ₁₀ | Failure Criteria |
|--------------------------|-----------------------|-------------------------------|-----------------|-----------------|-----------------|---|
| Fish Scales | 0.85 | 2.250e-06 | 0.45 | N/A | N/A | 0.1 (strain), 0.05 GPa (Von Mises stress) |
| Fish Dermis/Flesh | N/A | 1.25e-06 | 0.49 | 7.461e-07 | 6.243e-07 | 0.5 |
| Aluminum 5052-H32 | 70.3 | 2.849e-05 | 0.33 | N/A | N/A | N/A |
| Turbine Blade | 7 | 1.200e-06 | 0.3 | N/A | N/A | N/A |

The moment of inertia of the turbine rotor was added to the finite element model of the blade, with the inertia calculated assuming the rotor is a solid disc with a mass of 6200 kg and diameter of 4.8 m (Carlson, et al. 2014).

As previously mentioned, the fish material properties were assigned a failure criteria in the finite element model. In order to give a more accurate simulation of the impact and to

23 April 2018

simplify the assessment of damage, the finite element analysis was set to “erode” elements that exceeded the assigned failure criteria which also aids in the analysis computation by deleting elements that could otherwise cause an analysis to terminate due to errors resulting from extremely large deformations or distortions. In this manner, damage to the fish could easily be observed in the results plots without having to assess raw values of strain or stress from the analysis.

6.2.4 Boundary Conditions/Applied Loads

The laboratory test simulations used a simple pinned constraint at the four corners of the base which prevented movement of the aluminum plate base. An initial velocity was applied to the fish model to represent the flow speeds at which the laboratory tests were conducted. The applied velocities are described in load cases A1 to A3 in Table 2.

The turbine blade impact simulations used a constraint on the turbine blade which allowed rotation/translation of the blade around its axis of rotation but prevented movement in other directions. Two different impact scenarios were considered for the turbine blade simulations, shown in Figure 5 and Figure 6. Firstly, the blade at a standstill and the fish impacting on the flat surface of the blade at varying velocities (see Figure 4), represented by load cases B1 to B3 in Table 2. Secondly, the fish initial velocity is fixed at 1m/s and the blade rotates at a range of speeds corresponding to start-up, average operating and highest operating speed of the turbine based on published data from previous analysis. These are represented by load cases C1 to C3 in Table 2.

Table 2 - Finite Element Analysis Applied Loads

| Load Case | Fish velocity | Blade RPM |
|-----------|---------------|-----------|
| A1 | 0.2m/s | n/a |
| A2 | 0.3m/s | n/a |
| A3 | 0.4m/s | n/a |
| B1 | 1m/s | 0 |
| B2 | 3m/s | 0 |
| B3 | 5m/s | 0 |
| C1 | 1m/s | 2 rpm |
| C2 | 1m/s | 8 rpm |
| C3 | 1m/s | 24 rpm |

23 April 2018

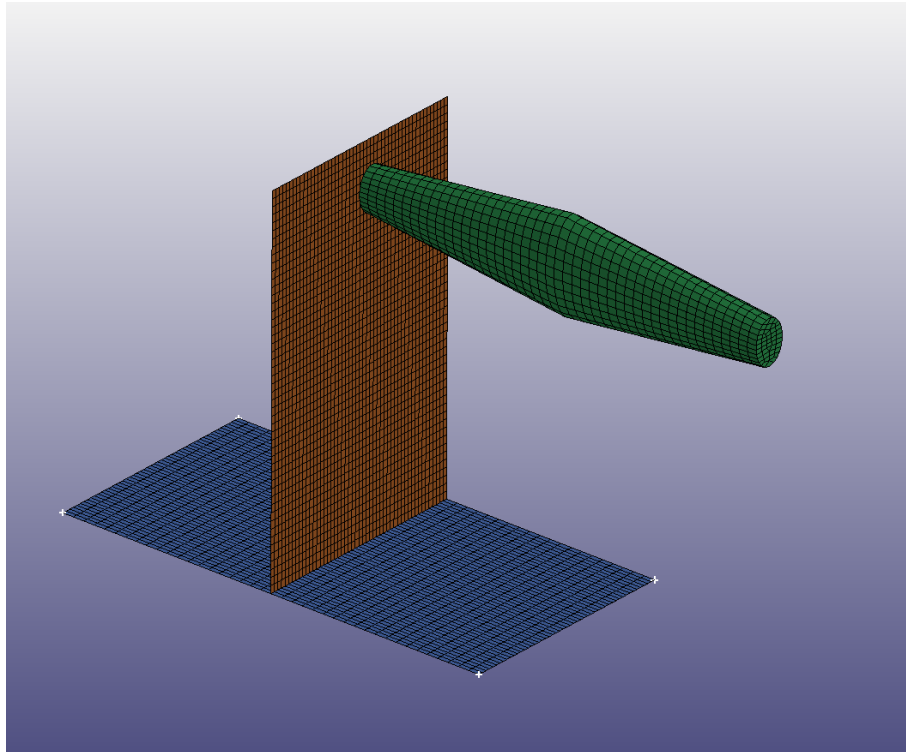

*Figure 4 - Laboratory Test Simulation Finite Element Model
(The fish model is shown in green and the aluminum plate and base are brown and blue respectively)*

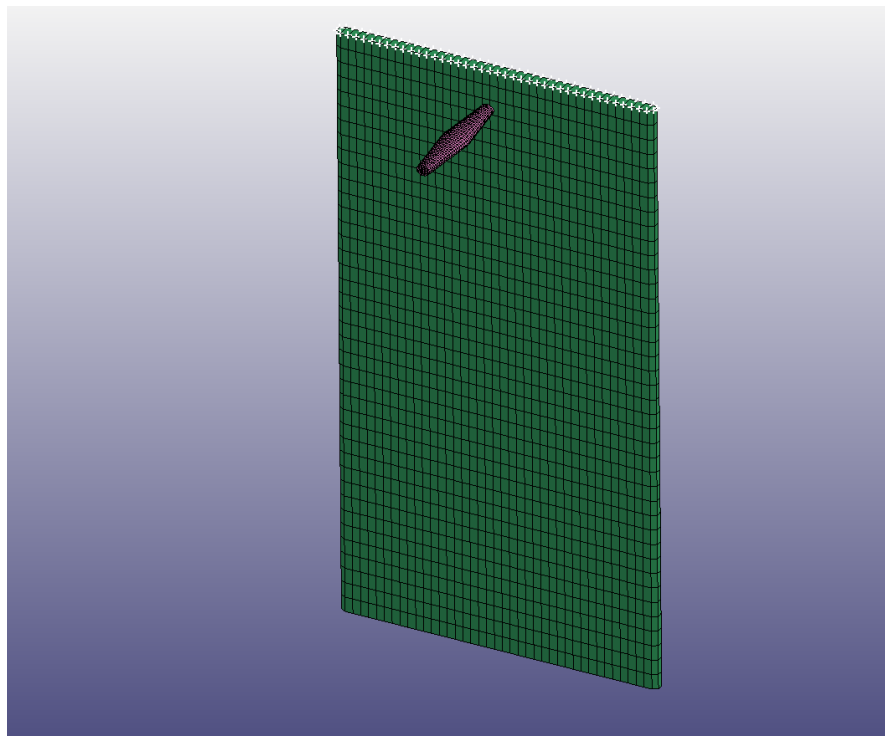

Figure 5 - Turbine Blade Impact Finite Element Model (no blade rotation)

23 April 2018

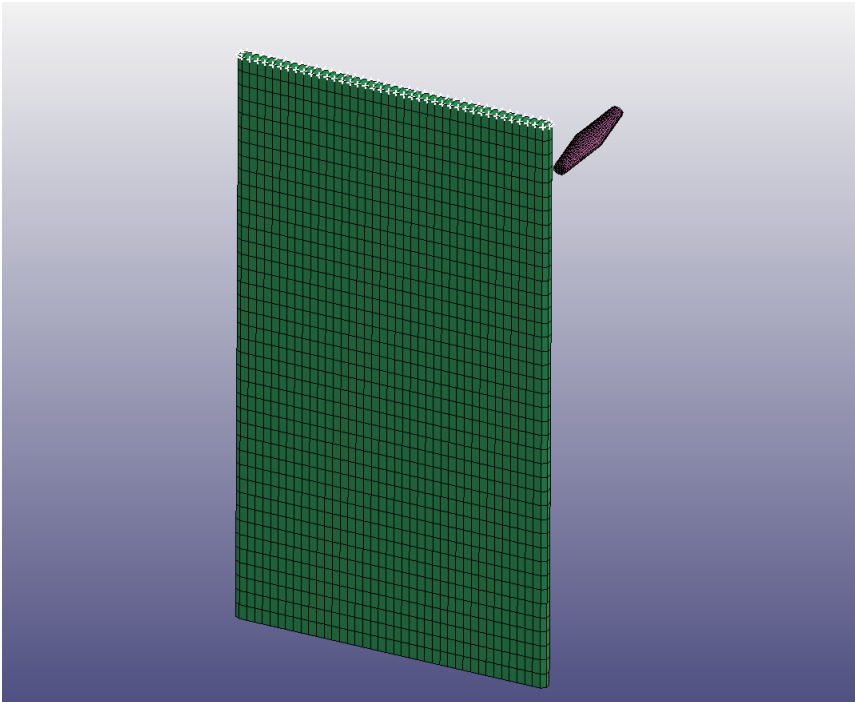

Figure 6 - Turbine Blade Impact Finite Element Model (blade rotating)

23 April 2018

7 Results and Discussion

7.1 Effectiveness of Strain Gauge Measurement

The initial laboratory tests investigated the effectiveness of different strain gauge arrangements (quarter, half and full bridge). It quickly became clear that the full bridge (four strain gauges) was the optimal configuration and provided a level sensitivity necessary to capture the brief impact events.

The results of the impact tests indicated that it is possible to differentiate when an object hits the plate from the background “noise” of the flow and turbulence of the environment, however obtaining suitable impact data from the smaller fish species was not possible. This was due to the force of the impact being indistinguishable from the background data, either because at slow speeds the impact did not generate enough “force” to register a change in strain on the strain gauges or at high speeds the data resulting from more turbulent flow obscured the impact event.

If these observations are extrapolated to the flow speeds and turbulence encountered at a turbine site, then “noise” in the data may preclude the use of strain gauges for measuring smaller fish species impacting a tidal turbine blade. However, without testing in real operating conditions, this is not conclusive.

Further investigation is needed and the use of more advanced instrumentation, data acquisition technology and improved data analysis techniques may yield results that allow strain gauges to be successfully used for monitoring impact events.

7.2 Finite Element Model Validation

The finite element simulation of the laboratory test was setup with the intention of simulating a head-on impact of the fish on the plate, however several of the laboratory test data sets were unsuitable for use in comparison to the finite element analysis due to events such as the fish missing the plate altogether, the fish impacting the plate in a sideways orientation and/or becoming stuck against the plate.

In addition the mackerel and shad tests failed to produce any useable data resulting from a suitable impact due to the impact not registering at the lowest speeds or the data being obscured by noise. The striped bass tests however, yielded good quality data sets from a number of suitable impacts. Three of these data sets representing three different fish velocities (0.2m/s, 0.3m/s and 0.4m/s) were then used to compare against the finite element model. Due to comparison laboratory test data only being available for the striped bass test,

23 April 2018

the finite element model was refined to ensure the geometry and properties of the model was similar to that of the striped bass used in the laboratory tests.

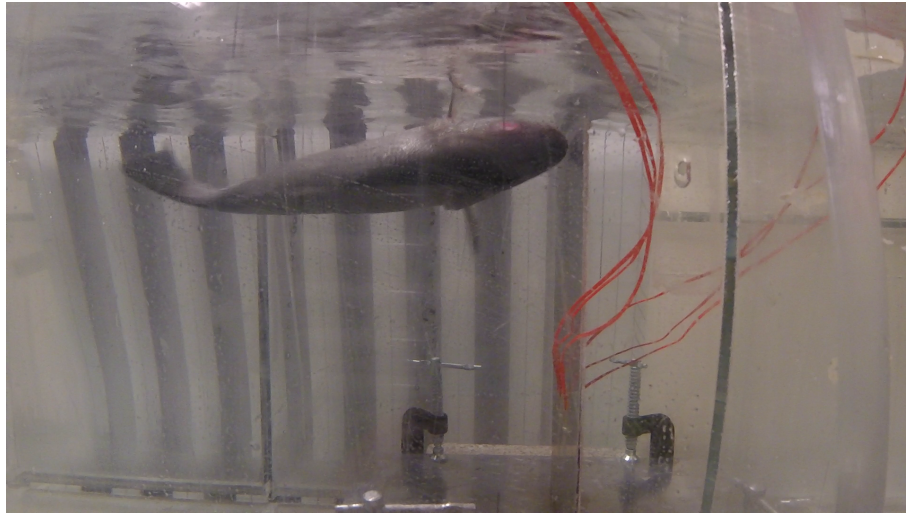

Figure 7 - Striped Bass Impact with Aluminum Plate during Laboratory Tests

The strain data from two elements representing the locations of the strain gauges mounted on the aluminum plate were outputted for comparison with the laboratory test data.

7.2.1 Results

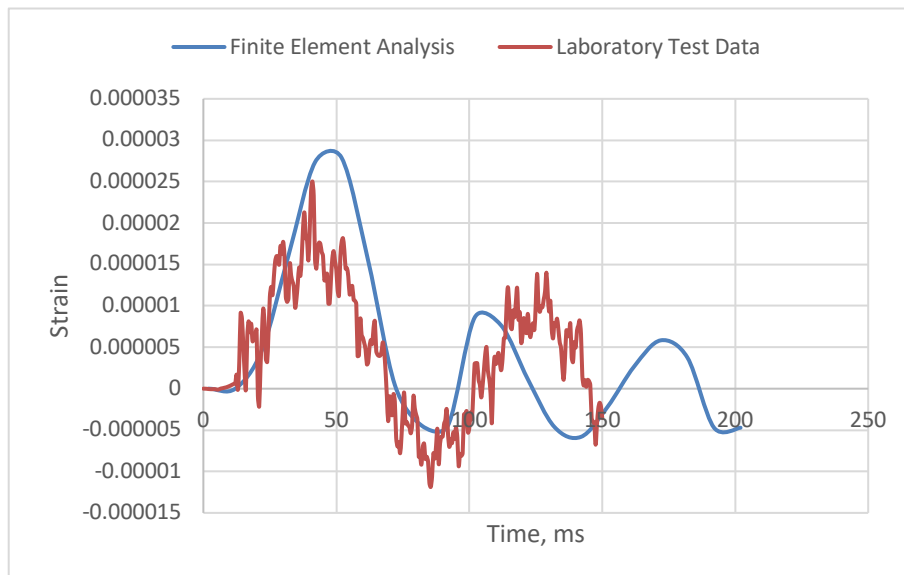

Figure 8 - Actual vs Simulated Striped Bass Impact on Plate at 0.2m/s, Load Case A1

23 April 2018

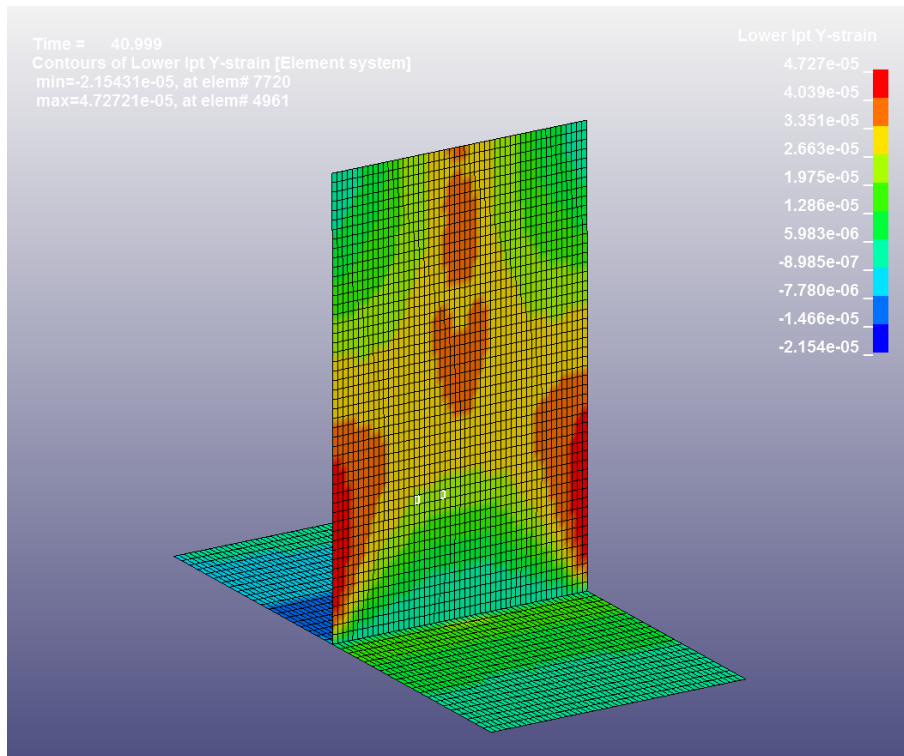

Figure 9 - FEA, Maximum Strain, Load Case A1
(Fish not shown for clarity, "strain gauge" element locations highlighted in white)

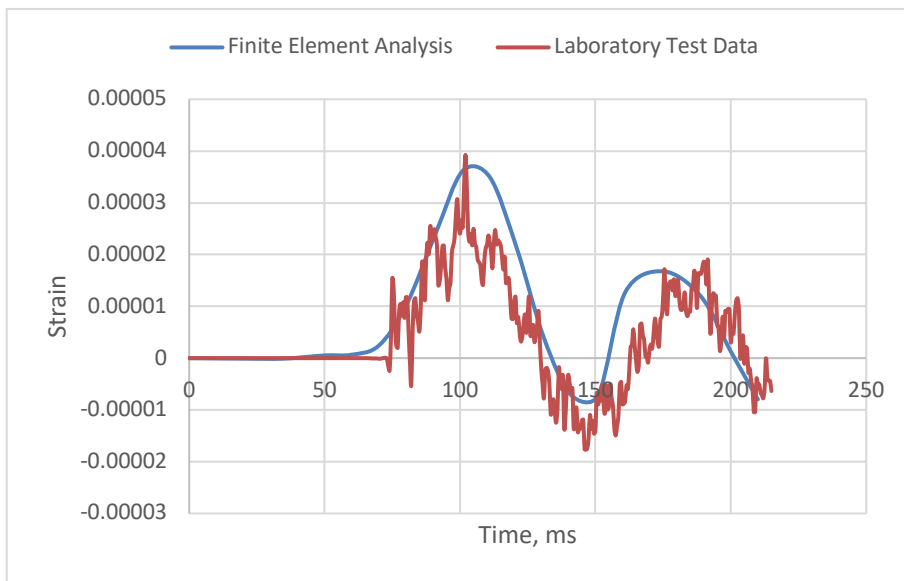

Figure 10 - Actual vs Simulated Striped Bass Impact on Plate at 0.3m/s, Load Case A2

23 April 2018

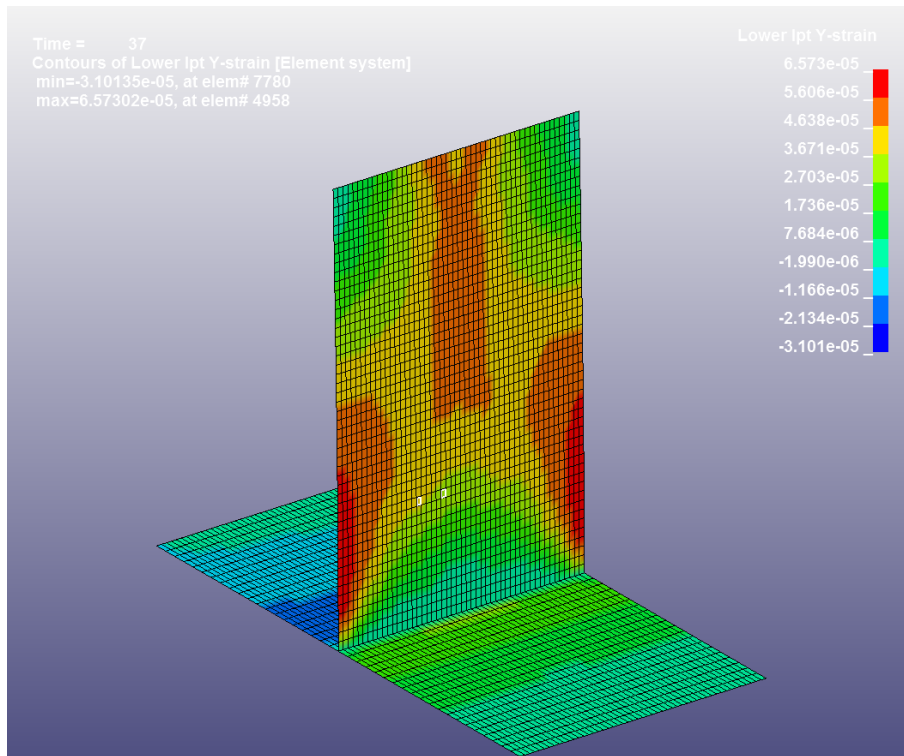

Figure 11 - FEA, Maximum Strain, Load Case A2
(Fish not shown for clarity, "strain gauge" element locations highlighted in white)

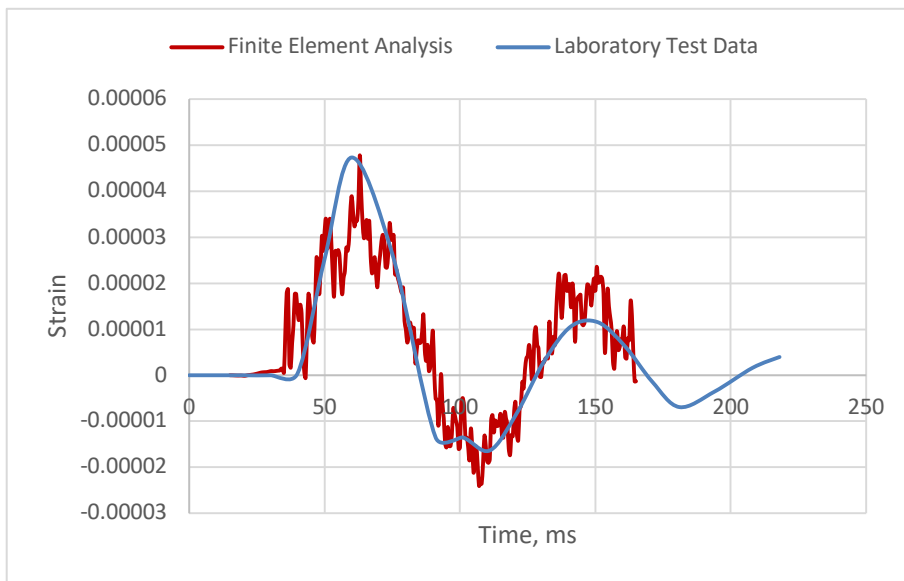

Figure 12 - Actual vs Simulated Striped Bass Impact on Plate at 0.4m/s, Load Case A3

23 April 2018

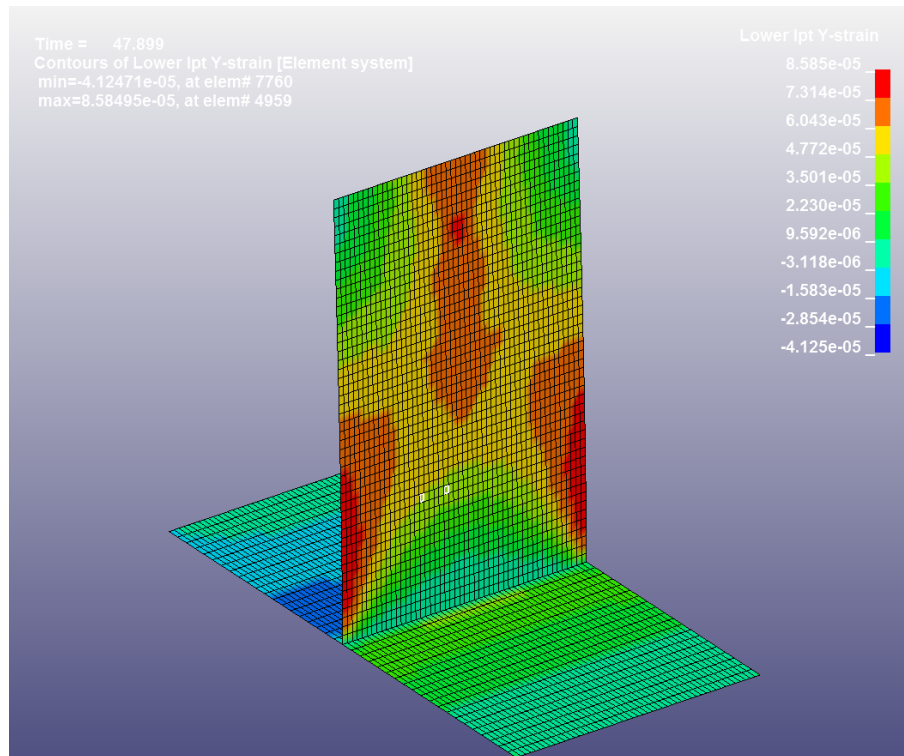

Figure 13 - FEA, Maximum Strain, Load Case A3
(Fish not shown for clarity, "strain gauge" element locations highlighted in white)

7.2.2 Discussion

The laboratory test data compares favourably with the corresponding finite element simulation of the laboratory setup. The peak level of strain during impact is similar at each velocity, albeit with slightly higher strains being experienced in the finite element analysis. This is likely due to the simulated impact being an idealized model, with the fish perfectly aligned when impacting the plate.

In addition, the signature of the impact is also comparable between the laboratory tests and finite element analysis with the plate vibrating at a similar wavelengths post-impact.

23 April 2018

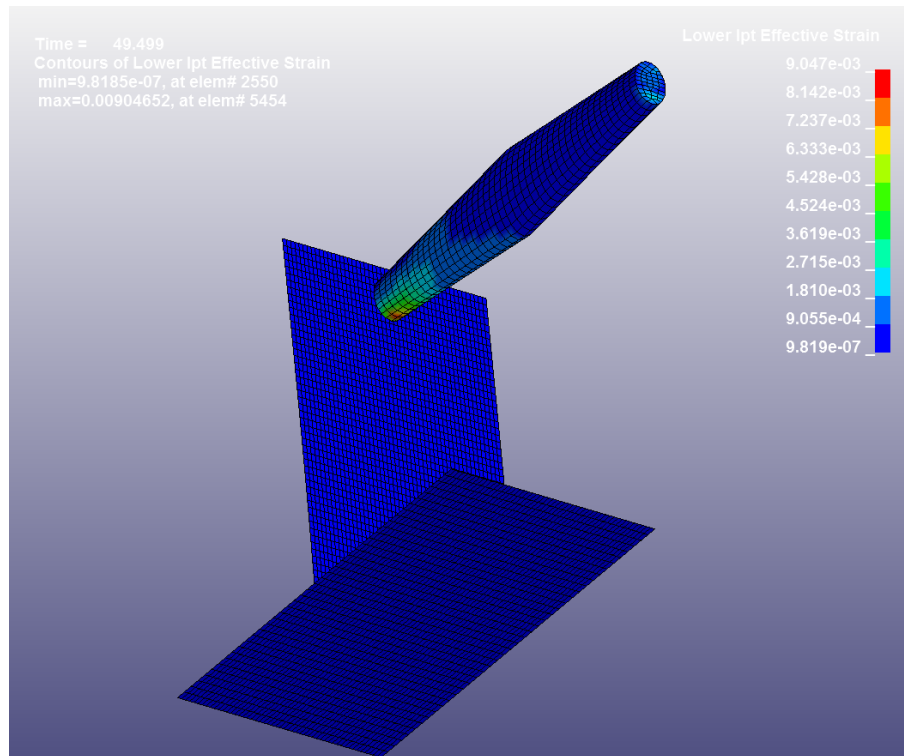

Figure 14 - FEA, Maximum Strain in Fish, Load Case A3
(Strain in aluminum plates not shown for clarity)

Also of note is that the location of the strain gauges does not correspond with the location of the highest level of strain encountered in the plate, with maximum strains of approximately twice the recorded strain occurring at the lower sides of the plate and at the impact location. The highest strains in the fish occurred in load case A3 (the highest flow rate), however the maximum strain of approximately 0.009 did not trigger any element failure which corresponds with no observation of any fish damage due to impacts during the laboratory tests.

The results of this comparison provided justification for the continued use of the finite element model of the fish in the subsequent fish and blade impact simulations.

23 April 2018

7.3 Fish Mortality Due to Turbine Blade Impact

The results of the Turbine Blade impact finite element analysis for each load case are shown in the following sections.

7.3.1 Results

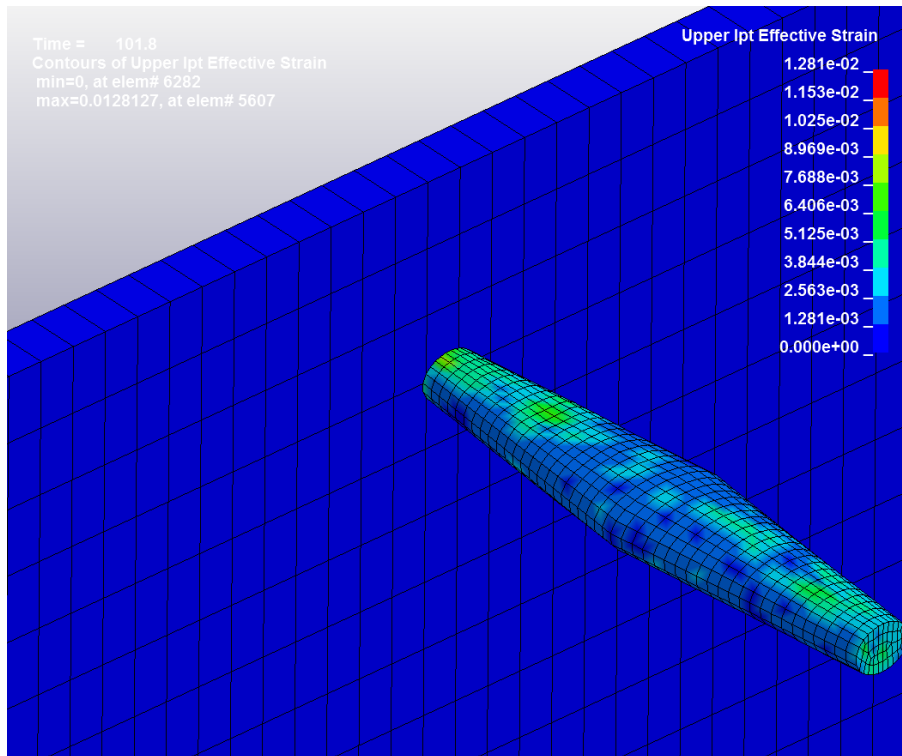

Figure 15 - FEA, Maximum Strain, Load Case B1

23 April 2018

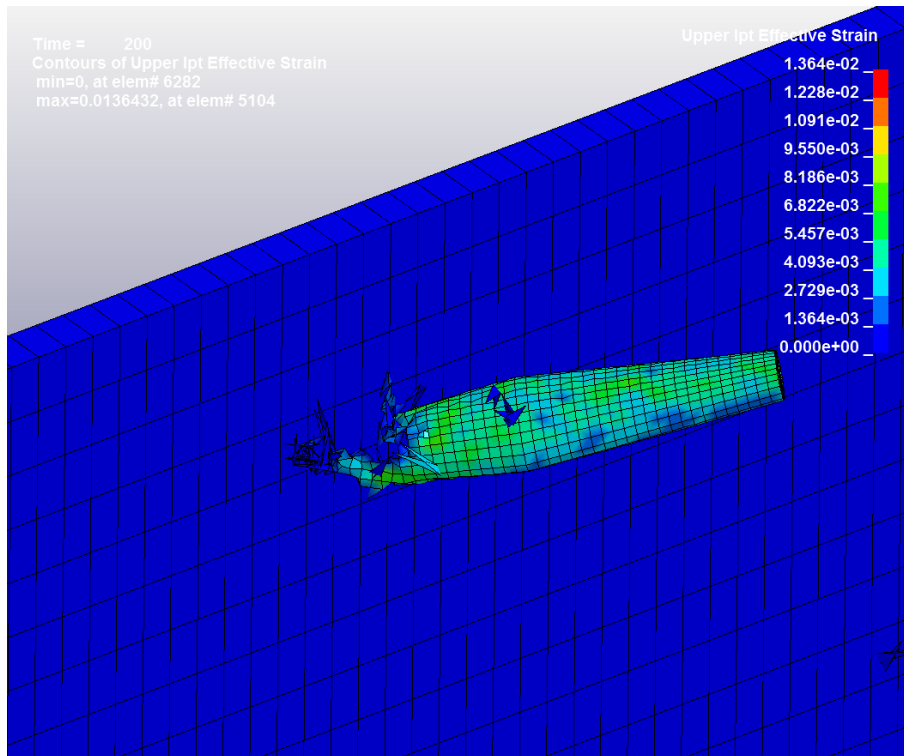

Figure 16 - FEA, Post-impact Strain and Element Deletion, Load Case B2

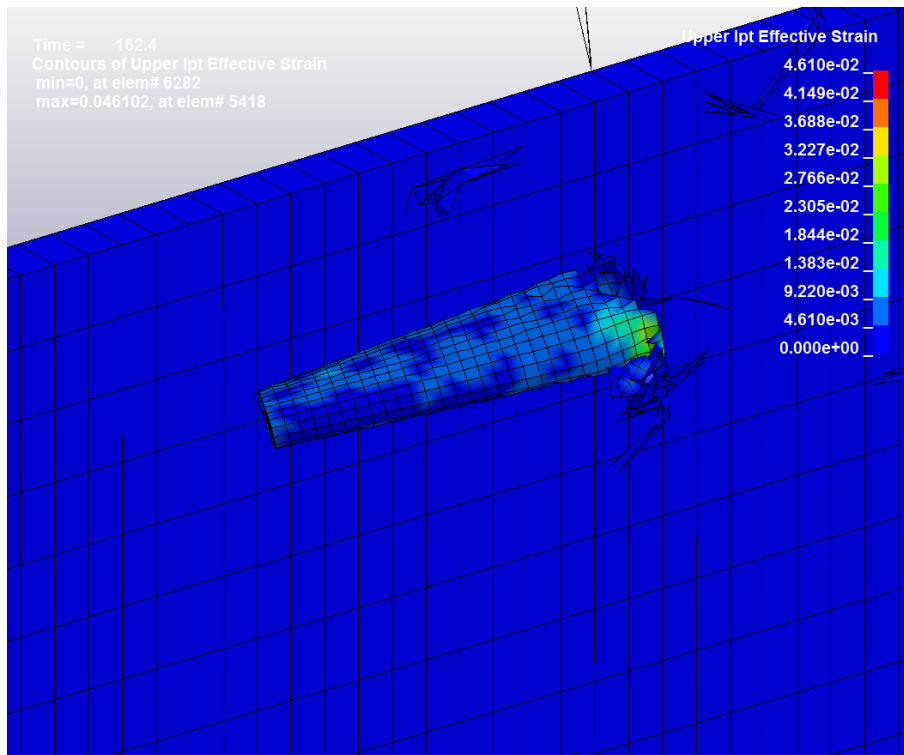

Figure 17 - FEA, Post-impact Strain and Element Deletion, Load Case B3

23 April 2018

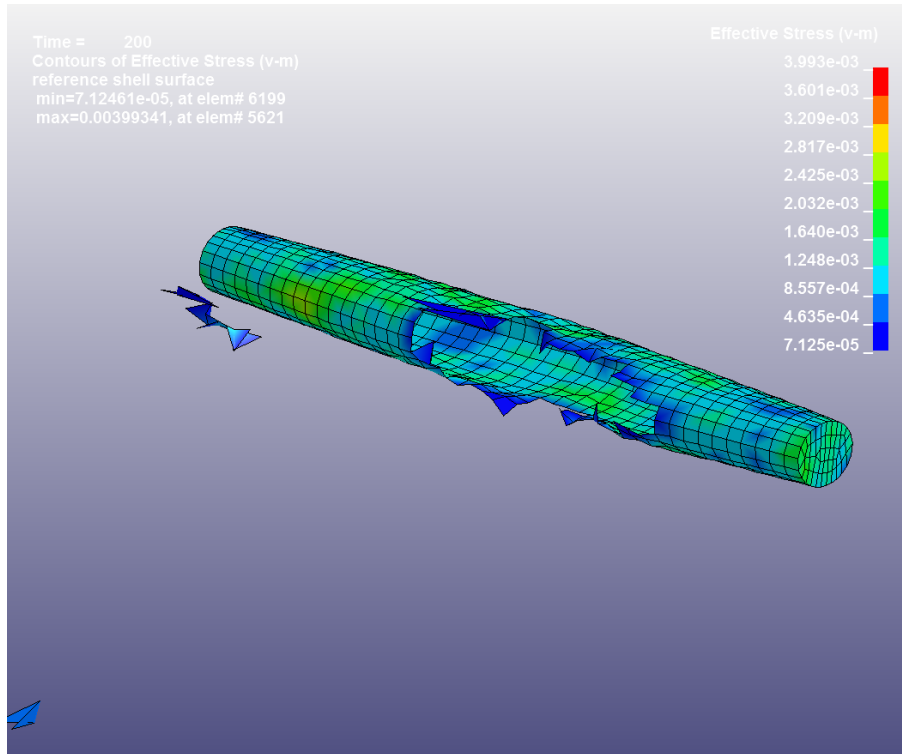

Figure 18 - FEA, Post-impact Strain and Element Deletion, Load Case C1
(Blade and Internal fish flesh elements not shown for clarity)

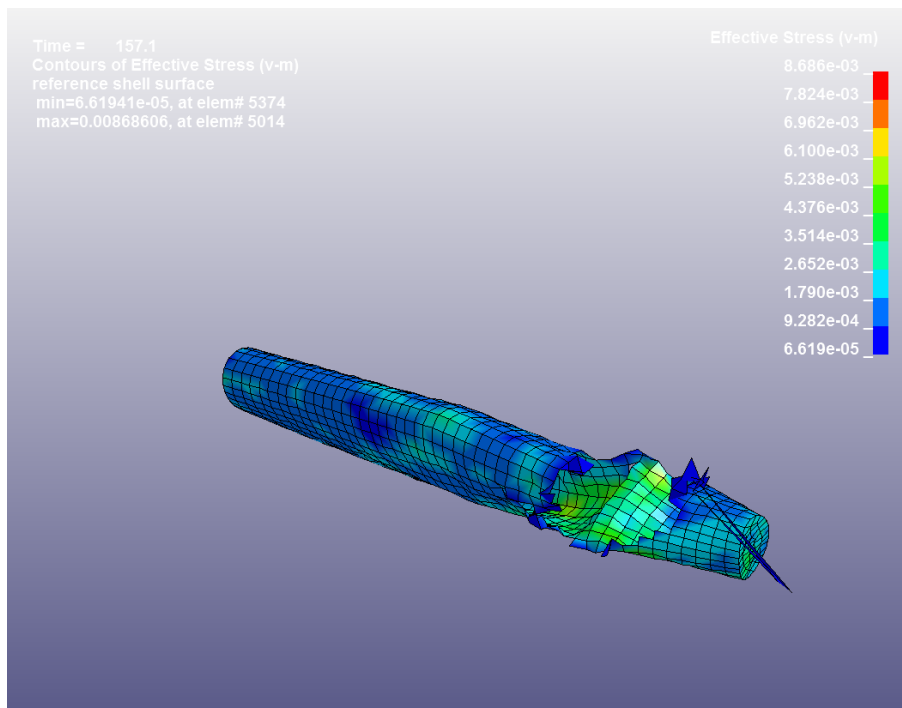

Figure 19 - FEA, Post-impact Strain and Element Deletion, Load Case C2
(Blade and Internal fish flesh elements not shown for clarity)

23 April 2018

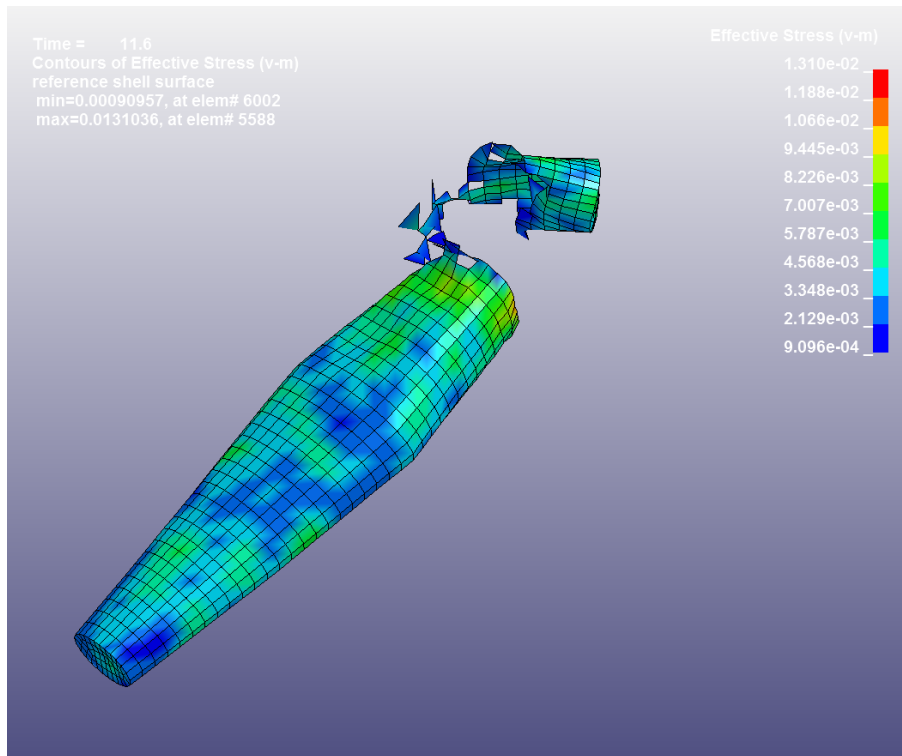

Figure 20 - FEA, Post-impact Strain and Element Deletion, Load Case C3
(Blade and Internal fish flesh elements not shown for clarity)

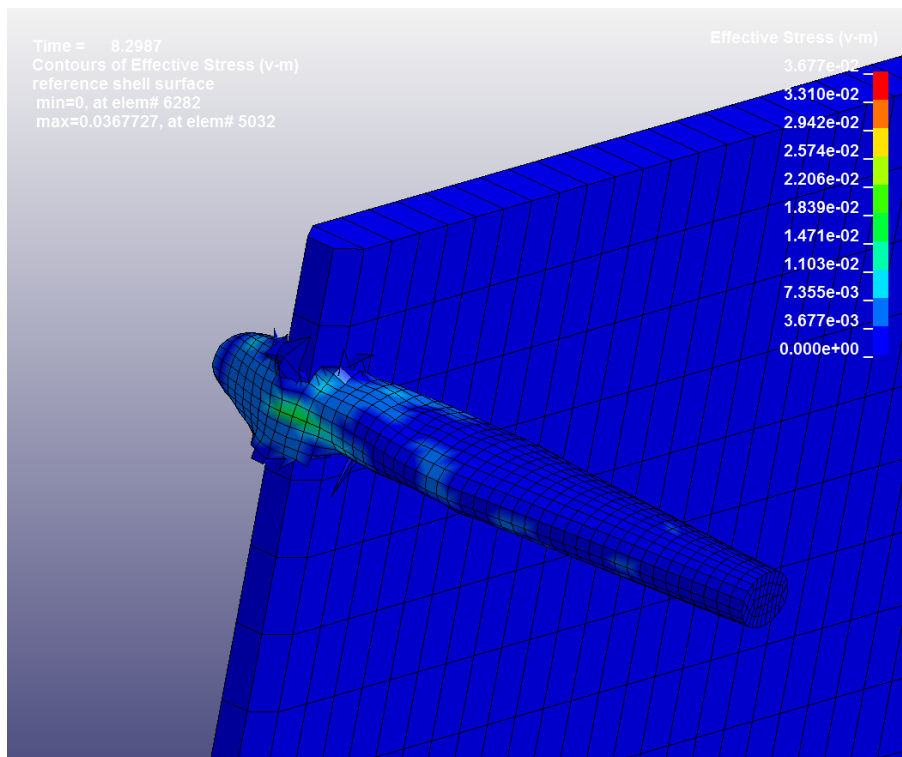

Figure 21 - FEA, Mid-impact Strain and Element Deletion, Load Case C3

23 April 2018

7.3.2 Discussion

The failure criteria included in the material definition for the finite element analysis, particularly for the fish scales, are based on previous research data on the mechanical properties of fish and therefore should provide a good indication of whether the structural integrity of the fish scales will be comprised during an impact event. If significant quantities of the fish scale elements fail during the analysis, it is assumed that the fish will be severely injured.

The velocity of the fish impacting the blade at 1 m/s was the only load case where no element deletion occurred and therefore no failure criteria were reached during the analysis. The peak strain of approximately 0.013 was significantly less than the fish skin failure criteria of 0.1.

Significant element deletion occurred during the load case B2 with several elements exceeding failure criteria in the “head” area of the fish in the region local to the impact area.

Load case B3 again shows large quantities of elements being deleted due to failure criteria being exceeded with damage extending all the way from the “head” to an area near the mid-body of the fish.

The results of the slowest rotational velocity impact corresponding to load case C1 (2 rpm), show significant element deletion around the area of impact which in this case is further towards the mid-body of the fish than other load cases. Load case C2 shows only a slightly greater level of element deletion at a higher rotational velocity four times greater than C1, however the impact location is further towards the “head” and the element deletion area extends further around the circumference of the fish.

Load case C3 corresponds to a blade rotation of 24 rpm which is in the range of the highest speeds that may be encountered during turbine operation (Carlson, et al. 2014). Not surprisingly based on the results of the previous load cases the fish model is separated into two pieces by the impact of the blade. The pattern of element deletion, however, is more localized to the impact area as the strain is not able to be transferred to the surrounding areas due to the severity and brevity of the impact.

It is important to note though that these results of course assumes the fish is not able to maneuver out of the way of the blade or swim at a different relative speed to the turbine blade, which should be considered when viewing the results of this study.

It is difficult to ascertain the level of injury for the fish when the failure criteria is not met, however the analyses show significant failure of the finite elements in all load cases apart from B1 at the slowest impact velocity. Based on the significant “damage” shown in the

23 April 2018

results of these analyses there are perhaps no or at least very few situations where an operating turbine blade impacting a fish will not result in the fish's mortality. In situations where the turbine is not operating and the fish impacts the blade, unless the flow is at a very low speed, then this will also result in the fish's mortality.

8 Recommendations

The results of this study show that it is possible to accurately simulate fish impacts with tidal turbine blades and provide an indication of fish mortality for such impacts. In addition, the use of strain gauges to monitor fish impacts is possible but data may be obscured by flow "noise" at higher flow rates. Nevertheless, this study would benefit from the following additional work:

1. Testing of strain gauge measurement of impact events in operational flow conditions 2m/s to 5m/s,
2. Investigation into technology and techniques that may allow filtering or extraction of impact data from flow "noise",
3. Investigation into whether the strain gauge data "signature" of a fish impact can be used to distinguish the impact of a fish from another object (such as debris etc.),
4. Refinement of finite element techniques to analyze the effects of blade impacts on larger biological objects, such as marine mammals,
5. Investigate the use of finite element analysis to study the effects of impacts on the structural integrity of the turbine itself.

23 April 2018

9 References

- Carlson, TJ, M. Gear, AE Copping, R. Jepsen, M. Halvorsen, and K. Metzinger. 2014. "Assessment of Strike of Adult Killer Whales by an OpenHydro Tidal Turbine Blade."
- Dong, R. G. 1978. "Effective Mass and Damping of Submerged Structures."
- Government of Canada. n.d. *Species at Risk Public Registry*. <http://www.sararegistry.gc.ca>.
- Mesa-Munera, E., J. Ramirez-Salazar, P. Boulanger, and J. Branch. 2012. "Inverse-FEM Characterization of a Brain Tissue Phantom to Simulate Compression and Indentation."
- Szewciw, L., and F. Barthelat. 2016. "Mechanical properties of striped bass fish skin: Evidence of an extendon function of the stratum compactum."
- Vernerey, F., K. Musiket, and F. Barthelat. 2013. "Mechanics of fish skin: A computational approach for bio-inspired flexible composites."
- Zhu, D., C. Fuentes-Ortega, R. Motamedi, L. Szewciw, F. Verperey, and F. Barthelat. 2012. "Structure and mechanical performance of a "modern" fish scale."