



COMMISSION OF THE
EUROPEAN COMMUNITIES



Equitable Testing and Evaluation of Marine Energy Extraction Devices in terms of Performance, Cost and Environmental Impact

Grant agreement number: 213380

EquiMar

Deliverable D7.2.1 Procedures for Economic Evaluation

DRAFT

Grant Agreement number: 213380

Project acronym: EQUIMAR

Project title: Equitable Testing and Evaluation of Marine Energy Extraction Devices in terms of Performance, Cost and Environmental Impact

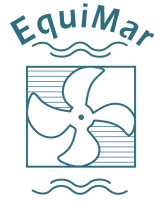

Deliverable D7.2.1

Procedures for Economic Evaluation

Tom Davey and Gareth P. Harrison

University of Edinburgh, UK

Tim Stallard

University of Manchester, UK

July 2009

Summary

This report examines the key considerations in assessing the economics of marine energy technologies. It briefly examines existing practices and criticisms of them, in particular, the need to better capture the uncertainties and risks associated with the technologies themselves and other factors. It explores the key capital and operational costs as well as the revenue earned by schemes and identifies where the uncertainties lie. It sets out a largely generic procedure to economically evaluate marine energy technologies and how associated uncertainties may be handled.



The University of Manchester



CONTENTS

1	ASSESSING MARINE ENERGY ECONOMICS	1—1
2	CAPITAL EXPENDITURE (CAPEX)	2—2
2.1	CAPEX COMPONENTS	2—2
2.1.1	<i>MEC Devices</i>	2—2
2.1.2	<i>Site Infrastructure</i>	2—2
2.1.3	<i>Decommissioning</i>	2—2
2.2	CAPEX INPUTS	2—3
3	OPERATIONAL EXPENDITURE (OPEX)	3—3
3.1	OPEX COMPONENTS	3—3
3.1.1	<i>MEC Planned Maintenance</i>	3—4
3.1.2	<i>MEC Unplanned Maintenance</i>	3—4
3.2	OPEX INPUTS	3—4
3.2.1	<i>Maintenance and Repair Strategy</i>	3—4
3.2.2	<i>Device Availability</i>	3—5
4	REVENUE	4—5
4.1	REVENUE COMPONENTS	4—5
4.1.1	<i>Resource, Device-Performance and Predictability</i>	4—5
4.1.2	<i>Wave Energy Resource Predictability and Uncertainty</i>	4—6
4.1.3	<i>Tidal Stream Resource Predictability and Uncertainty</i>	4—7
4.1.4	<i>Electricity Price</i>	4—7
4.2	REVENUE INPUTS	4—7
5	THE PROPOSED APPROACH	5—8
5.1	APPLICATION OF THE COST MODEL	5—11
5.2	CONCLUDING REMARKS	5—11
6	REFERENCES	6—12

1 ASSESSING MARINE ENERGY ECONOMICS

There are a wide variety of users of economic information on energy generation technologies: policymakers, analysts, technology developers, equity investors in specific technologies or projects (e.g., venture capitalists), utilities, banks and other lenders. Each has their own information requirements and criteria for decision-making. For example, lenders typically look at the security of repayments through examination of coverage ratios; venture capitalists look at growth in value of the technology developer itself and are interested in the quality of the human capital; while policymakers may be looking to support promising technologies. With newer technologies like wave and tidal energy, much is made of their costs being higher than established generating options. However, it is abundantly clear from the literature (e.g., Gross *et al.*, 2007) and discussions with stakeholders (e.g., Electricité de France, 2009) that while cost is an important factor for decision making it is not the only consideration.

Cost information is used by marine energy technology developers as a metric for measuring design improvements towards full production levels. Typically cost is measured by cost of energy (or levelised cost) which aims to capture the lifetime costs of a generator and allocate those costs to the lifetime electrical output with both costs and output discounted to present value. It is expressed in €cents/kWh. The approach was developed for regulated monopoly utilities to provide a first estimate of the relative costs of plant (Gross *et al.*, 2009); it is still used in a similar manner by liberalised utilities (Electricité de France, 2009). It is most widely used by policymakers to indicate the relative merits of different generating technologies as well as in identifying and justifying the need for subsidy for developing technologies (Gross *et al.*, 2009). The major limitation of this measure is that it neglects the entire revenue side of the investment decision.

Real investment decisions cover both costs and revenues, assessing them on the basis of discounted cash flows. Such present value methods account for the timing as well as the magnitude of costs and revenues. The basis of these methods is the idea that a lower value – a greater discount – should be placed on cash flows in the future than on those occurring today as there is a risk that future cash flows may not occur. Net present value (NPV) is the sum of all the costs and revenues over the lifetime of the investment discounted to the present day. A project with an NPV greater than zero has a return exceeding the minimum expected rate and would be regarded as beneficial to undertake. For a generation project the NPV can be expressed in €/kW installed. For high capital cost, low fuel cost technologies such as wave and tidal energy, the cost of energy is very sensitive to variations in discount rates. Internal rate of return (IRR) is related to NPV as it is the discount rate at which the NPV is zero (i.e., where the present value of all future expenditures balances the present value of all future revenues). In effect the IRR measures the cost of capital that the project could support and is often compared to a hurdle (minimum) rate. Care must be taken with IRR as it implicitly assumes that returns can be invested at the same rate and that changes in net cash flows can lead to multiple project IRRs.

Often the only information communicating economic viability is the rate of return or the unit cost. However, this implicitly hides the critical role of risk in economic appraisal. While discounting methods like cost of energy, NPV and IRR attempt to encapsulate risk through the discount rate it is in a non-specific way. Discount rate is typically the company's weighted average cost of capital which reflects the differing required rates of return for equity (shares) and debt as well as the balance of debt to equity. This does not fully capture the risks affecting specific projects or technologies, particularly for new projects whose risk structure differs from existing activities. A higher discount rate is often imposed in such cases to allow for 'technology risk' (Electricité de France, 2009). The premium can be substantial with Entec (2006) suggesting that for UK marine energy a discount rate of 15% would apply to less developed technologies to represent the greater uncertainty associated with both design and cost estimation while an 8% rate would apply to more established technologies.

It is common when comparing different technologies that the same discount rate is applied across the board (i.e. to all cash flows) (IEA, 2005). However, this implicitly suggests that the risk profile of (say) a wave energy converter is the same as that of a gas-fired power station. Common sense suggests this is not true since one has a largely predictable cost stream whereas the other is exposed to volatile wholesale gas prices. Specification of discount rates on the basis of exposure to specific risk factors has been suggested as a means of properly levelling the playing field (Awerbuch, 2003). This involves applying different risk-adjusted discount rates to different cost or revenue streams or classes of streams, e.g., a higher discount rate would be used for cash flow dependent on fuel prices than for long-term fixed value contracts). Identification of the risk premium for each risk factor is a significant challenge and the 'technology risk' premium that applies a single risk-adjusted discount rate is a much simplified version of this.

Techniques applied in financial markets may be helpful in tackling such difficulties. The Capital Asset Pricing Model (CAPM), widely used to translate the required rate of return (i.e. discount rate) to the risk of specific cash flows has also been proposed (Awerbuch, 2003). Normal practice sees this applied to the returns from specific company stocks by defining their correlation with the stock market as a whole. For an emerging sector like marine energy with few (if any) companies offering traded stock, there is limited data to enable such analysis. Boud and Thorpe (2003) assessed the risk parameter (Beta) for sectors that are 'similar' to marine energy and found that no sector-level risk adjustment is required. A parallel approach applying the CAPM to the variance of individual cash-flows rather than stock returns (Harrison *et al.*, 2003) may be a more appropriate way of assessing specific marine energy devices at different stages of development. To do this requires a much greater understanding of the risk and uncertainty associated with individual technologies – effectively a device specific breakdown of the 'technology risk'.

The main uncertainties for marine energy can be grouped into capital costs, operating costs and revenues. This report sets out where uncertainty can arise and explores how this can be incorporated generically within economic appraisal.

2 CAPITAL EXPENDITURE (CAPEX)

2.1 CAPEX COMPONENTS

The capital costs of marine energy scheme may be divided into four broad categories

- Marine energy converter (MEC) itself
- Mooring / Station-keeping
- Cabling (inter-array and site to shore)
- Site to grid transmission (not considered in EquiMar)

Much of the analysis of these cost components is complicated by their technology-specific nature. It is also the case that much of the information is commercially sensitive and is not therefore in the public domain. It is possible, however, to examine the broad cost inputs and their associated uncertainties.

2.1.1 MEC Devices

The capital cost of a MEC device is determined by its component (e.g. structure) and functional (e.g. production) costs and these elements can be further subdivided into cost areas such as power take-off and structure. Elements are specific to the device technology and are dependent on the detailed design of the device. Commercial sensitivity and intellectual property considerations effectively prevent fully independent appraisal of the capital costs associated with a particular device. While this type of engineering cost approach would be useful for those wishing to conduct a cross comparison of a wide range of MEC device types and concepts, it may not be significant in the assessment of a planned deployment. In these cases costs will be supplied by the device suppliers. The evolution of future costs, and their associated uncertainties, is likely to be a major topic of interest.

Identification of the major cost factors associated with the device may allow for future design and scale evolutions to be assessed. For example, prices of individual components and materials will potentially remain fairly constant while production costs (per device) reduce as the technology and manufacturing techniques mature. As the device design becomes mature the cost risk that remains will largely be due to fluctuations in materials and production prices.

The station keeping technology, e.g., mooring of MEC devices tend to be device- (or device class-) specific and it may therefore be sensible to combine the cost of the station keeping hardware with the cost of the MEC device itself. Elements of these costs, however, will be site dependent: water depth, the nature of the sea bed and prevailing weather conditions will all affect the costs associated with the station keeping technology. Similar risk profiles would be expected to the devices themselves.

2.1.2 Site Infrastructure

The civil infrastructure required for an offshore marine energy scheme will generally be associated with station keeping. As discussed above, these costs will be highly device specific. Floating MEC devices require a mooring system while fixed devices will have some form of anchoring system (e.g. pilings or gravity base). The choice of station keeping mechanism may also affect the operational and maintenance aspects of the device (as discussed below).

A number of design solutions are available for the mooring of floating MEC devices. A mooring system must provide adequate station keeping without impeding the power conversion capability of the device. The level of compliance desired will be determined by the power conversion characteristics of the device. The station keeping footprint will be determined by practical concerns regarding acceptable excursions (e.g. device interference in an array) as well as possible limitations on loads and movement of the electrical transmission cable. Concerns regarding survivability under extreme environmental conditions must also be factored into the choice of mooring system.

The plant and machinery required for installation will be dependent on the type and scale of the technology, as well as the installation environment. Examples of civil infrastructure include piling, gravity bases and shore-based structures. Early installations have noted that the availability of suitable installation vessels is vital for cost effectiveness. Some of the vessels used are specially designed or adapted for the technology (e.g., OpenHydro) while others are standard types. In the latter case, these may also be involved in servicing offshore oil and gas infrastructure, and particularly when oil and gas prices are high, there tends to be competition for the vessels. Restrictions on the sea states within which vessels can safely operate mean that during good weather, the availability of suitable vessels can be heavily restricted or hire rates very high.

2.1.3 Decommissioning

Device decommissioning at the end of the project life may take many forms. Options include retrieval to shore for scrapping or disposal at sea (e.g. in the form of an artificial reef). Depending on the disposal strategy the costs associated with decommissioning may be offset by the scrap value of the device. The multi-decade design life of MECs and, the use of discounting, are such that the costs of decommissioning tend to be relatively modest when viewed from the outset. Depending on the significance, funding the decommissioning process can be from ongoing revenues, an endowment fund built up over the lifetime or as is proposed in the US for offshore wind, via an upfront decommissioning bond. Each method has its own inherent risk profile.

2.2 CAPEX INPUTS

Figure 1 shows a flowchart for calculating CAPEX that includes the major contributors to capital cost. Many of the costs will vary with the scale of deployment and further work within Equimar will consider this.

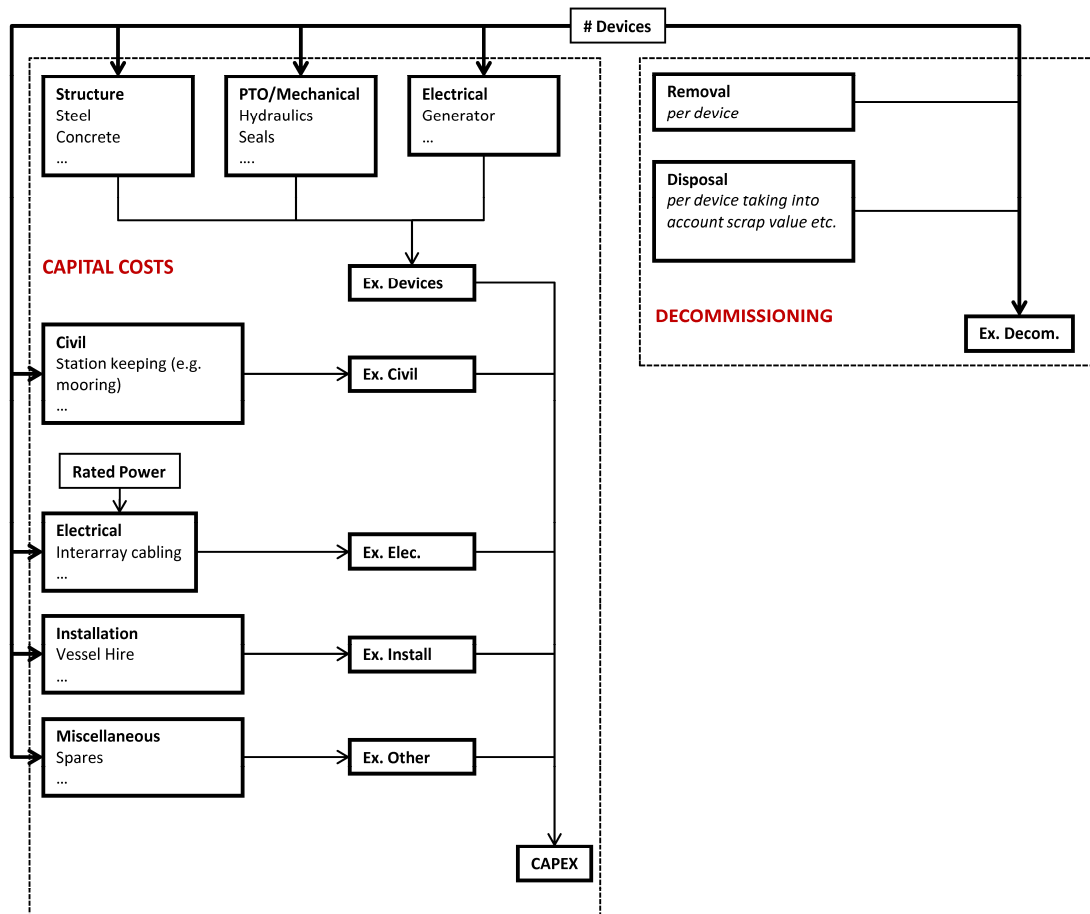

Figure 1 CAPEX Calculation Flowchart (including end of life costs)

3 OPERATIONAL EXPENDITURE (OPEX)

3.1 OPEX COMPONENTS

The annual operational expenditure (OPEX) for a MEC scheme is, in the absence of fuel costs, dictated primarily by the maintenance and repair requirements. The maintenance schedule and reliability will also influence the availability of the device(s), and therefore the revenue earned. The cost factors making up the OPEX are specific to the type of technology (e.g. offshore tidal turbine versus coastal wave device) complicating the process of producing a generic cost procedure. In order to clarify the cost streams the analysis of the OPEX has been divided into two broad categories: planned maintenance and unplanned maintenance (i.e. repair). There may be significant overlap between these two categories, but the distinction is important as it allows a more logical appraisal for a variety of maintenance and repair strategies. This approach also gives a direct output of the expected Availability Factor.

The reliability of a technology affects device availability, and therefore the volume of energy produced. The learning process involved in determining the reliability of the device follows the same broad process as determining device performance. The reliability of the device may firstly be assessed at the design stage through analysis of the constituent components. In many cases the components may be based on established technology or bought “off the shelf”. In these cases detailed reliability information may be available, although this may need to be reappraised if the technology has not been previously employed in the marine environment. The reliability of more novel technologies is likely to be more uncertain. Trial deployments play a large part in assessing the device reliability, although these deployments are unlikely to be representative of the lifespan of a commercial deployment. Experience in the oil and gas sector may be used to inform reliability estimates in the marine environment.

Reliability is clearly device specific and will be estimated through analysis at the design stage and through data obtained during sea trials. The uncertainty associated with the reliability data will reduce as the technology matures. It is also to be expected that reliability will improve with continued operational experience and design iterations.

The influence of reliability on availability will be site and technology dependent. The site accessibility will determine the time to repair the device. Site accessibility is determined by geographic factors (e.g., distance from port) as well as the marine climate. The device type will determine factors such as the type of vessel required, as well as the wave/current climate in which a repair, or recovery, may be made.

3.1.1 MEC Planned Maintenance

Planned maintenance costs are defined as those costs involved with servicing the devices in the MEC scheme to attain the design power output. This includes elements such as vessel costs, labour and consumable components. There are clearly a number of maintenance schemes available, including service-on-site and return-to-shore options. The economic evaluation should include methods of comparing these options as well as the influence on the availability factor.

The planned maintenance of MEC devices cannot necessarily be entirely separated from the repair costs. Work conducted on failed devices is unlikely to be carried out entirely independently of scheduled servicing. For example, a decision may be made to postpone repair of a device until visited (or retrieved) for scheduled maintenance. This will be the case where a device has been designed with redundant systems or can operate sub-optimally until the scheduled maintenance.

3.1.2 MEC Unplanned Maintenance

Costs associated with the repair of MEC devices carry many elements of uncertainty, particularly with early stage technology devices. The mean time to failure is dependent on many factors, including the failure mode and the type of environment. These elements, combined with repair strategy, will contribute towards the device Availability Factor.

The mean failure frequency must be estimated based upon an engineering appraisal of the device design. In some cases failure distributions may be available for individual components, particularly if they are established technology bought “off the shelf”. Care must be taken, however, if these components are being deployed in an environment significantly different from their usual operating conditions. Data from prototypes and sea trials should be incorporated into failure rate estimation wherever possible.

The cost of vessels to carry out the maintenance will be a major factor in OPEX but it is probably more uncertain for unplanned maintenance since the vessel has not been specifically scheduled to be available and failures are more likely whilst access may be difficult.

3.2 OPEX INPUTS

The elements describing the OPEX and Availability Factor are outlined in Figure 2. The calculation process is divided into planned and unplanned maintenance elements with the output of these components used to estimate the Availability Factor.

3.2.1 Maintenance and Repair Strategy

The calculation procedure is complicated by the variety of maintenance and repair strategies available. The simplest approach is to assume no link between the planned maintenance (servicing) and unplanned maintenance (repair). In this case there will be a certain frequency of servicing “operations” required for each device. The procedure outlined in Figure 2 assigns a cost for accessing the device and a cost for the maintenance operation itself. This approach also allows for the downtime associated with maintenance operations to be fed into the calculation of the Availability Factor.

The costs directly incurred in the servicing of both the device and associated infrastructure (moorings, cables etc.) are described on a cost-per-device basis. This includes items such as consumable components, and labour costs directly attributable to the servicing of the device. If the devices are retrieved to the shore for maintenance then the costs associated with this (excluding the vessel cost) are assigned here.

The repair strategy for devices is potentially more complex due to the significant uncertainty associated with predicting reliability for early stage technology. The costs associated with repair are calculated using a similar methodology to the planned maintenance costs. Costs are assigned to the access of the device (through vessel rates and required duration of access) and to the repair itself. The frequency of repair visits (or device retrieval operations) is determined by the failure rate of the device. The simplest scenario in terms of repair strategies is that the device is repaired on demand. In this case a Response Time element is included in the analysis, this being the mean expected time that will pass before the repair operation can commence; imposed either by vessel availability or site accessibility. While there may be no direct repair cost associated with the Response Time it will impact on the Availability Factor, and therefore on the collected revenue.

In some circumstances it may be acceptable to treat the planned and unplanned maintenance strategies as independent in order to simplify the modelling procedure. This may include MEC schemes where the planned maintenance intervals are large. In other cases it may be unrealistic to assume that repairs will be undertaken entirely separately to the planned maintenance operations. In this case the access costs (e.g., vessel hire) associated with repair may be assumed to be some proportion of the full rate. For example, if all repairs are conducted alongside planned maintenance operations the access costs may be assumed to be zero. The mean response time should also be adjusted to reflect the repair strategy.

The accessibility of the site is also of concern when assessing the OPEX. Offshore devices will usually only be accessible under particular conditions of the sea-state. For example, there may be a maximum significant wave height or tidal stream velocity (or combination of the two) under which the maintenance and repair work may be safely implemented.

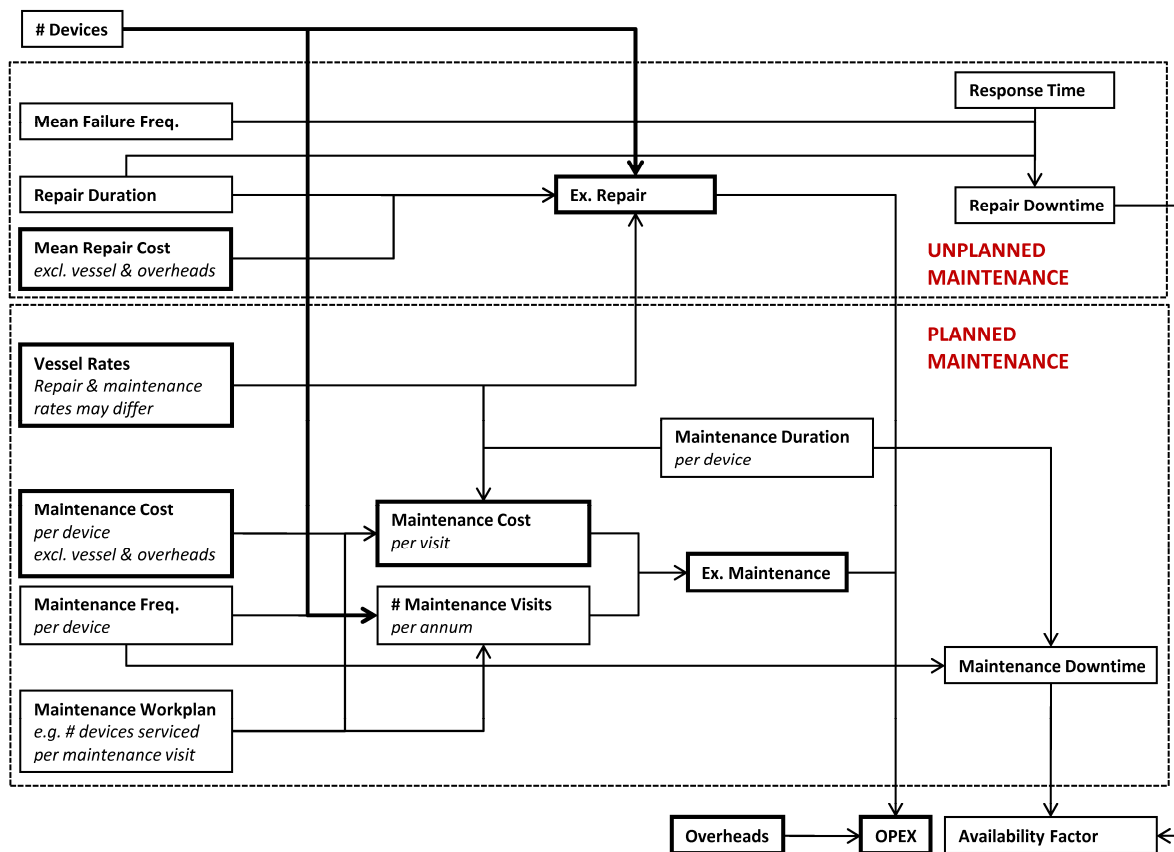

Figure 2 OPEX calculation flowchart

3.2.2 Device Availability

A reason for separating the analysis of planned and unplanned maintenance activities is to allow the Availability Factor of the device to be assessed. An Availability Factor of one indicates the device has no downtime. The downtime associated with differing maintenance operations may vary. It is not necessarily the case that all maintenance operations will require the device to be taken offline. In this case the Maintenance Downtime (Figure 2) may be expressed as a proportion of the maintenance duration.

The Repair Downtime is calculated as a function of the response time, the transit time and the repair duration. The repair downtime and maintenance duration may be combined to calculate the overall Availability Factor. This figure may then be incorporated in calculation of the expected revenue.

4 REVENUE

4.1 REVENUE COMPONENTS

4.1.1 Resource, Device-Performance and Predictability

The power output from a MEC is dependent both on the characteristics of the installation site (the resource) and the device itself. These elements will both have an associated uncertainty.

The prediction of the resource at the site will have an associated uncertainty due to the limitations of the modelling methods (e.g. numerical/statistical modelling) and the measurement programme (e.g. wave buoy deployment). Methods for quantifying these uncertainties are covered within the EquiMar project under *Work-Package 2: Resource Assessment*. The uncertainty associated with the resource is likely to reduce over the lifetime of the scheme as the site becomes better characterised through operational experience. There will, however, always be an underlying disparity from the baseline resource due to annual variations. This is particularly true for the estimation of the wave resource. It may take many years of measurements to correctly characterise this annual variation. EquiMar WP2 is exploring methods for the quantification of this underlying uncertainty but this aspect is briefly considered for wave and tidal separately in sections 4.1.2 and 4.1.3.

The quantity of energy produced by the device is of particular importance in the renewable energy sector as, in the absence of fuel costs, it solely determines the project revenue. The performance of the device will determine the ability to convert the theoretically available resource to usable energy. The uncertainty associated with device performance will vary with the maturity of the technology. At its earliest stage the device performance will be based upon information gleaned during the design process. This is

highly likely to include assessment using numerical models and/or small-scale tank testing. Guidance relating to this early stage concept appraisal is being investigated under the remit of *Work-Package 3: Concept appraisal and tank testing practises for 1st stage prototype devices*. A commercial MEC deployment will likely require a more robust validation than can be provided with this level of testing. This early stage appraisal does, however, allow the device performance to be assessed for specific environmental conditions (i.e. a particular sea-state or tidal stream) and is therefore a valuable tool for understanding the benefits and risks associated with a particular technology concept.

The stage following early concept appraisal of a device is typically a real-world deployment using either scale or full-size prototype devices. This may take place at a well-validated test site, such as the European Marine Energy Centre (EMEC) in Orkney. The procedures employed in designing and analysing these sea trial deployments should be conducted in such a way that they effectively reduce the uncertainty associated with the device performance. The obvious lack of control over the environmental conditions requires these procedures to be robust and consistent. This is explored in the EquiMar project through *Work-Package 4: Sea trial testing procedures for marine energy extraction devices*.

Information from the sea trials will typically assess the performance of a single device. Commercial schemes may involve the deployment of many devices. The assessment of multi device arrays is examined in *Work-Package 5: Deployment assessment: Performance of multi-megawatt device arrays*. In a commercial deployment the device performance will be used in assessing the suitability of a particular technology for a given site. This guidance is included in the remit of WP5.

If electricity production between different sites is to be compared, some form of functional relationship must be described relating the device power conversion characteristics to the resource. In reality the complexity of this relationship may preclude describing the power production in this manner. In this case a site specific analysis of the device (or device array) performance will be required. This analysis should specify the uncertainty in electricity production, reflecting both the uncertainty in the resource and device performance. If several device types are being compared the uncertainty in the resource parameters should be consistent, while the device performance uncertainty will be larger for early stage devices.

Array interactions may also influence the generating capabilities of a MEC array. This influence may be positive or negative. If these interactions are deemed significant it may be more convenient to describe the electrical output in terms of cumulative output of the array, rather than on a per-device basis. The Maintenance Duration and Response Time should account for the mean expected delay. The associated costs will be dependent on the maintenance and repair strategy and vessel availability.

4.1.2 Wave Energy Resource Predictability and Uncertainty

Prediction of power output from wave energy converters (WECs) must take account of the stochastic nature of the resource. The annual resource will vary, and the baseline resource may be difficult to accurately quantify. The stochastic nature of the resource is typically characterised through use of distributions describing the joint probabilities of the parameters used to characterise the wave resource. The potential wave power available to the device is typically calculated from the significant wave height and the energy period. The joint occurrence frequency of these parameters is typically expressed through a scatter diagram representing the long term statistics of the site.

The summary statistics describing a particular sea state may not fully represent the nature of wave climate. Many spectral shapes may be associated with a particular set of parameters, with a corresponding influence on the available resource. Where more detailed spectral data is available this should be used for a more detailed resource estimate. In cases where a detailed site assessment is to be carried out (buoy deployments etc.) this information should be available to the developer. Many historical oceanographic datasets, however, will provide only limited summary statistics, typically the significant wave height and the mean wave period. In many cases e.g. DTI (2004), the mean wave period was used to infer the energy period through the use of standard spectral shapes; it should be recognised that an element of uncertainty is associated with this process.

The assessment of the wave resource may be broadly defined in two categories. Firstly, the resource may be quantified at a geographic scale in order to identify suitable locations for deployment. An example of this approach may be seen in the *Atlas of UK Marine Energy Resources* (DTI, 2004). Resource assessment carried out at this level will not necessarily account for the local resource variations due to the site bathymetry and coastline. This information is obtained through a more detailed site assessment. This is likely to incorporate the use of numerical models to transform the distant wave climate, combined with measurements. Physical measurements alone are unlikely to capture the long term variations in the wave resource. This detailed site assessment aims to reduce the uncertainty associated with the resource available to a particular device. WP2 is investigating the spatial variation in resource observed at a site. This information will inform predictions on the total available resource obtained from an array of devices, as well as aiding the quantification of uncertainty from a measurement programme.

The elements of wave resource assessment discussed above are relevant to the estimation of the resource available to a WEC, or an array of WECs. The actual energy production will be device specific, and is therefore difficult to discuss in general terms. Several different technology concepts exist, with differing hydrodynamic properties. Device developers will typically produce algorithms and performance matrices to transfer the estimated available resource to an estimated power output. The work of EquiMar work-packages 3, 4 and 5 will provide guidance on device assessment. In cases where the resource information is limited, this should be reflected in the uncertainty associated with the prediction of device performance. For example, summary statistics describing the wave climate may not differentiate between the high frequency and low frequency wave components. Depending on the operational characteristics of the device, this is potentially a significant source of uncertainty when quantifying the usable resource.

4.1.3 Tidal Stream Resource Predictability and Uncertainty

The tidal resource is regarded as relatively predictable when compared to the wave resource although there remains an element of uncertainty in the characterisation of the resource. Prediction of the tidal range and currents may be carried out by harmonic analysis. Each tidal constituent is described by its amplitude, phase lag and angular speed. The greater the number of constituents included in the analysis, the more reliable the tidal prediction will tend to be. Resource characterisation at geographic level may require only a limited number of tidal constituents. The *Atlas of UK Marine Energy Resources* (DTI, 2004) examined average tidal range using 2-4 harmonics, reasoning that inclusion of further components would not influence the result when averaged over a long period. More detailed site assessment will likely require more harmonic components be included in the analysis. Guidance produced by EMEC (2009) suggests a minimum of 20 harmonics be included in site assessment. The harmonics used in tidal resource assessment may be available from sources such as Admiralty Charts and tidal tables. A more site specific analysis will likely require field measurement of the local constituents over a 3-12 month period.

Numerical modelling may be utilised in the estimation of the resource. The level of refinement of the hydrodynamic models will increase depending on the assessment stage. While tidal currents may be predicted with a relatively high degree of accuracy, there remains some uncertainty involved in the assessment of the detailed flow structure. The structure and magnitude of turbulent eddies remains an area of research. Wave-current interaction also introduces an element of uncertainty due to the stochastic nature of the wave climate, and the lack of knowledge describing the interaction processes.

4.1.4 Electricity Price

Price is the other factor in the calculation of revenue and is heavily dependent on the jurisdiction in which the deployment is to be made. Most EU countries have some form of wholesale market, although the actual sectors may be more or less liberalised, state-owned or fully private. Wholesale markets come in many forms and provide a means of trading bulk power. Spot markets set market prices typically on a half-hourly basis, which means that participants in the markets will see revenue vary on this basis. Running alongside the spot markets are forward and futures markets which allow longer term contracts. Wave and tidal developments may be in themselves relatively small and may not participate directly in the wholesale market. They may be directly owned by generating utilities who will manage them within their portfolio or where the owner is an independent power producer the output may be sold to a supplier either on a merchant basis or through a power purchase agreement (PPA). PPAs may specify a fixed price or track average prices on a seasonal basis. It is common in the UK for the prices to be at a discount to average wholesale market prices; in effect the PPA passes some of the producer price risk onto the purchaser in exchange for a lower (semi) guaranteed tariff. Lenders in the UK have been particularly keen on such arrangements to mitigate price risk.

Electricity prices can be very volatile and, depending on the market and the ability of generators to pass-through costs may vary with the price of gas and coal. Prices will tend to reflect demand, with high demand periods during the day and seasonally being more expensive as lower merit plant is brought on line. In modest penetrations wave and tidal schemes will tend to be 'price takers', that is, they cannot set market prices or influence them significantly. When penetrations of variable renewables are higher, there is potential for lower prices during periods of high resource availability and that, where required, some renewable generation may be 'constrained off' – i.e., their output is reduced – to alleviate network constraints. These factors need to be incorporated into the economic appraisal as the market setup necessitates. This will also need to consider the fact that future prices are uncertain in market-based systems and this uncertainty must be reflected in assumptions.

Associated with prices, the appraisal must consider income from subsidy programmes designed to assist developing technologies. In many countries (e.g., Germany) this takes the form of a feed-in tariff (FIT) which pays a defined higher than market rate for renewable production and also eliminates price risk. Others operate a premium price system wherein the electricity market price is supplemented by a defined amount per unit; this partially reduces price risk. In both cases the premium paid reflects how far from market the technology is. Others operate green certificate schemes which set targets for purchasers of electricity to acquire a minimum volume or proportion of electricity from renewable sources. For each unit of electricity purchased they receive a certificate (e.g., Renewable Obligation Certificate or ROC in the UK) which can be redeemed against their target. A penalty is placed for non-compliance with the target which sets a normal minimum price for the certificate. In addition, the UK scheme recycles certificates to those who complied with their target which places an additional premium on the value of the certificate. A market in certificates allows the trading of certificates. In the UK, although there is now differentiation between technologies in terms of the number of ROCs per unit of output, the fact is that the price of the certificates is not fixed and is essentially an additional source of price risk when considering revenue. Again, this variability must be factored into the economic analysis.

4.2 REVENUE INPUTS

The factors involved in calculating the revenue from a MEC scheme are outlined in Figure 3. This calculation procedure assumes that power conversion may be described on a per-device basis. It also assumes that the summary parameters describing the resource may be directly translated into the electrical production from the device. This power conversion process assumes no downtime in production due to maintenance or failure. The electrical production from the MEC array is therefore a function of the resource, the MEC power conversion characteristics and the number of installed devices. Dependent on the device technology, and the analysis methods available, it may not be practical to implement the electrical output from the array in this manner. In this case the electrical production of the array (assuming full availability) must be estimated through some alternative analysis method. This analysis should express the uncertainty estimate of electrical production relating to the uncertainty in the resource estimation and the uncertainty in the performance of the device.

The total expected energy production must take account of downtime due to maintenance and repair operations. This is expressed in terms of the Availability Factor. The calculation of the Availability Factor is described in Section 3.2.2. Accounting for maintenance of the devices in this manner separates the power conversion performance of the device from the maintenance and reliability performance, allowing a more focused sensitivity analysis of the impact on the overall project finances.

Finally the electrical output of the MEC scheme is translated into revenue by the electricity market. In simple terms this may be expressed in terms of the average electricity price. More complex analyses will be dependent on the market structure.

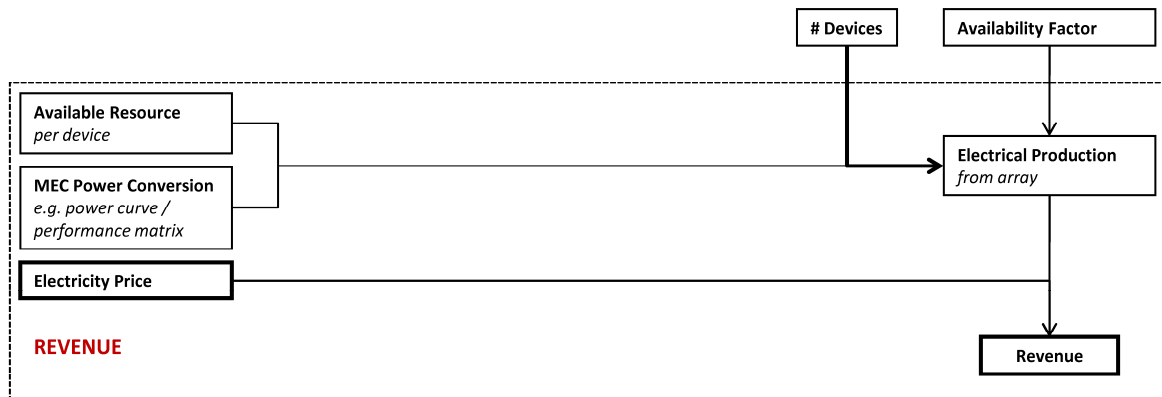

Figure 3 Revenue calculation flowchart

5 THE PROPOSED APPROACH

Earlier sections of the report demonstrate the many sources of uncertainty associated with the economic assessment of marine energy technologies. The proposed approach for economically appraising marine energy technologies is to continue to use well-established and understood methods like NPV, IRR and cost of energy but to allow the effect of the various factors and their uncertainties to be analysed in a consistent and equitable manner for a wide range of technologies and scenarios. Producing a generic analysis methodology is complicated by the very large number of permutations in the cost and revenue factors that may describe a marine energy scheme. This effectively prevents the application of assumptions that may simplify the analysis process.

The calculation of the NPV over the lifetime of the project is summarised by the flowchart illustrated in Figure 4. This procedure calculates the NPV based upon the high-level figures describing capital expenditure (CAPEX, §2); operational expenditure (OPEX, §3); revenue (§4) and decommissioning costs (§2). A more complex approach taking into account the interdependence between the different cost streams is illustrated in Figure 5. These examples calculate the NPV based upon a single discount rate. These procedure flowcharts illustrate the functional relationships involved in the calculation of each cost and revenue stream. Understanding these relationships allows for analysis of the sensitivity of the NPV (or IRR) to uncertainties in the various components and inputs.

While applying this type of sensitivity analysis allows the affect of a given uncertainty from the mean (e.g. $CAPEX \pm \delta CAPEX$) to be examined, it does not describe the full spectrum of NPV values which may be expected. The suggested solution in this case is to analyse the NPV through use of Monte-Carlo simulation techniques in which the uncertain parameters in the model are described stochastically; that is to say that each uncertain element in the model is described in the form of a probability distribution. The distribution used should reflect the underlying processes with, for example, failure data tending to follow a Weibull distribution while many others are likely normally distributed. The resulting NPV, CAPEX, etc. distributions are calculated through multiple iterations of the model. Each iteration involves sampling a single random value from each constituent probability distribution, with the final result representing a possible value of the NPV (or IRR etc.). Thus over the many iterations a distribution of NPV values is constructed. The risks and benefits of a particular scheme can therefore be assessed in a more informed manner than may be achieved through a more simplified sensitivity analysis. A similar approach for costs has been used by Previsic *et al.* (2004).

It is recognised that producing distributions for the uncertain elements may be difficult where information is limited. If, for example, a nascent MEC device only exists at scale prototype scale it may be difficult to extrapolate accurately to full scale the capital costs, reliability, power-conversion performance etc. The distributions used in the model should reflect this uncertainty, e.g., the distribution describing *Mean Failure Frequency* will show a larger variance for a device at the early design stage than the same device later in its development. At very early stage, should probability distributions not be credible some indication of uncertainty should be made; at the most simple end this would be an upper and lower bound for the range of values taken.

The procedure outlined in Figure 5 is intended to provide a common assessment procedure for a range of technologies by decoupling device elements (e.g. reliability) from the elements which are common to all (or most) MEC schemes (e.g. steel prices, database of vessel rates). This is reflected in the complexity of the model. It should be noted, however, that not all elements may be relevant to all MEC schemes. The model as applied in practice may be simplified by the removal or combination of some elements.

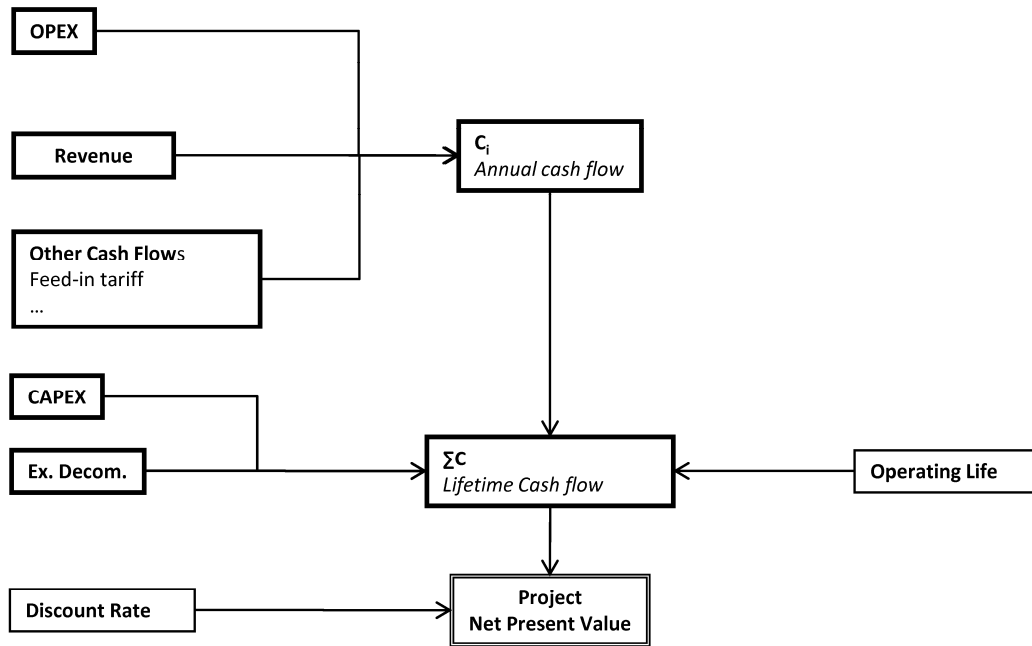

Figure 4 Net Present Value (NPV) calculation flowchart with a single discount rate

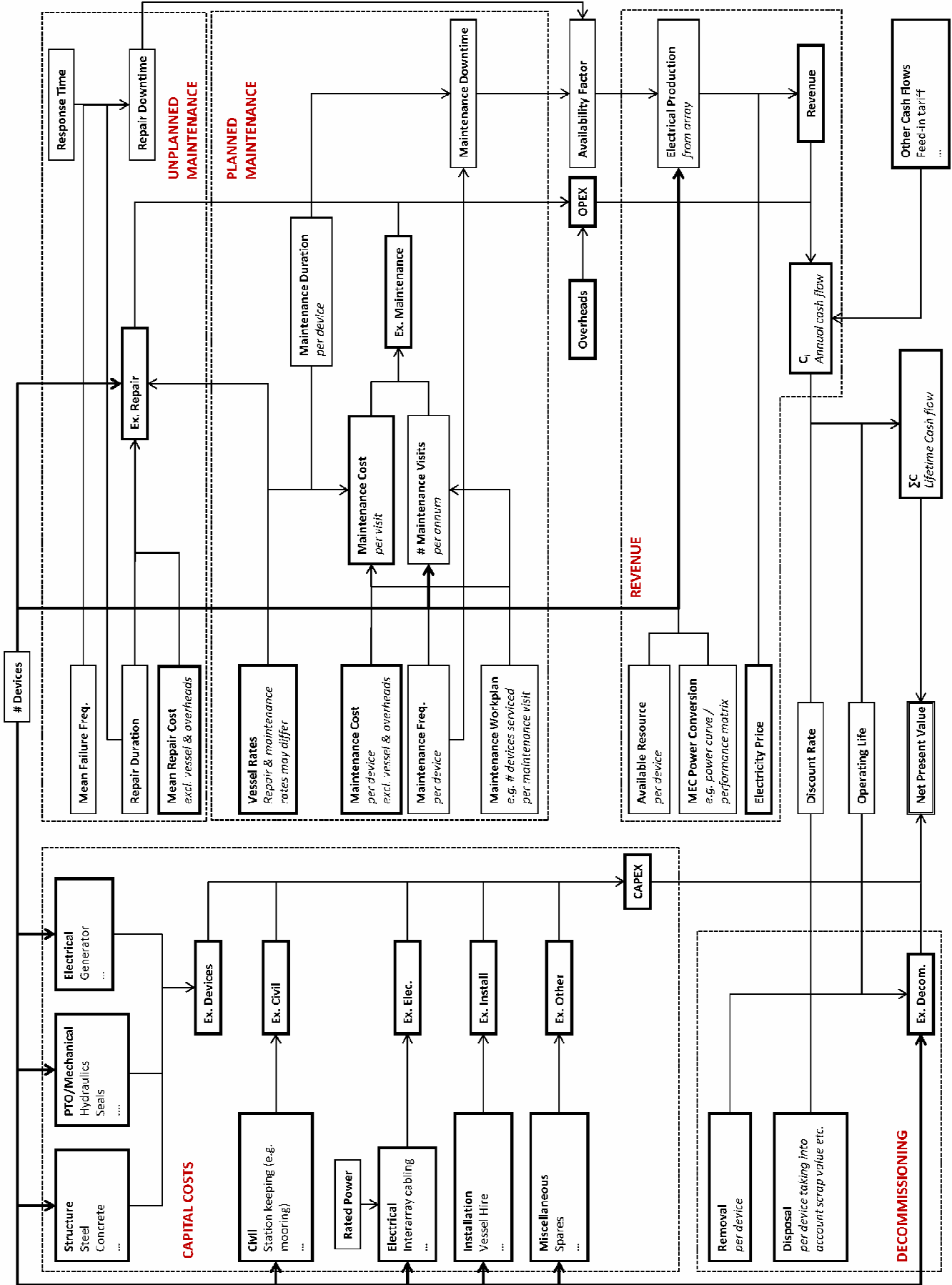

Figure 5 Net Present Value (NPV) calculation process (single discount rate)

5.1 APPLICATION OF THE COST MODEL

The application of the proposed Monte-Carlo analysis method requires the ability to produce sequences of random numbers corresponding to a particular distribution. The mathematics involved tends not to be onerous, but modelling the interactions and functional relationships between the cost elements may be time consuming. A visual programming environment utilising a number of standard “blocks” provides a flexible and intuitive method for the production of cost models. *MATLAB Simulink* is one such programming environment while others include the Palisade @RISK suite for Excel.

Figure 6 illustrates a MATLAB Simulink model of the simple model outlined in Figure 4. A standard input block has been developed to produce the probability distributions describing the uncertain elements. As Simulink is a time-domain simulation programme another block controls the period over which the input is fed into the calculation. In the example shown above the OPEX and Revenue streams are active from the first operational year through to the end of project (L) and in this example decommissioning occurs in the final year. This approach allows fairly complex scenarios to be modelled, such as progressive “ramping-up” to full generation capacity. Finally, the cost streams are combined for calculation of the NPV. In modelling scenarios where multiple discount rates are required the NPV calculation block is applied to each individual cost stream and the outputs summed to produce the project NPV.

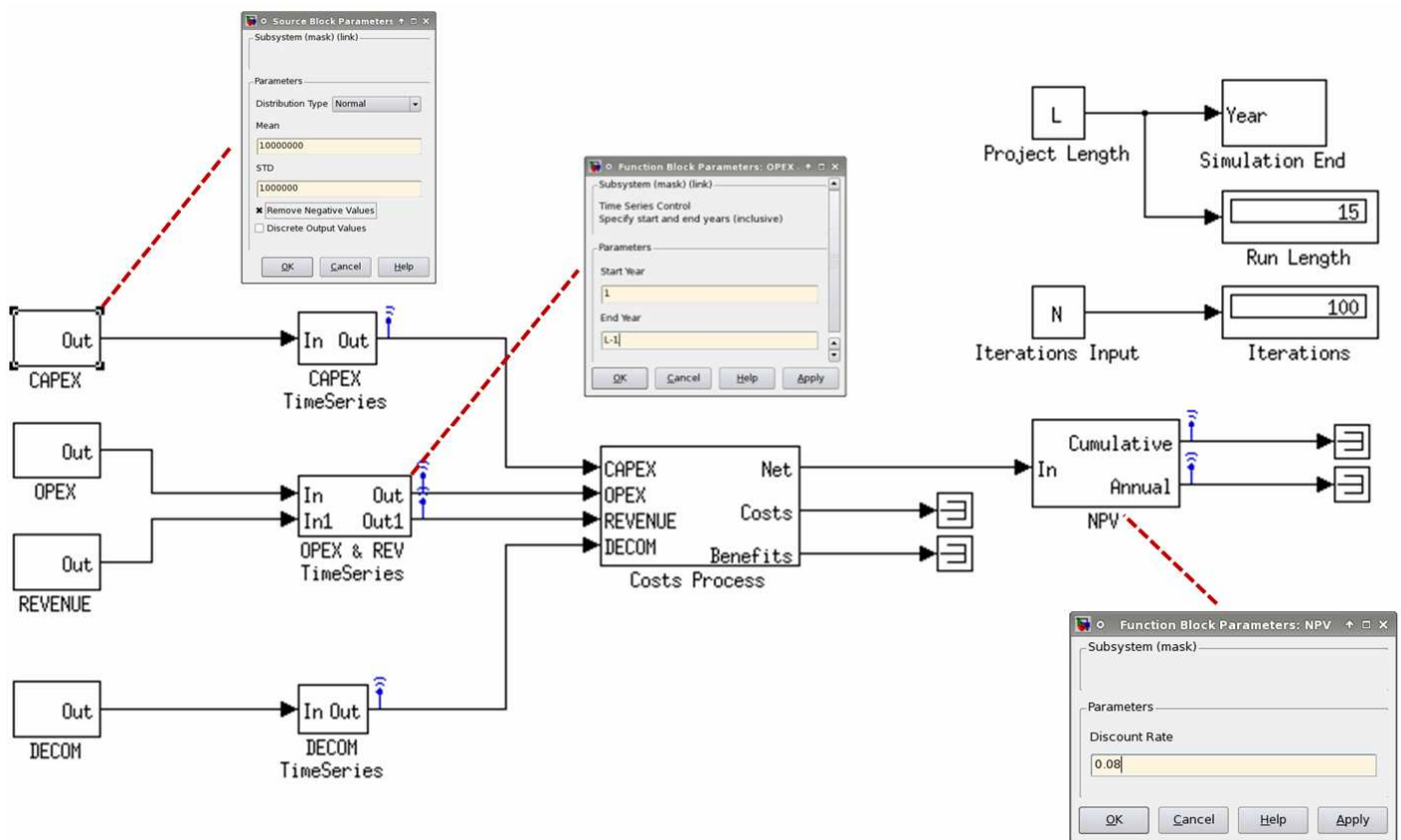

Figure 6 MATLAB Simulink simulation of a simple cost model

5.2 CONCLUDING REMARKS

The aim of the economic appraisal procedure outlined here is to allow equitable comparison of marine energy schemes. The outputs into the model have been separated as far as practicable to produce a generic approach which allows the affect of the fundamental uncertainties in these inputs to be appraised. Many inputs are device and technology specific (e.g. device performance) and must be estimated using data supplied by a device developer. In other cases the inputs are more generic and may be similar (or drawn from the same source) for the majority of devices and deployment scenarios. This approach deliberately intends to allow oversight of the economic analysis procedure and ensure that a consistent methodology is applied wherever possible.

6 REFERENCES

Boud, R. and Thorpe, T. 2003. WAVENET: Results from the work of the European Thematic Network on Wave Energy.

DTI, 2004. *Atlas of UK Marine Energy Resources*, Department of Trade and Industry, London.

Electricité de France, 2009. Private communication.

EMEC , 2009. *Assessment of Tidal Energy Resource*, European Marine Energy Centre, Orkney.

Entec UK Ltd, 2006. *Cost estimation methodology: the Marine Energy Challenge approach to estimating the cost of energy produced by marine energy systems*. Report to Carbon Trust.

Gross, R., Heptonstall, P. and Blyth, W., 2007. *Investment in electricity generation: the role of costs, incentives and risks*, UK Energy Research Centre, London.

Harrison, G. P., Whittington, H. W. and Wallace, A. R., 2003. Climate change impacts on financial risk in hydropower projects, *IEEE Trans. Power Systems*, 18 (4), 1324-1330.

IEA, 2005. *Projected cost of generating electricity*, International Energy Agency

Previsic, M., Bedard, R., Hagerman, G. and Siddiqui, O., 2004. *System Level Design, Performance and Costs for San Francisco California Pelamis Offshore Wave Power Plant*, EPRI.