



South African Bat Fatality Threshold Guidelines

Edition 3

April 2020

Kate MacEwan¹, Jonathan Aronson², Kate Richardson³, Prof. Peter Taylor⁴, Brent Coverdale⁵, Prof. David Jacobs⁶, Lourens Leeuwner⁷, Werner Marais⁸, Dr. Leigh Richards⁹

¹ Inkululeko Wildlife Services (Pty) Ltd; chairperson of the South African Bat Assessment Association

² Arcus Consultancy Services Ltd; panel member of the South African Bat Assessment Association

³ Bats KZN; panel member of the South African Bat Assessment Association

⁴ University of Venda

⁵ Ezemvelo KZN Wildlife; panel member of the South African Bat Assessment Association

⁶ University of Cape Town

⁷ Endangered Wildlife Trust; panel member of the South African Bat Assessment Association

⁸ Animalia Consultants (Pty) Ltd

⁹ Durban Natural Science Museum; panel member of the South African Bat Assessment Association

Citation: MacEwan, K., Aronson, J., Richardson, E., Taylor, P., Coverdale, B., Jacobs, D., Leeuwner, L., Marais, W., Richards, L. 2020. South African Bat Fatality Threshold Guidelines: Edition 3. Published by the South African Bat Assessment Association.

Table of Contents

Introduction	2
Existing Bat Fatality Threshold Approaches	3
Ecoregional Approach	3
Adult Bat Survival.....	4
Recruitment	5
Density Dependant Factors	5
Threshold Calculations	5
How is the Annual Fatality Threshold for a 1 ha site used per Project Site?.....	7
To Which Bats do the Thresholds Apply?.....	8
How can the Threshold Calculations be used towards Cumulative Impact Assessment?	9
What Mitigation Measures Should be Applied?.....	10
Assumptions and Notes.....	11
Acknowledgements.....	11
References	11

Introduction

Bats are particularly susceptible to anthropogenic changes because of their low reproductive rate, longevity, and high metabolic rates (Voigt and Kingston 2016), limiting their ability to recover from declines (Barclay and Harder 2003). Bat fatalities due to wind turbines raise serious concerns about population-level impacts (Barclay and Harder 2003; Frick *et al.* 2017). In addition to natural and other forms of anthropogenic-induced mortality, wind turbine mortality further compounds population declines for many species of bats and warrants mitigation (Arnett *et al.* 2016). In the USA, the hoary bat (*Lasiurus cinereus*), a once widespread and abundant species, is under serious threat due to wind energy and is facing population declines (Frick *et al.* 2017). In an effort to prevent or reduce bat population declines in South Africa (SA), these guidelines propose setting a cap or limit on bat fatalities at wind energy facilities.

Due to the difficulty in determining actual bat population sizes (Lentini *et al.* 2015; Arnett *et al.* 2016), this guideline document uses available data, such as the size of development sites and the bat activity indices (median bat passes per recording hour) associated with the 12 ecoregions (MacEwan *et al.* 2020) as an indication of the bat occupancy of an area, to determine appropriate fatality thresholds that aim to prevent bat population level losses per species or per family group depending on the level to which bat carcasses have been identified to, i.e. to prevent cumulative impacts on bat populations within an ecoregion.

When empirical data is lacking for focal species, data from similar species or structured elicitation of expert opinion can be used for conservation decision-making (Burgman *et al.* 2011; Drescher *et al.* 2013; Martin *et al.*

2012). Such expert elicitation has been used for a variety of conservation problems (Donlan *et al.* 2010; Martin *et al.* 2005; Runge *et al.* 2011; Smith *et al.* 2007). Deciding whether conservation measures are necessary to prevent or mitigate impacts from wind energy development on populations of bats requires use of expert judgments and/or use of data from similar taxa to quantify reasonable scenarios of population growth and losses (Frick *et al.* 2017).

Existing Bat Fatality Threshold Approaches

Typically, bat fatalities at Wind Energy Facilities (WEFs) are reported as fatalities per turbine or fatalities per MW and certain states or provinces in the USA and Canada have set thresholds according to this. For example, in Ontario, Canada, it is 10 bat fatalities per turbine per year and in Pennsylvania, USA, it is 28 bat fatalities per turbine per year. These limits do not take into consideration the number of turbines at the facility, the size of the study area, the density of bats or population sizes in the area or the ecological environment. Arnett *et al.* (2013) state that a more meaningful approach should be taken towards setting thresholds. Barclay *pers comm* at the IBRC 2013 suggested that a game management type approach should be adapted to setting thresholds.

Ecoregional Approach

Biodiversity is not spread evenly across the earth but follows complex patterns determined by climate, vegetation, geology and various other environmental parameters. These patterns are called ecoregions. The World Wildlife Fund (WWF) (<https://www.worldwildlife.org/biomes>) defines an ecoregion as a large unit of land or water containing a geographically distinct assemblage of species, natural communities, and environmental conditions. Ecoregions share a large majority of their species and ecological dynamics, share similar environmental conditions, and interact ecologically in ways that are critical for their long-term persistence. Conservation planning is often considered at the ecoregional level (Anderson 2003; Giakoumi *et al.* 2013; Ricketts and Imhoff 2003)

Biomes are similar to ecoregions but the ecological interactions happen at a much broader and bigger scale and are largely based on climate and vegetation only (<http://pza.sanbi.org/vegetation>). South Africa is made up of only nine biomes (Mucina and Rutherford 2006) but, at a finer scale, consists of 18 ecoregions (Dinerstein *et al.* 2017) (**Figure 1**).

Due to their mobility, bats active within a site could originate from roosts far from the site but likely within the same ecoregion. Therefore, it is not sufficient to simply calculate a threshold for the site, based on site specific data, but rather to consider the fatalities in the context of the bigger ecoregion. Based on acoustic bat activity data gathered from 36 pre-construction and operational bat surveys at WEFs conducted by Inkululeko Wildlife Services (Pty), MacEwan *et al.* (2020) determined median insectivorous bat activity levels for 12 of the 18 SA ecoregions. These data were obtained from 156 microphones in the 0-11 m above ground level height range and 55 microphones in the 50-110 m above ground level height range.

Special Notes:

- **Whilst these guidelines were developed for the impacts of wind energy on bats, because they are area and ecoregion based, they can be applied to any development that may result in bat fatalities.**
- **Owing to the importance of these guidelines, the South African Bat Assessment Association (SABAA) will strive to review and update them every 18 months or as pertinent information becomes available.**
- **Any deviations from using the threshold determination method in these guidelines must be acknowledged and motivated clearly. Such deviation should be ecologically justified. Financial or**

capacity constraints are not acceptable reasons for deviating from the recommended threshold calculations.

- We have mostly used adult survival and young recruitment data from bats in temperate regions of the world because of the lack of published data in SA, but it is likely that SA insectivorous bats of similar sizes have similar survival and recruitment rates.

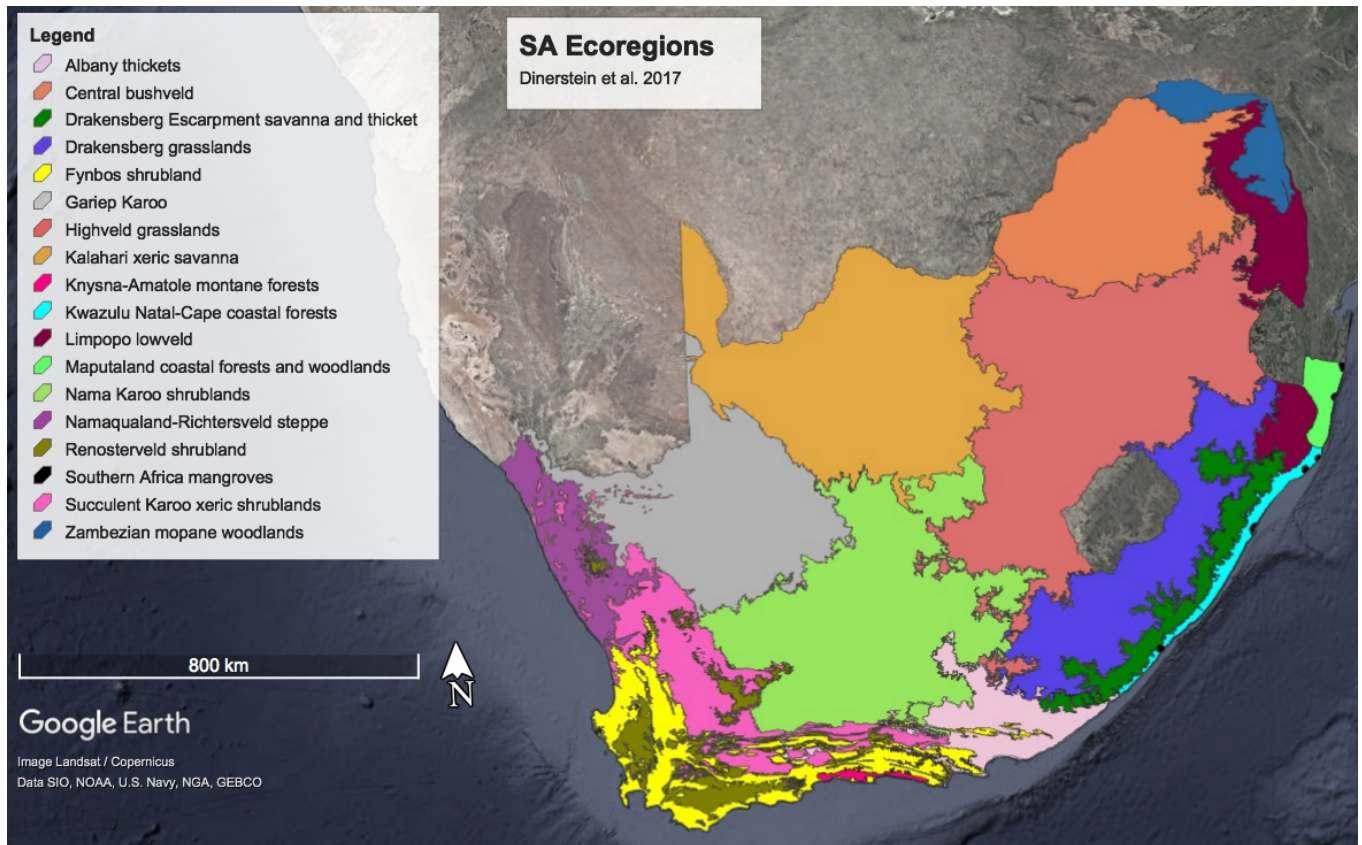

Figure 1 South African Ecoregions according to Dinerstein *et al.* (2017)

Adult Bat Survival

Adult survival in a population of big brown bats could be typical for a growing population of temperate zone insectivorous bats (O'Shea *et al.* 2011). The overall estimate for annual survival of adult females at 5 roosts over the 5-year study period was **0.79** (O'Shea *et al.* 2011). Adult survival was the most important demographic parameter for population growth (O'Shea *et al.* 2011).

The O'Shea *et al.* (2011) result for adult survival was comparable to that calculated using similar analytical methods for an expanding population (due to provision of artificial roosts) of *Plecotus auritus* in England (0.78 +/- 0.04 SE—Boyd and Stebbings 1989), a population of *Nyctalus leisleri* provisioned with roosts in Germany (0.76 +/- 0.04 for females and 0.69 +/- 0.04 for males —Schorcht *et al.* 2009), and an increasing population of *Myotis yumanensis* in California (annual estimates ranging from 0.72 to 0.88—Frick *et al.* 2007). It is also very similar to the mean adult survival rate for a population of *Pipistrellus pipistrellus* in Germany (0.80) (Sendor and Simon 2003) and within the 95% CI of adult survival estimates for *Myotis capaccinii* in Greece (Papadatou *et al.* 2008) and a growing phase of a population of *Myotis lucifugus* in New Hampshire (Frick *et al.* 2010a). An adult survival rate of 0.4-0.8 was demonstrated by Dwyer (1966), Davis (1966), Goehring (1972), Mills *et al.* (1975) and Humphrey and Cope, 1977).

Recruitment

Recruitment is a major component of population dynamics (O'Shea *et al.* 2010). Important factors affecting recruitment are:

- Rates of reproduction of females (breeding probability/ success) (range of 0.64-0.90 (O'Shea *et al.* 2010). We have selected **0.8** as an upper range mean for the calculations.
- Number of young produced in a litter (we used mean litter size of **1.11** (O'Shea *et al.* 2010)¹, and
- Survival of young to reproductive age (first year survival of **0.67** (O'Shea *et al.* 2010))². This is high compared with only a third of female and a quarter of male *Nycteris thebaica* found to survive to one year old (Monadjem 2005) and compared with bat survival rates of 0.1-0.5 in the first year of life by Dwyer (1966), Davis (1966), Goehring (1972), Mills *et al.* (1975) and Humphrey and Cope, 1977).

The above scenarios are typical of a naturally functioning system devoid of climatic or human disturbances. Recruitment will likely be lower in years where there are extreme climatic events or human disturbance in crucial breeding seasons. O'Shea *et al.* (2010), using mark/ recapture of big brown bats, *Eptesicus fuscus*, at maternity colonies in Ft. Collins, Colorado, USA found that first year survival was lowest in bats born during a drought year. Disturbance during pregnancy, lactation and weaning is widely recognized as highly detrimental to recruitment in bat populations (Sheffield *et al.* 1992; McCracken and Wilkinson 2000; Mitchell-Jones *et al.* 2007). Recent studies have shown that changes in seasonal climate, specifically drought, can have negative impacts on fitness in some bat species, including reproductive rates (Adams 2010) and annual survival (Frick *et al.* 2010b). Therefore, it is important that during these environmental conditions, a more conservative approach is adapted to the use of thresholds.

Density Dependant Factors

We acknowledge that density-dependant factors cannot be ruled out, however, due to the limitations of available data and an understanding of such factors in most bat species globally, and particularly in South Africa, we chose not to include the additional complexity of potential density-dependent population growth.

Threshold Calculations

Taylor *et al* (2007) used radar data from an Environmental Impact Assessment for Dube Tradeport (site of King Shaka International Airport, Durban) to calculate the nightly total number of tracked individual bats for a nautical mile radius (1 078 ha) for three nights in February 2007. The mean result for three sites was 16 361 bats per night. This gives a mean density of $16\ 361/1\ 078 = 15$ bats/ha for all heights. This value is applicable to the KwaZulu-Cape Coastal Forests ecoregion. Using the proportional activity for 12 of the 18 SA ecoregions (based on the median bat passes per recording hour in each ecoregion from MacEwan *et al.* (2020)) and the known bat occupancy for KwaZulu-Cape Coastal Forests ecoregion, we calculated proportional bat occupancies per 1 ha for each ecoregion (**Table 1**). To address concerns regarding the data from Taylor *et al* (2007), literature shows us that the value of 15 bats/ha is in line with a value of 12 bats/ha estimated for a population of pipistrelles in bat boxes in a rice growing area of Spain (Puig-Montserrat *et al* 2015) and the range of

¹ This is a high average birth rate for insectivorous bats, considering that the only African example we found was Monadjem (2005), who showed an average litter size of 0.9 for *Nycteris thebaica*.

² This is a high juvenile survival, considering:

- Survival rates were low during the first year of life (0.1-0.5), high during the subsequent 3-5 years (0.4-0.8) and then decreasing, often more rapidly in females than in males (Dwyer, 1966; Davis, 1966; Goehring, 1972; Mills *et al.*, 1975; Humphrey and Cope, 1977).

occupancies in **Table 1** is in line with the 0.01 to 22 bats/ha synthesised by Gaisler (1979) from 15 bat species from the USA, USSR, Costa Rica, Rumania, Czechoslovakia and Australia. He confirms that warmer regions generally have higher bat densities. This is consistent with our data.

To determine the total number of hectares that are applicable for individual sites in the above threshold calculations, it should be the area of influence of the wind turbines. Consider **Figure 2** below: the physical footprint of the turbines is 300m X 300m = 9 ha (the black lines), but the area of influence of the turbines would include the full rotor swept area - 450m X 450m = 16 ha (the dotted red lines). The correct area to use would be the area of influence, i.e. 16 ha.

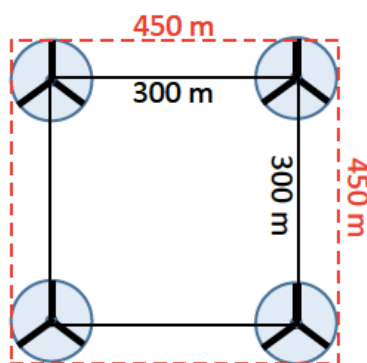

Figure 2 Hypothetical illustration of the turbine footprint vs. area of influence of the turbine (Illustration credit: SAWEA)

Table 1: Bat Occupancy per Ecoregion

Terrestrial Ecoregions based on Dinerstein <i>et al.</i> (2017)	Median Bat Passes per recording hour at 0-11 m above ground level	Proportion of bats per Ecoregion	Proportional Bat occupancy per 1 ha based on Taylor <i>et al.</i> (2007)
Fynbos Shrubland	1.18	2.44%	0.78
Albany thickets	1.2	2.48%	0.80
Succulent Karoo Xeric shrublands	0.08	0.17%	0.05
Renosterveld shrubland	4.17	8.63%	2.77
Namaqualand-Renosterveld steppe	0.18	0.37%	0.12
Nama Karoo shrublands	0.8	1.66%	0.53
Maputuland Coastal Forests and Woodlands	15.25	31.55%	10.14
Limpopo Lowveld	1.47	3.04%	0.98
Kwazulu Natal-Cape Coastal Forests	22.57	46.70%	15.00
Highveld Grasslands	0.59	1.22%	0.39
Drakensberg Grasslands	0.18	0.37%	0.12
Drakensberg Escarpment savanna	0.66	1.37%	0.44

Using the calculations in Spreadsheet 1 (available on request) on a theoretical population of 1000 bats and an assumed 1:1 sex ratio, the following situation can be observed:

- Natural Population Dynamics:
 - Using the results from O’Shea *et al.* (2010 and 2011), under natural conditions, insectivorous bat populations will **grow steadily** over time at a rate of approximately 2.5% per annum. This is generous compared to the rate of 1% quoted by Frick *et al.* (2017).
- With 1% additional losses due to anthropogenic pressures:

- Insectivorous bat populations will **grow slower** over time at a rate of approximately 1.2% per annum.
- With 2% additional losses due to anthropogenic pressures:
 - Insectivorous bat populations **decline slowly** at a rate of approximately 0.1% per annum.
- With 3% additional losses due to anthropogenic pressures:
 - Bat populations **will decline** over time at a rate of approximately 1.4% per annum.
- With 5% additional losses due to anthropogenic pressures:
 - Bat populations **will decline** over time at a rate of approximately 4.0% per annum.
- With 10% additional losses due to anthropogenic pressures:
 - Bat populations **will decline** over time at a rate of approximately 10.5% per annum.
- With 15% additional losses due to anthropogenic pressures:
 - Bat populations **will decline** over time at a rate of approximately 17.0% per annum.

Because declines start at 2%, this is set as the annual fatality threshold for preventing unsustainable losses on the total population. The 2% values per 1 ha per ecoregion are presented in **Table 2** below:

Table 2: Bat Fatality Thresholds per Ecoregion

Terrestrial Ecoregions based on Dinerstein <i>et al.</i> (2017)	2% of the Bats per 1 ha, i.e. Annual Fatality Threshold for a 1ha site *
Fynbos Shrubland	0.015685
Albany thickets	0.015950
Succulent Karoo Xeric Shrublands	0.001063
Renosterveld Shrubland	0.055428
Namaqualand-Renosterveld Steppe	0.002393
Nama Karoo Shrublands	0.010634
Maputuland Coastal Forests and Woodlands	0.202703
Limpopo Lowveld	0.019539
Kwazulu Natal-Cape Coastal Forests	0.300000
Highveld Grasslands	0.007842
Drakensberg Grasslands	0.002393
Drakensberg Escarpment savanna	0.008773

* These thresholds are based on corrected fatalities per least concern bat species or family, corrected for biases such as scavenger removal, searcher efficiency and density-weighted proportion. Fatality estimates should be calculated using GenEst (Dalthorp *et al.* 2018).

How is the Annual Fatality Threshold for a 1 ha site used per Project Site?

Example 1

For project boundary area that is 2000 ha and is all situated in Renosterveld Shrubland, the calculations would be as follows: $2000 \times 0.055428 = 110.86$ rounded off to 111. Therefore, in total, bat fatalities per least concern insectivorous bat species or family should not exceed 111 bats per annum. If 112 or more bats of one species or family are killed per annum, mitigation should be applied.

Example 2

For project boundary area that is 3000 ha and 1500 ha of the site is situated in Succulent Karoo Xeric Shrublands and 1500 ha of the site is situated in Nama Karoo Shrublands, the calculations would be as follows:

- Succulent Karoo Xeric Shrublands portion: $1500 \times 0.001063 = 1.60$ rounded off to 2
- Nama Karoo Shrublands portion: $1500 \times 0.010634 = 15.95$ rounded off to 16

Therefore, in total, bat fatalities per least concern insectivorous bat species or family should not exceed 18 bats per annum. If 19 or more bats of one species or family are killed per annum, mitigation should be applied.

Which Bats do the Thresholds Apply to?

The thresholds apply to all insectivorous bat species not included in the **Table 3** below. The species in **Table 3** are either of conservation importance or are rare or range-restricted bats. The threshold applies to individual species or family groups³ killed annually per 1 ha and is based on values adjusted for biases such as searcher efficiency and carcass persistence. Fatality estimates should be calculated using GenEst (Dalthorp *et al.* 2018).

One or more fatalities per site during a 12 month period of a species listed in **Table 3** should trigger mitigation.

With regard to fruit bats, if more than one carcass is found at a particular turbine per annum, mitigation should be triggered at that turbine in the month/s that the carcasses were found.

Table 3: List of Bats where 1 Fatality per Annum should Trigger Mitigation

Species Name	Common Name
<i>Cistugo lesueuri</i>	Lesueur's Hairy Bat
<i>Cistugo seabrae</i>	Angolan Hairy Bat
<i>Cloeotis percivali</i>	Short-eared Trident Bat
<i>Kerivoula argentata</i>	Damara Woolly Bat
<i>Laephotis namibensis</i>	Namib Long-eared Bat
<i>Laephotis wintoni</i>	De Winton's Long-eared Bat
<i>Miniopterus fraterculus</i>	Lesser Long-fingered Bat
<i>Miniopterus inflatus</i>	Greater long-fingered bat
<i>Neoromicia rendalli</i>	Rendall's serotine
<i>Nycteris woodi</i>	Wood's Slit-faced Bat
<i>Otomops martiensseni</i>	Large-eared free-tailed Bat
<i>Rhinolophus blasii</i>	Peak-saddle Horseshoe Bat
<i>Rhinolophus capensis</i>	Cape Horseshoe Bat
<i>Rhinolophus cohenae</i>	Cohen's Horseshoe Bat
<i>Rhinolophus denti</i>	Dent's Horseshoe Bat
<i>Rhinolophus smithersi</i>	Smither's Horseshoe Bat
<i>Rhinolophus swinnyi</i>	Swinny's Horseshoe Bat
<i>Scotoecus albofuscus</i>	Thomas' House Bat
<i>Scotophilus nigrita</i>	Giant Yellow House Bat
<i>Tadarida ventralis</i>	Giant Free-tailed Bat
<i>Taphozous perforatus</i>	Egyptian Tomb Bat

³ The reason family groups are also mentioned in that often carcasses cannot be identified to species level without skeletal or DNA testing at a museum.

How can the Threshold Calculations be used towards Cumulative Impact Assessment?

The threshold calculations can and should be used both at the site/ project specific level (this is what the developer/ operator of that specific site is responsible for) and at the regional/ cumulative impact assessment level (this is what the collective of developers/ operators and government for that region are responsible for). Collective mitigation efforts should be applied proportionately amongst the wind farms concerned, and wind farms who are adhering to their specific threshold should not be penalised for excessive fatalities occurring at another wind farm.

Because the threshold calculations are area and ecoregion based, they can be adapted to any given area within a specific ecoregion. The aim is to calculate what number of fatalities may lead to population level declines for a given area, based on the principles and assumptions presented in this document.

Whilst the Department of Environment, Forestry and Fisheries (DEFF) often use 30 km as the radius for which cumulative impacts should be considered around a particular development, this distance is arbitrary, especially when assessing bats. We recommend that the cumulative assessment be conducted for an area that has ecological significance or if unknown a 100km radius is used.

For examples on cumulative calculations, refer to **Figure 3** and the explanation below.

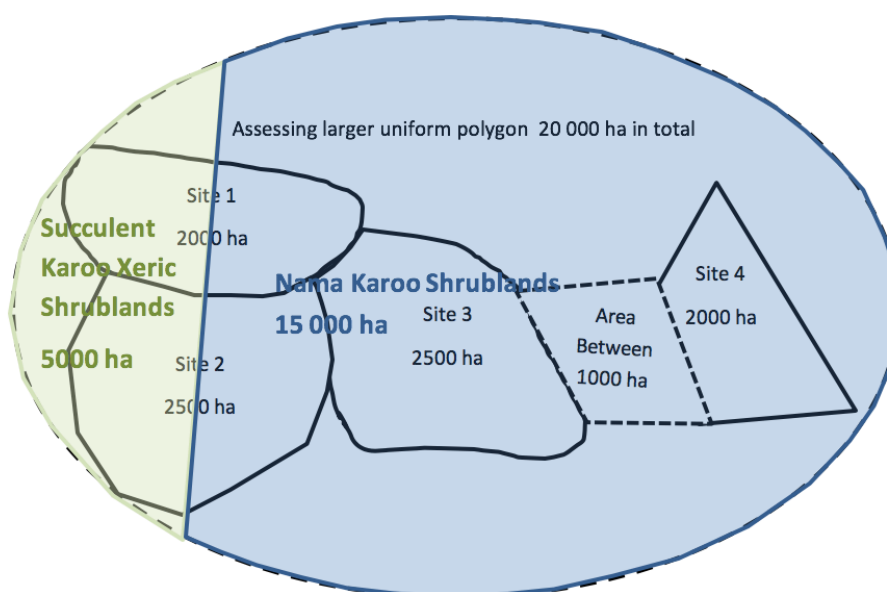

Figure 3 Hypothetical illustration of multiple project areas together

In **Figure 3** above, there are four project sites, each with their own area of influence. The calculations of the thresholds for each site would be done as follows:

Site 1

- Succulent Karoo Xeric Shrublands portion: $1000 \times 0.001063 = 1.6$ rounded off to 2
- Nama Karoo Shrublands portion: $1000 \times 0.010634 = 10.63$ rounded off to 11

Therefore, in total, bat fatalities per least concern insectivorous bat species or family should not exceed 13 bats per annum. If 14 or more bats of one species or family are killed per annum, mitigation should be applied.

Site 2

- Succulent Karoo Xeric Shrublands portion: $1200 \times 0.001063 = 1.28$ rounded off to 1
- Nama Karoo Shrublands portion: $800 \times 0.010634 = 8.51$ rounded off to 9

Therefore, in total, bat fatalities per least concern insectivorous bat species or family should not exceed 10 bats per annum. If 11 or more bats of one species or family are killed per annum, mitigation should be applied.

Site 3

Site 3 only falls in one ecoregion (Nama Karoo Shrublands), therefore, $2500 \times 0.010634 = 26.58$ rounded off to 27. If 28 or more bats are killed at that site per annum, mitigation should be applied.

Site 4

Site 4 only falls in one ecoregion (Nama Karoo Shrublands), therefore, $2000 \times 0.010634 = 21.27$ rounded off to 21. If 22 or more bats are killed at that site per annum, mitigation should be applied.

In order to calculate Cumulative Impact, one can assess the situation in two ways, depending on which is most ecologically appropriate or depending on the objectives of the cumulative assessment:

Scenario 1

A tight fitting polygon is drawn around all of the sites you are interested in and the sum of the thresholds plus the threshold for the area in between is added to calculate the total threshold for that area, e.g.

- Threshold Site 1 + Threshold Site 2 + Threshold Site 3 + Threshold Site 4 + Threshold Area Between = Total Threshold, i.e.
- $13 + 10 + 27 + 21 + 11 = 82$, i.e.

The fatalities for the total cumulative area should not exceed 83 least concern insectivorous bat species or members of a bat family. If 84 or more bats of one species or family are killed per annum, individual or collective mitigation measures should be put in place, depending on which facilities are exceeding their individual thresholds.

Scenario 2

You may be interested in looking at a bigger polygon for an area – either a municipal area or an ecoregion, etc. Draw your polygon around the sites in whatever shape suits your objectives. Then, calculate the threshold for that entire area. An oval shape was drawn as the example in **Figure 1** and the calculations would be as follows:

- Succulent Karoo Xeric Shrublands portion: $5000 \times 0.001063 = 5.32$ rounded off to 5
- Nama Karoo Shrublands portion: $15000 \times 0.010634 = 159.5$ rounded off to 160

Therefore, in total, bat fatalities for this total area should not exceed 165 insectivorous bats per annum. If 166 or more bats are killed per annum, collective mitigation and other conservation efforts should be applied.

It is important to remember: These calculations do not involve the number of turbines or MW. They are purely based on how many bats, in addition to natural population losses, can be removed from the area of interest, before population declines may arise. Therefore, they can be applied to any development that may result in bat fatalities.

What Mitigation Measures Should be Applied?

Turbine specific and weather specific mitigation measures should be implemented if annual adjusted fatalities per 1 ha at any wind energy facility exceed the thresholds provided in **Table 2**. Whilst the implementation of

mitigation is triggered by exceeding an overall annual threshold per species or family group, the type and intensity of mitigation, and at which turbines and during which periods it must be implemented, must be based on a combination of actual carcass data found at specific turbines and the activity data in relation to weather conditions, times of night and times of year and based on the unadjusted fatality data per turbine.

Based on site specific results and taking into consideration which turbines had the highest fatalities and which weather parameters bats were most active in, turbine specific mitigation measures should be implemented. For more information and guidance on the mitigation measures please see Aronson *et al.* (2018).

Assumptions and Notes

It is very important to note the following assumptions and limitations relating to the threshold calculations:

- Sex ratios were assumed to be 50% females/ 50% males.
- The threshold calculations are based on common insectivorous crevice/ roof / tree roosting species only. It does not apply to frugivorous species, conservation important or rare/ range restricted species.
- Rates of reproduction of females (breeding probability/ success) was selected 0.8 as an upper range mean between 0.64 – 0.90 (O’Shea *et al.* 2010). However, this is believed to be high and can be adjusted if better information is available.
- If the eco-region you are working in does not have a threshold provided in **Table 2** above, the threshold should be calculated based on 2% of the median of annual bat passes per recording hour for your site and multiply it by the size of the site in hectares, i.e. use the site specific bat activity data and a proportional approach, as demonstrated in **Tables 1** and **2**.
- We recommend using the General Estimator (GenEst) (Dalthorp *et al.* 2018) to calculate fatality estimates per species or family groups.
- When using fatality estimators, a lower fatality limit, upper fatality limit and a median fatality is calculated at the 95% confidence interval. If the variance/difference between the lower and the upper confidence limit does not exceed 50%, then the median fatality estimate value should be used. However, should the variance/difference between the lower and upper limit exceed 50%, then the lower fatality limit should be used.
- To determine the total number of hectares that are applicable in the above threshold calculations, it is defined as the area inside the wind farm boundary area (i.e. the total area where wind turbines may be placed within a given boundary area). Linear power-line routes or roads outside of the wind farm boundary area should not be included in the calculations.

Acknowledgements

The authors wish to thank Wendy White for her initial thoughts on bat population calculations.

References

- Adams, R.A. 2010. Bat reproduction declines when conditions mimic climate change projections for western North America. *Ecology* 91:2437–2445
- Anderson, M.G. 2003. Ecoregional conservation: A comprehensive approach to conserving biodiversity. The Nature Conservancy, Northeast & Caribbean Division, Boston, MA.
- Aronson, J., Sowler, S. and K. MacEwan. 2018. Mitigation Guidance for Bats at Wind Energy Facilities in South Africa, 2nd Edition. South African Bat Assessment Association.

- Arnett, E.B. and Baerwald, E.F. 2013. Impacts of wind energy development on bats: Implications for conservation. Pp. 435–456, In R.A. Adams and S.C. Pederson (Eds.). *Bat Evolution, Ecology, and Conservation*, 1st Edition. Springer Science & Business Media, New York, NY. 547 pp.
- Arnett, E.B., Baerwald, E.F., Mathews, F., Rodrigues, L., Rodríguez-Durán, A., Rydell, J., Villegas-Patracca, R. and Voigt C.C. 2016. Impacts of Wind Energy Development on Bats: A Global Perspective. In: Voigt, C.C. and Kingston, T. (eds) *Bats in the Anthropocene: Conservation of Bats in a Changing World*. Springer Cham Heidelberg New York Dordrecht London.
- Barclay, R.M.R., and Harder, L.D. 2003. Life histories of bats: life in the slow lane. In Kunz T.H. and Fenton M.B. (eds) *Bat Ecology*. University of Chicago Press.
- Boyd, I.L. and Stebbings, R.E. 1989. Population changes of brown long-eared bats (*Plecotus auritus*) in bat boxes at Thetford forest. *J Appl Ecol* 26:101–112.
- Burgman, M., Carr, A., Godden, L., Gregory, R., McBride, M., Flander, L., Maguire, L. 2011. Redefining expertise and improving ecological judgment. *Conserv. Lett.* 4:81–87. <http://dx.doi.org/10.1111/j.1755-263X.2011.00165.x>.
- Dalthorp, D., Simonis, J., Huso, M., Madsen, L., Rabie, P., Mintz, J., Wolpert, R., Studyvin, J., and F. Korner-Nievergelt, F. 2018. GenEst: Generalised Fatality Estimator. R package (most up to date version).
- Dinerstein, E., Olson, A., Joshi, C., Vynne, D. N. Burgess, E. Wikramanayake, N. Hahn, S. Palminteri, P. Hedao, R. Noss, M. Hansen, H. Locke, E.C. Ellis, B. Jones, C.V. Barber, C Kormos, V. Martin, E. Crist, W. Sechrest, L. Price, J.E.M. Baillie, D. Weeden, K. Suckling, C. Davis, N. Sizer, R. Moore, D. Thau, T. Birch, P. Potapov, S. Turubanova, A. Tyukavina, N. de Souza, L. Pintea, J.C. Brito, O.A. Llewellyn, A.G. Miller, A. Patzelt, S.A. Ghazanfar, J. Timberlake, H. Kloser, Y. Shennan-Farpon, R. Kindt, J.P.B. Lilleso, P. van Breugel, L. Graudal, M. Voge, K.F. Al-Shammari and M. Saleem. 2017. An Ecoregion-Based Approach to Protecting Half the Terrestrial Realm. *BioScience*.167: 534-545.
- Donlan, C.J., Wingfield, D.K., Crowder, L.B., Wilcox, C. 2010. Using expert opinion surveys to rank threats to endangered species: a case study with sea turtles. *Conserv. Biol.* 24:1586–1595. <http://dx.doi.org/10.1111/j.1523-1739.2010.01541.x>.
- Drescher, M., Perera, A.H., Johnson, C.J., Buse, L.J., Drew, C.A. and Burgman, M.A. 2013. Toward rigorous use of expert knowledge in ecological research. *Ecosphere* 4:1–26.
- Frick, W.F., Rainey, W.E. and Pierson, E.D. 2007. Potential effects of environmental contamination on Yuma myotis demography and population growth. *Ecological Applications* 17(4): 1213-1222. PDF
- Frick, W.F., Reynolds, D.S. and Kunz, T.H. 2010. Influence of climate and reproductive timing on demography of little brown myotis *Myotis lucifugus*. *J Anim Ecol* 79:128–136
- Frick, W.F., Pollock, J.F., Hicks, A.C., Langwig, K.E., Reynolds, D.S., Turner, G.G., Butchkoski, C.M., Kunz, T.H. 2010. An emerging disease causes regional population collapse of a common North American bat species. *Science* 329:679–682. <http://dx.doi.org/10.1126/science.1188594>.
- Frick, W.F., Baerwald, E.F., Pollock, J.F., Barclay, R.M.R., Szymanski, J.A., Weller, T.J. Russell, A.L., Loeb, S.C., Medellin and R.A. McGuire, L.P. 2017. Fatalities at wind turbines may threaten population viability of a migratory bat. *Biological Conservation* 209:172–177
- Lentini, P.E., Bird, T.J., Griffiths, S.R., Godinho, L.N., Wintle, B.A. 2015. A global synthesis of survival estimates for microbats. *Biol. Lett.* 11:20150371. <http://dx.doi.org/10.1098/rsbl.2015.0371>.
- Martin, T.G., Kuhnert, P.M., Mengersen, K. and Possingham, H.P. 2005. The power of expert opinion in ecological models using bayesian methods: impact of grazing on birds. *Ecol. Appl.* 15:266–280. <http://dx.doi.org/10.1890/03-5400>.
- Martin, T.G., Burgman, M.A., Fidler, F., Kuhnert, P.M., Low-Choy, S., McBride, M. and Mengersen, K. 2012. Eliciting expert knowledge in conservation science. *Conserv. Biol.* 26:29–38. <http://dx.doi.org/10.1111/j.1523-1739.2011.01806.x>.
- McCracken, G. and Wilkinson, G. 2000. Bat mating systems. In: Crichton EG, Krutzsch PH (eds) *Reproductive biology of bats*. Academic, New York, NY

- Mitchell-Jones, A.J., Bihari, Z., Masing, M. *et al.* 2007. *Protecting and managing underground sites for bats*. EUROBATS Publication series No. 2. UNEP/EUROBATS Secretariat, Bonn, Germany.
- O'Shea, T.J., Ellison, L.E., Neubaum, D.J., Neubaum, M.A., Reynolds, C.A. and Bowen, R.A. 2010. Recruitment in a Colorado population of big brown bats: breeding probabilities, litter size, and first-year survival. *J Mammal* 91:418–442
- O'Shea, T.J., Ellison, L.E. and Stanley, T.R. 2011. Adult survival and population growth rate in Colorado big brown bats (*Eptesicus fuscus*). *J Mammal* 92:433–443
- Papadatou, E., Butlin, R.K., Altringham, J.D. 2008 Seasonal roosting habits and population structure of the long-fingered bat *Myotis capaccinii* in Greece. *J Mammal* 89:503–512.
- Puig-Montserrat, X., Torre, I., López-Baucells, A., Guerrieri, E. Monti, M.M., Ràfols-García, R., Ferrer, X., Gisbert, D. and Flaquer, C. Pest control service provided by bats in Mediterranean rice paddies: linking agroecosystems structure to ecological functions. *Mammalian Biology* 80: 237–245.
- Ricketts, T. and M. Imhoff. 2003. Biodiversity, urban areas, and agriculture: locating priority ecoregions for conservation. *Conservation Ecology* 8(2): 1. [online] URL: <http://www.consecol.org/vol8/iss2/art1/>
- Runge, M.C., Converse, S.J. and Lyons, J.E. 2011. Which uncertainty? Using expert elicitation and expected value of information to design an adaptive program. *Biol. Conserv.* 144:1214–1223. <http://dx.doi.org/10.1016/j.biocon.2010.12.020>.
- Schorcht, W., Bontadina, F. and Schaub, M. 2009. Variation of adult survival drives population dynamics in a migrating forest bat. *J. Anim. Ecol* 78:1182–1190.
- Sendor, T. and Simon, M. 2003. Population dynamics of the pipistrelle bat: effects of sex, age and winter weather on seasonal arrival. *J Anim Ecol* 72:308–320
- Sheffield, S.R., Shaw J.H., Heidt G.A. *et al.* 1992. Guidelines for the protection of bat roosts. *J Mammal* 73:707–710
- Smith, C.S., Howes, A.L., Price, B. and McAlpine, C.A. 2007. Using a Bayesian belief network to predict suitable habitat of an endangered mammal – the Julia Creek dunnart (*Sminthopsis douglasi*). *Biol. Conserv.* 139:333–347. <http://dx.doi.org/10.1016/j.biocon.2007.06.025>.
- Taylor *et al* 2007. Radar data from an Environmental Impact Assessment for Dube Tradeport (site of King Shaka International Airport, Durban).
- Voigt, C.C. and Kingston, T. 2016. Bats in the Anthropocene. In: Voigt, C.C. and Kingston, T. (eds) *Bats in the Anthropocene: Conservation of Bats in a Changing World*. Springer Cham Heidelberg New York Dordrecht London.
- Williams, Laura & Zazanashvili, Nugzar & Sanadiradze, Giorgi & Kandaurov, Andrei. 2006. An Ecoregional Conservation Plan for the Caucasus – 2nd Edition. Published by the WWF.