



Illustration by Josh Bauer/NREL



Summary of Existing Foundations, Installation Methods, and Effects

U.S. Offshore Wind Noise Reduction Workshop

National Renewable Energy Laboratory (NREL) & Pacific Northwest National Laboratory (PNNL)



Ralph Grismala, P.E.
Civil and Environmental Engineer, ICF

12 December 2022

Monopile Foundations

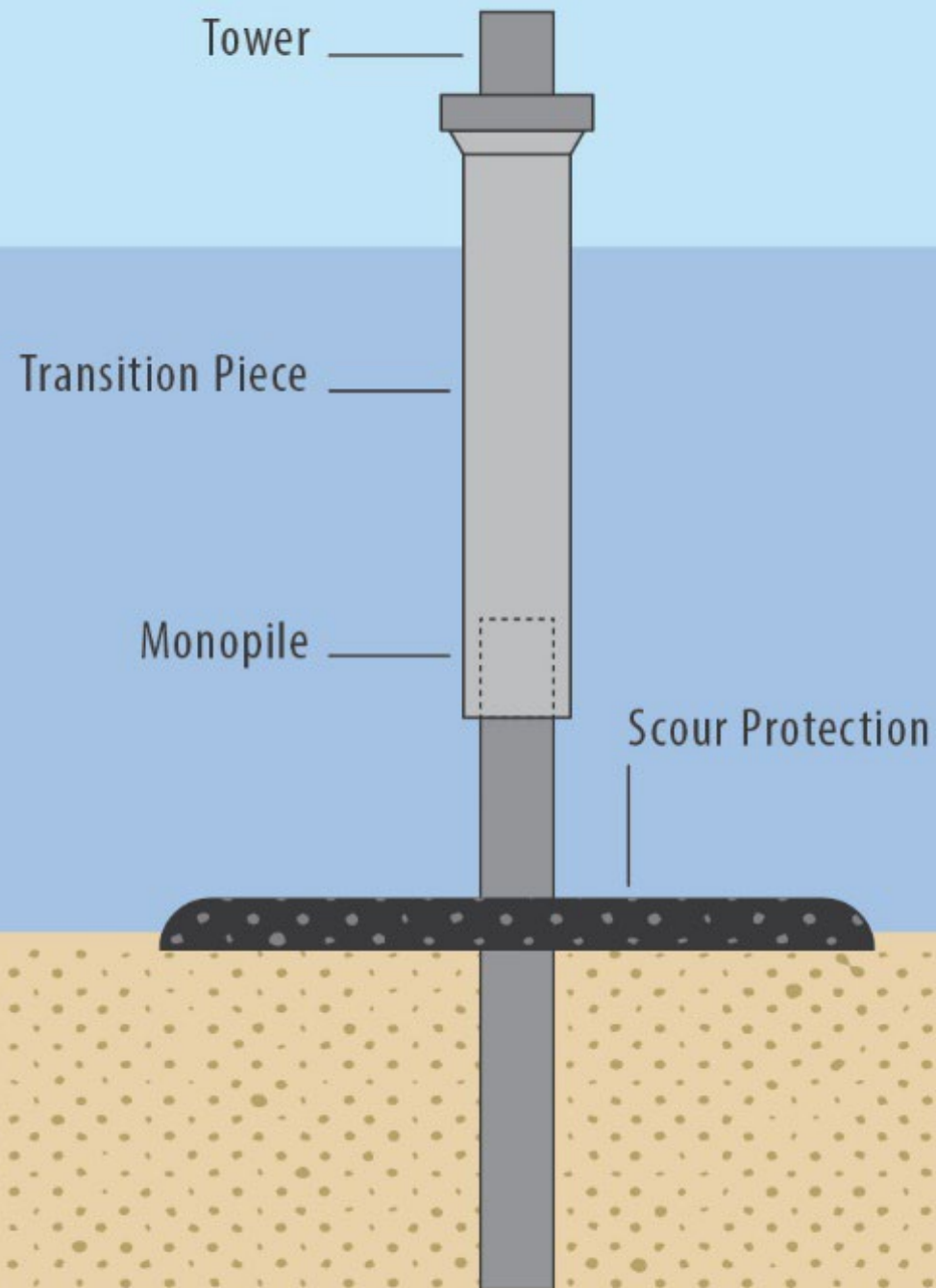

Description

- Single, large-diameter, steel pipe pile driven into the seabed
- Current designs include steel monopiles up to about 10 m (33 ft) in diameter
- Feasible in waters up to ~60 m (200 ft) deep

Installation

- Usually installed with pile-driving hammers or vibratory methods, although sometimes drilled

Acoustic Effects

- Installation noise may harm or displace marine animals.
- Impact pile driving creates the largest effects. Effects from vibratory pile driving or drilling would be smaller.

Jacket Foundations

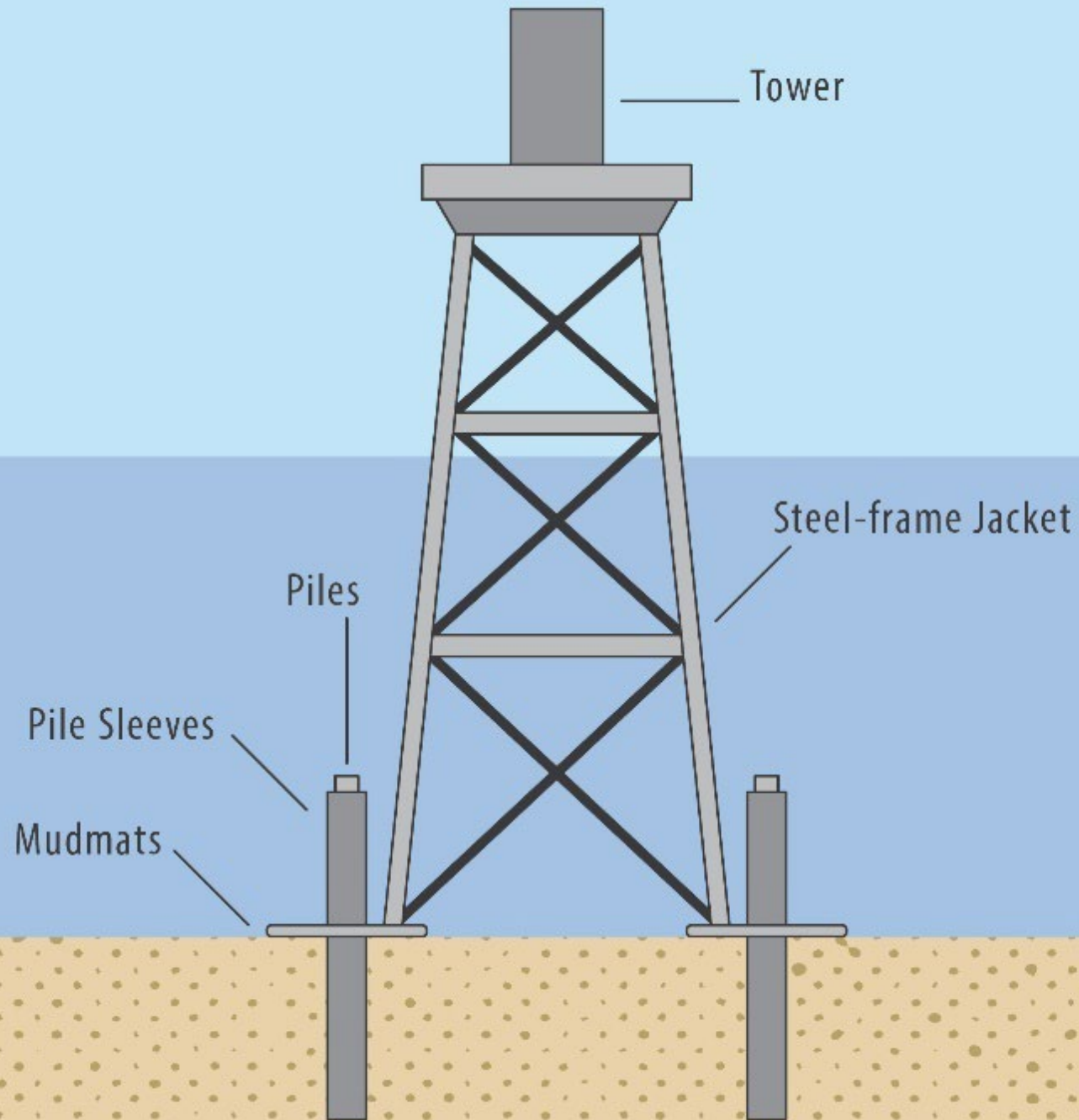

Description

- Lattice-truss structures similar to the designs of many offshore oil platforms
- Usually four-legged, with tubular legs at the corners and smaller-diameter horizontal cross pieces and diagonal struts

Installation

- Jacket anchored to the seabed with piles
- Piles may be driven before placement of the jacket using a template on the seabed, driven through the tubular jacket legs, or installed through external pile guides

Acoustic Effects

- Similar effects to monopile though the spatial scale of effects would be smaller.

Tripod Foundations

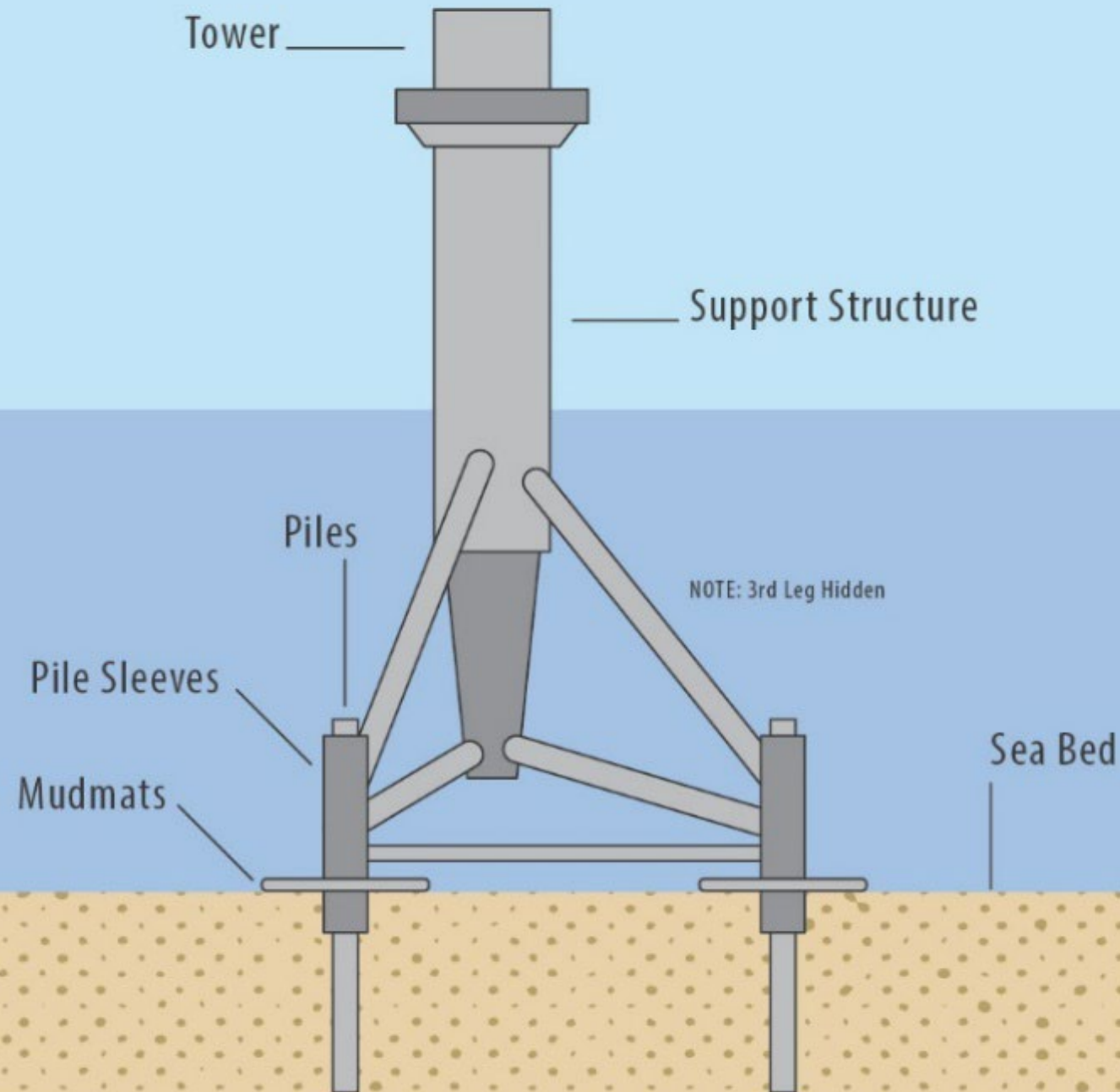

Description

- Tetrahedral (pyramid-shaped) space frame constructed from tubular steel members
- Cylindrical central column similar to a monopile, but it does not enter the seabed

Installation

- Tripod anchored with piles or suction caissons at the corners of the triangular base

Acoustic Effects

- Piling has similar effects to monopiles though the spatial scale of effects would be smaller.
- Suction caissons cause minimal acoustic effects, relative to impact pile driving.

Tri-pile Foundations

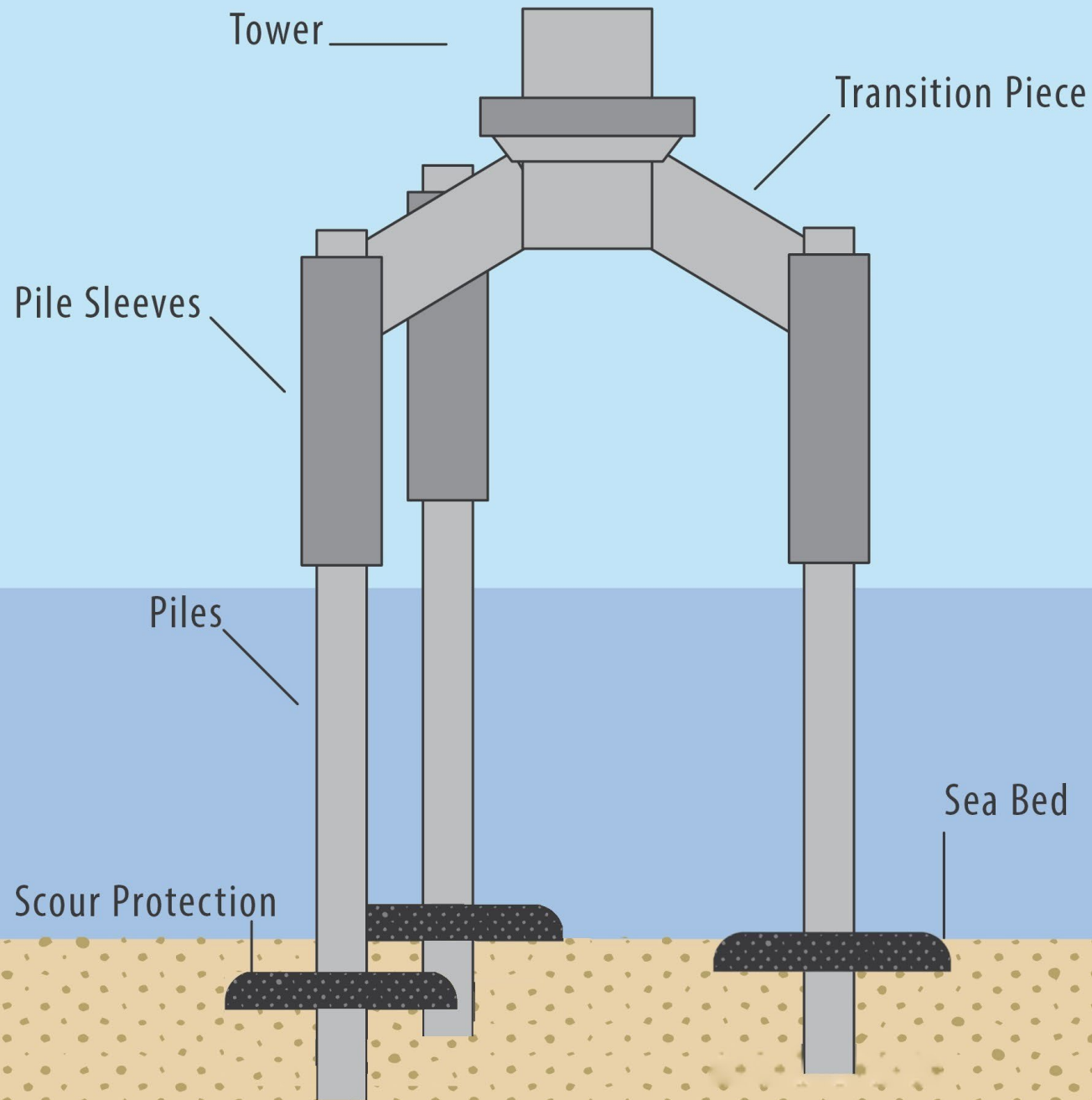

Description

- Three cylindrical pile legs that connect to a transition piece above the waterline, forming a space frame that supports the wind turbine tower and turbine

Installation

- Three foundation piles are hammered or vibrated into the seabed using a guide frame to maintain proper alignment to set the transition piece atop the piles.

Acoustic Effects

- Piling has similar effects to monopiles though the spatial scale of effects would be smaller.

Jack-Up Foundations

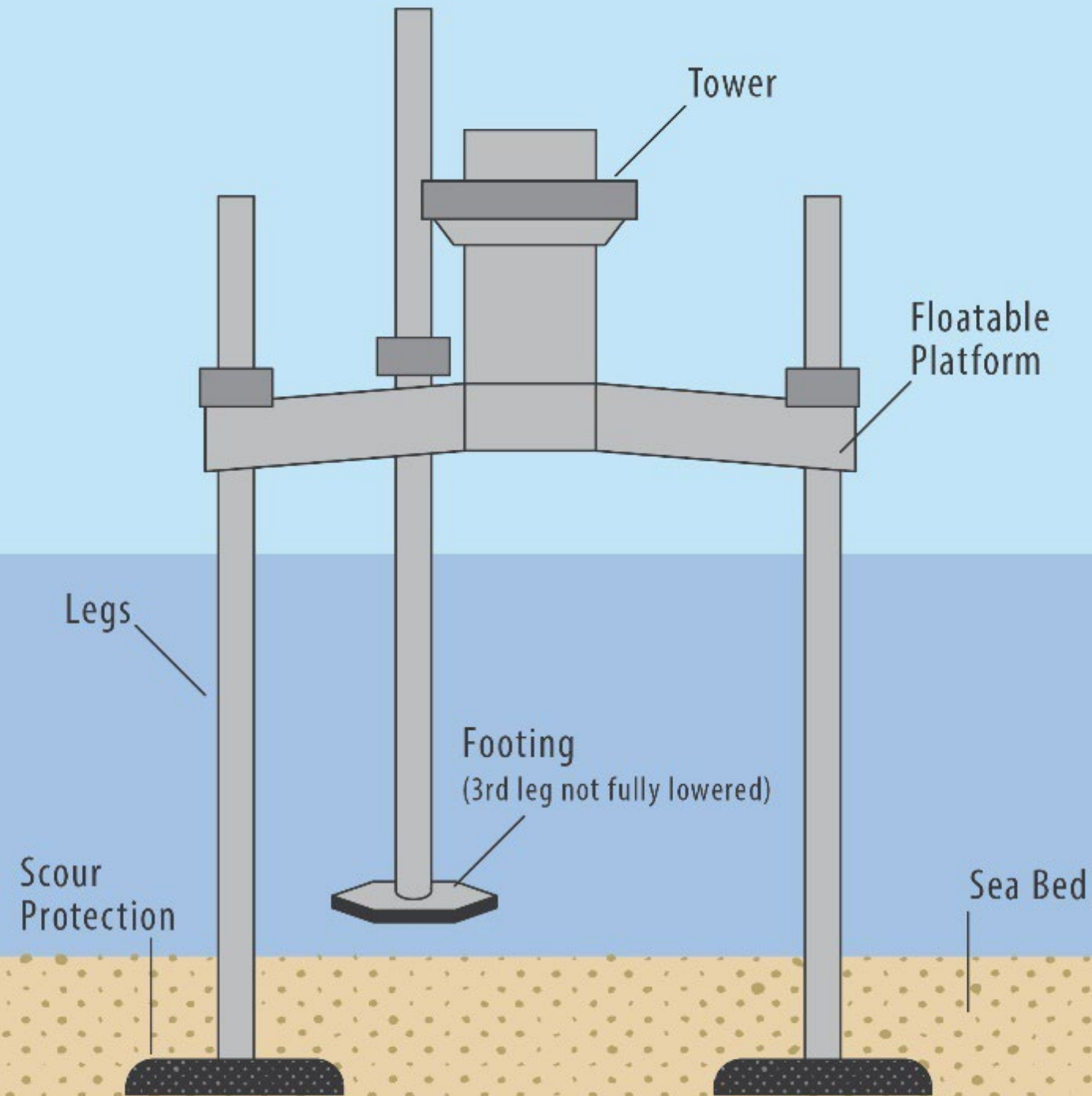

Description

- Floatable platform with three or four legs that can be raised and lowered relative to the platform

Installation

- The jack-up legs are lowered to the seabed
- The hull is jacked-up above the water surface

Acoustic Effects

- Jack-up foundations cause minimal acoustic effects, relative to impact pile driving

Suction Bucket Foundations

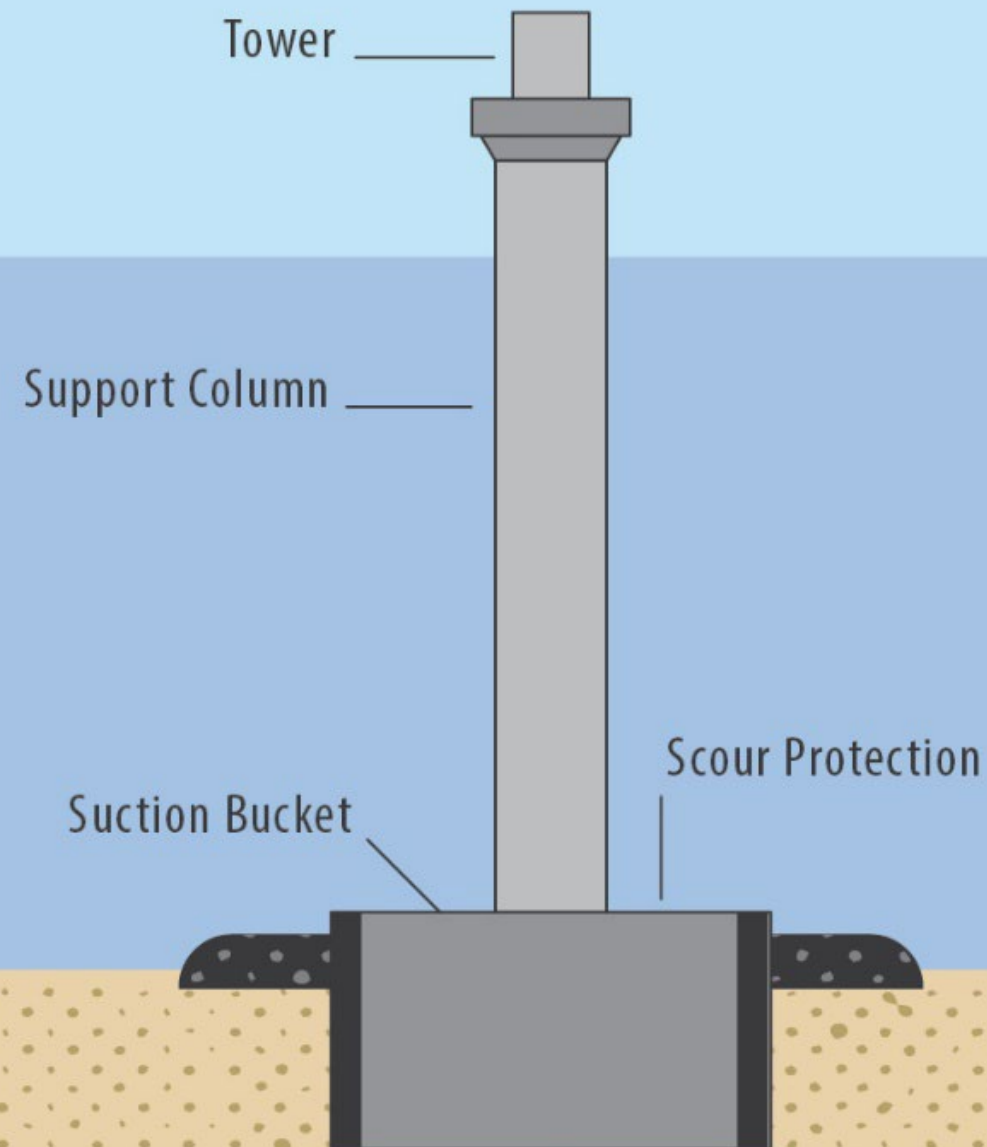

Description

- In its simplest form, a suction bucket foundation is a cylinder with an open bottom and a closed top.

Installation

- Lowered to the seabed through controlled flooding until the suction bucket begins to penetrate the seabed
- Subsea pumps create a pressure differential by pumping water out of the suction bucket and forcing it deeper into the seabed.

Acoustic Effects

- Less effects than monopiles due to less noise inducing activities during installation.

Gravity Foundations

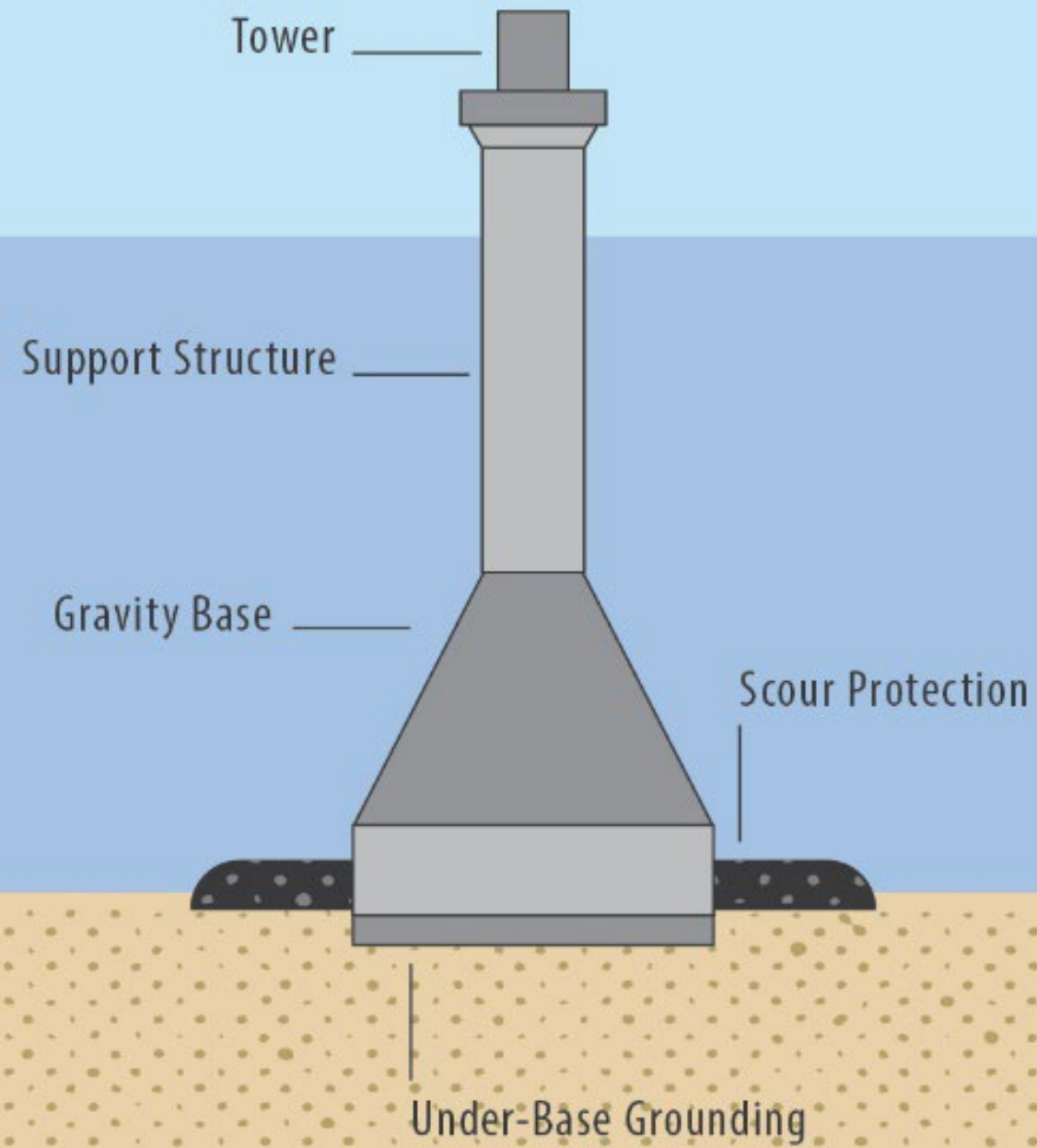

Description

- Gravity foundations, also known as gravity based structures (GBS), are structures with wide, heavy bases that sit on the seafloor and support the cylindrical central column.
- Most commonly made of reinforced concrete, but steel designs are also used.

Installation

- Often require seabed preparation to create a flat and level area for the base.
- Seabed preparation may involve dredging or the buildup of a level gravel pad.

Acoustic Effects

- Less intense effects than pile driving but seabed preparation requires much more time.

Floating Foundations

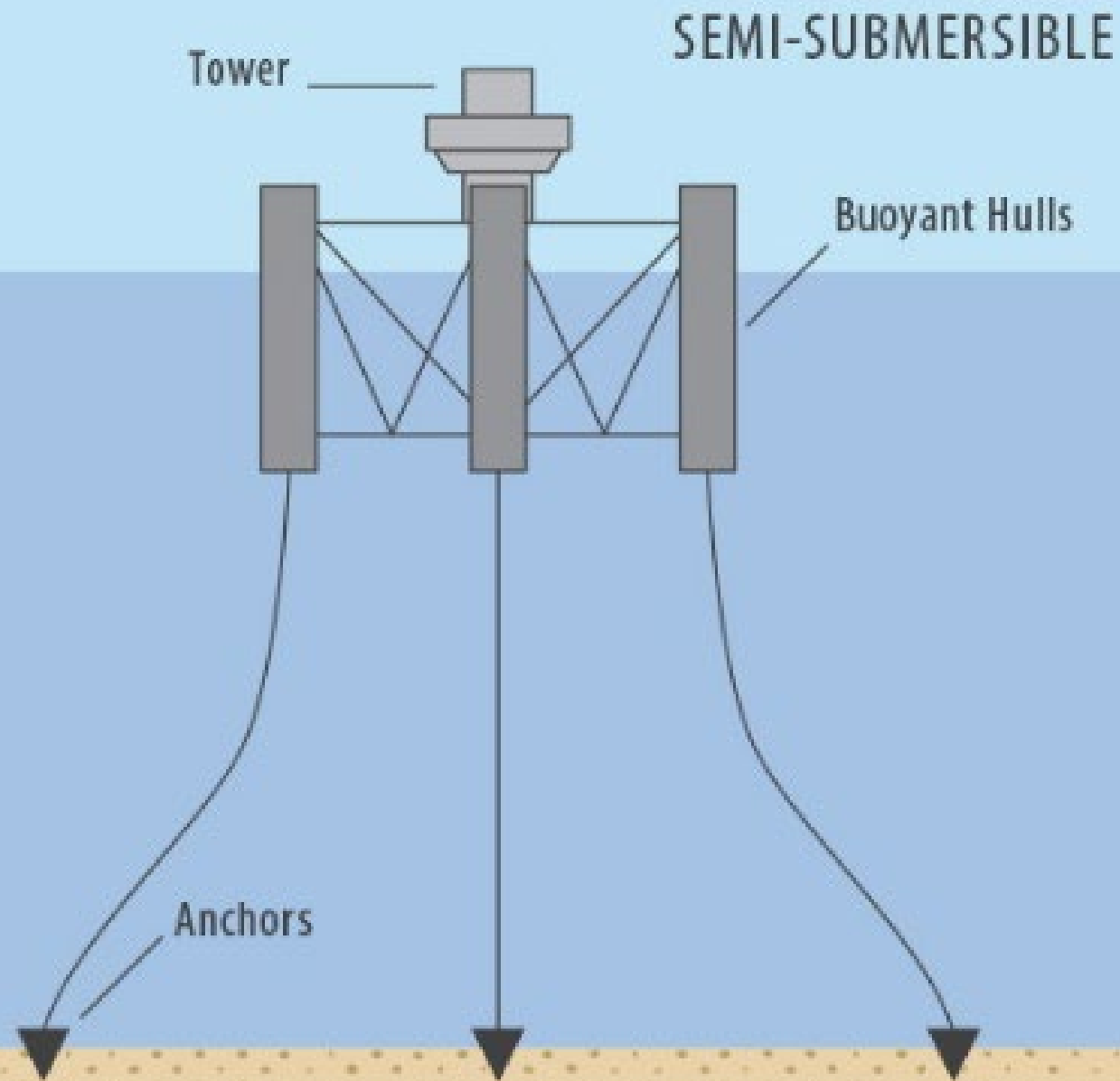

Semi-submersible

Description

- Made of multiple hulls or submerged columns connected by braces with sufficient buoyancy to cause the structure to float and resist overturning

Installation

- An anchoring system is required primarily for station keeping.
- Anchors may be deadweight anchors, drag anchors, dynamically embedded anchors, driven piles, or suction caissons.

Acoustic Effects

- Smaller effects than monopiles if installed by piling (much smaller piles); less effects if installed by deadweight anchors, drag anchors, dynamically embedded anchors, or suction caissons.

Floating Foundations

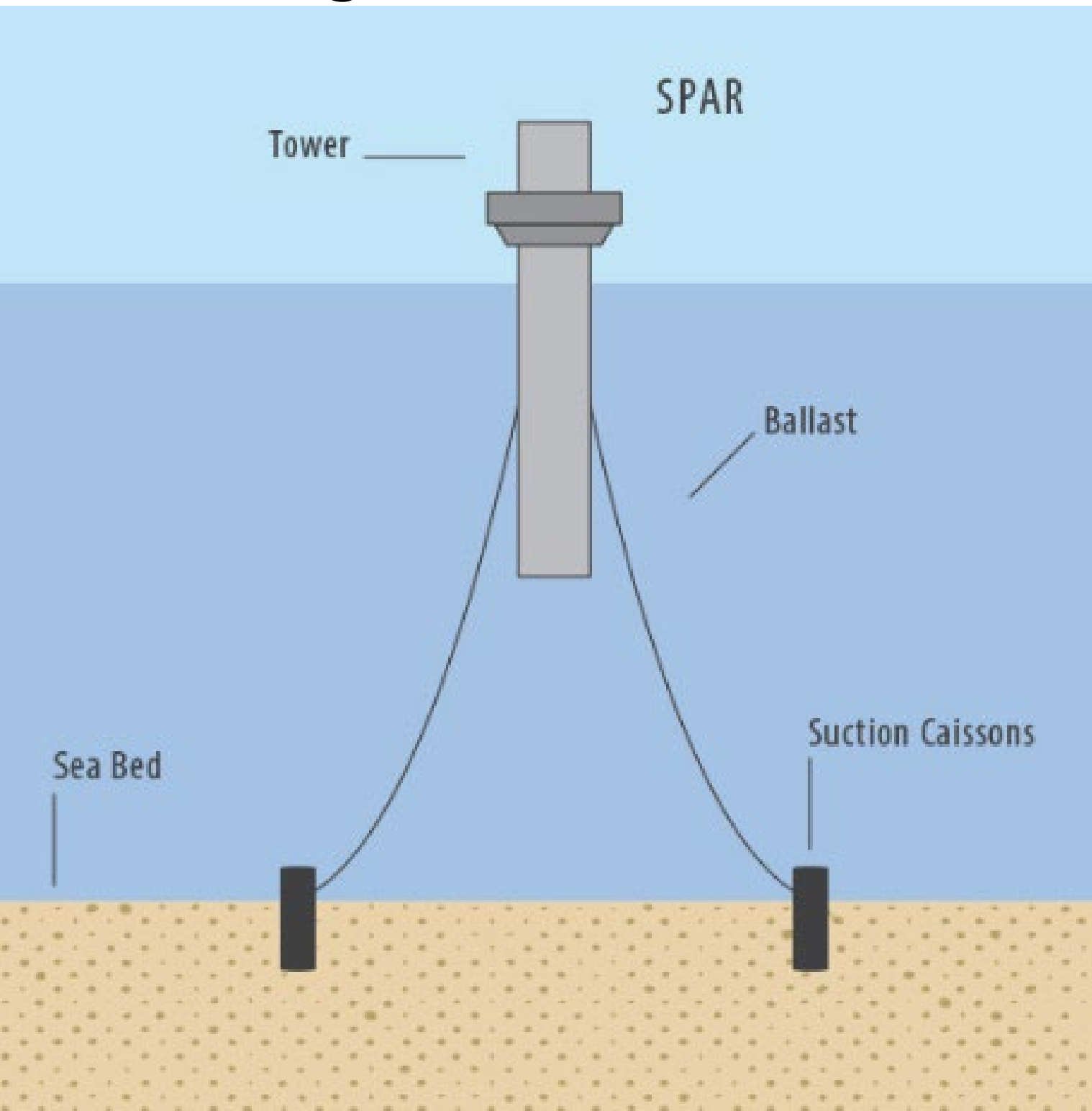

Spar (or Spar Buoy)

Description

- Spars have a single ballasted cylinder that supports the tower and extends well below the waterline.

Installation

- An anchoring system is required primarily for station keeping.
- Anchors may be deadweight anchors, drag anchors, dynamically embedded anchors, driven piles, or suction caissons.

Acoustic Effects

- Smaller effects than monopiles if installed by piling (much smaller piles); less effects if installed by deadweight anchors, drag anchors, dynamically embedded anchors, or suction caissons.

Floating Foundations

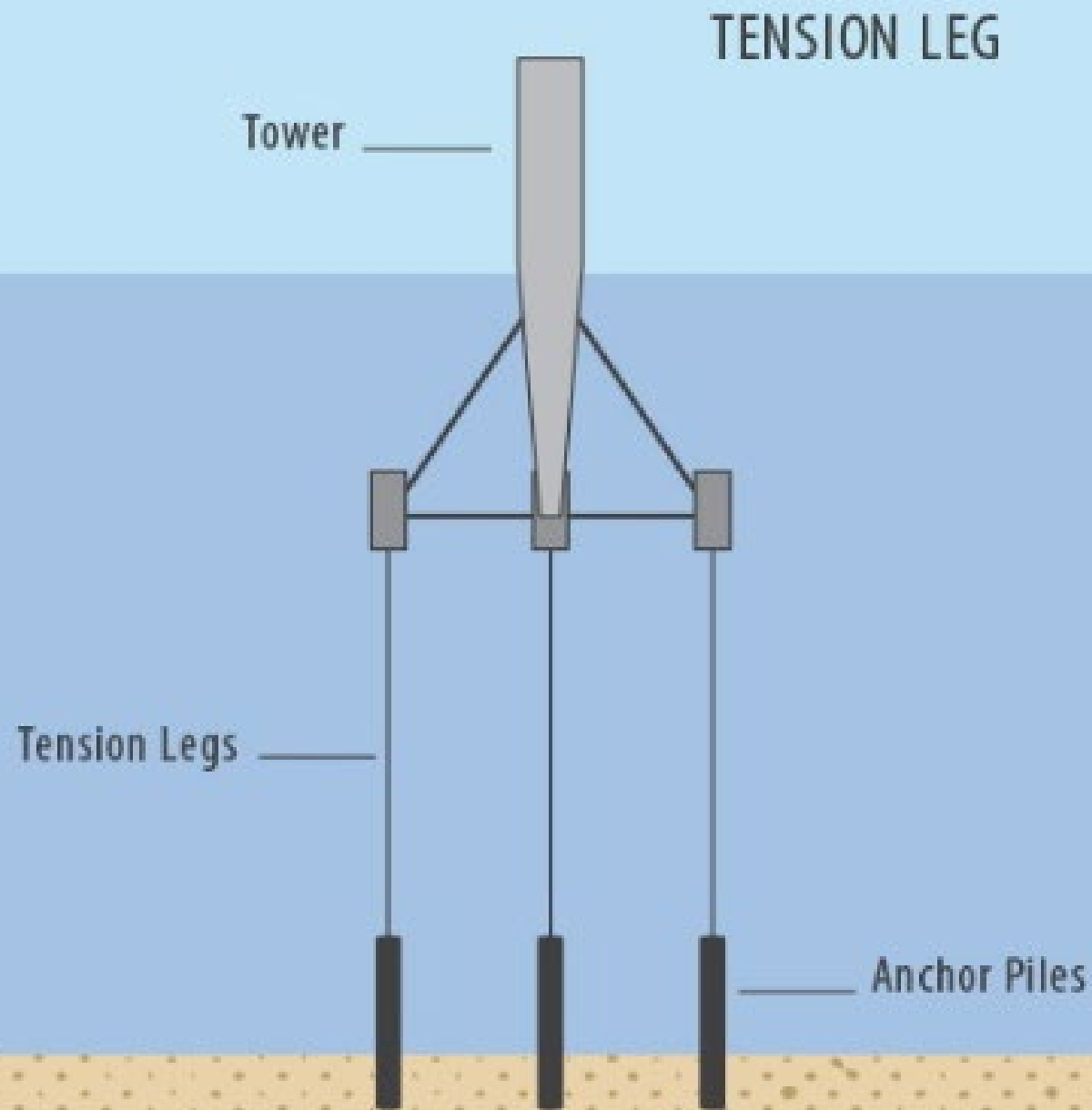

Tension Leg Platform (TLP)

Description

- TLPs are buoyant multihull steel floating platforms.
- Moored to the seafloor by vertical tendons or tension legs to minimize vertical movement of the structure

Installation

- Most often anchored with piles or suction caissons for their greater and more reliable pullout resistance, compared to other anchors.

Acoustic Effects

- Smaller effects than monopile if installed by piling (much smaller piles)
- Suction caissons cause minimal acoustic effects, relative to impact pile driving.

For More Information

OCS Study
BOEM 2021-053

Comparison of Environmental Effects from Different Offshore Wind Turbine Foundations

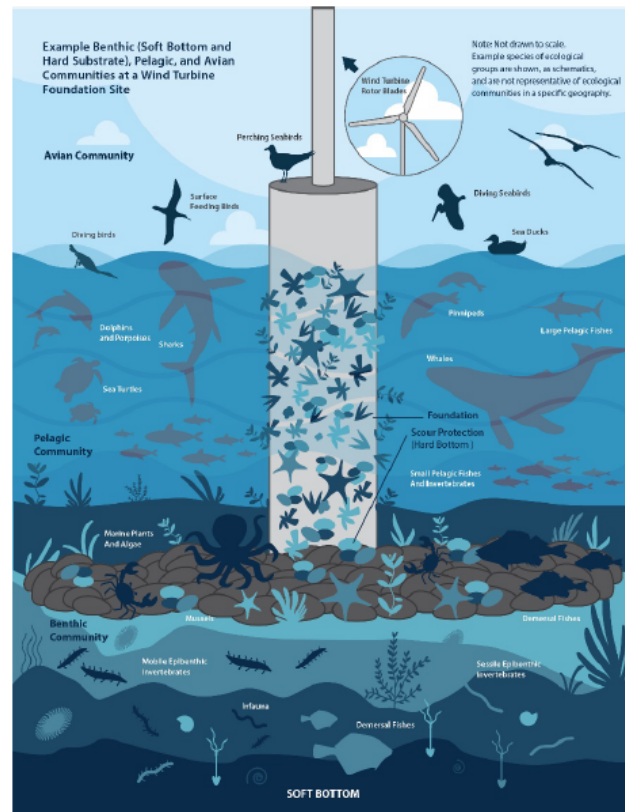

U.S. Department of the Interior
Bureau of Ocean Energy Management
Office of Renewable Energy Programs

BOEM
BUREAU OF OCEAN ENERGY MANAGEMENT



<https://www.boem.gov/sites/default/files/documents/environment/Comparison-Environmental-Effects-Different-OWT-Foundations-2021.pdf>





Get in touch with us:
Ralph Grismala, P.E.

Civil and Environmental Engineer
+1 (860)886-3788
Ralph.Grismala@icf.com

icf.com

 [linkedin.com/company/icf-international/](https://www.linkedin.com/company/icf-international/)

 twitter.com/icf

 <https://www.facebook.com/ThisIsICF/>
