

U.S. DEPARTMENT OF
ENERGY

Office of
ENERGY EFFICIENCY &
RENEWABLE ENERGY

**IOWA STATE
UNIVERSITY**

Passive Ultrasonic Deterrents to Reduce Bat Mortality in Wind Farms

Anupam Sharma

Iowa State University



Project Overview

Idea/Technology:

- Blade-mounted ultrasonic deterrent driven by blade-relative flow

Technology Impact:

- Mitigate bat mortality at wind farms with little-to-no reduction in energy capture
- Cost savings by replacing *operational mitigation* with the proposed deterrent

Project Goals:

- Develop a passive, blade-mounted ultrasonic bat deterrent
- Characterize ultrasound generation in anechoic chamber & aero performance in wind tunnel

Concept and Technical Merit

- Adaptation of dog (Galton's) whistle
- Working principle:
 - flow instability coupled with a resonator → high-intensity sound
- Multiple resonators for broad spectral coverage (20 - 50 kHz)
- Blade-relative air flow for passive operation
 - no moving parts → less possibility of mechanical failure
- Blade-mounted ultrasonic deterrents need to radiate smaller distance (~5-10 m);
 - Nacelle/tower-mounting requires coverage of the entire rotor disk (50-100 m)

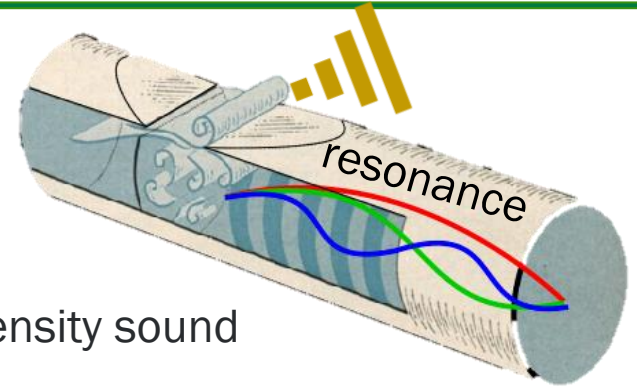

Research Plan

- Design the deterrent device and characterize its acoustics in lab tests
- Design optimization to produce the desired ultrasound spectra with minimum pressure and flow rate
 - Acoustic characterization in the anechoic chamber
- “Intake” design to mount the deterrent on rotor blades
 - Identify mounting locations on rotor blades
 - Design intakes to supply airflow to the deterrent
- Characterize the aerodynamic performance and aeroacoustics of the deterrent mounted on a rotor blade section
 - Aero/acoustics performance characterization of a blade section with the deterrent
 - Iterate on deterrent design based on performance results
- **Biological efficacy will need to be assessed in the future ... not part of this project**

1) Acoustic characterization in anechoic chamber

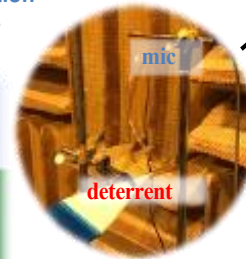

- Verify ultrasound generation in ISU anechoic room
- Single mic (B&K 4135) measurements
- Pressurized air to drive deterrent

2) Passive ultrasound generation and aero performance test in a wind tunnel

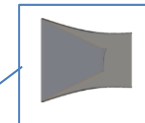
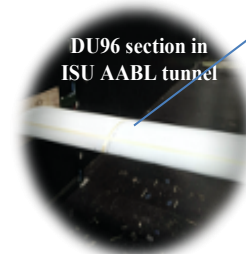
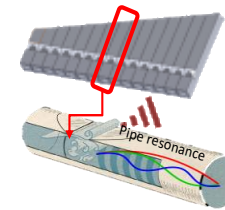

zoom view of deterrent w/ intake nozzle

- Wind tunnel test w/ deterrent mounted
- Measure ultrasound (passive generation ability) and wake profiles (aero impact)

Project Timeline

Research Task	Q4 '19	Q1 '20	Q2 '20	Q3 '20	Q4 '20	Q1 '21	Q2 '21	Q3 '21	Q4 '21
<i>Development of the deterrent device</i>									
Initial prototype and its acoustic characterization									
Design optimization & verification of the optimized design									
<i>Design of intake to mount the deterrent</i>									
Identify blade mounting locations									
Develop inlet designs for airflow									
<i>Lab testing of the deterrent mounted on a blade section</i>									
Aero performance characterization									
Design iterations									
Acoustic characterization of the optimized design									
<i>Project reporting and publication</i>									

Key Dates:

- Development of the deterrent device (initial design) Q3 '20
- Intake design + blade mounting ideas Q1 '21
- Lab testing of the deterrent mounted on a blade section Q3 '21
- Project reporting Q4 '21

Preliminary Results

- Whistle fabrication & testing
 - Initial whistle design ideas ready and lab setup prepared for testing
 - Derivative of the design by Beeken (1969)*
 - 3D printing (for fabrication) has been evaluated → works well

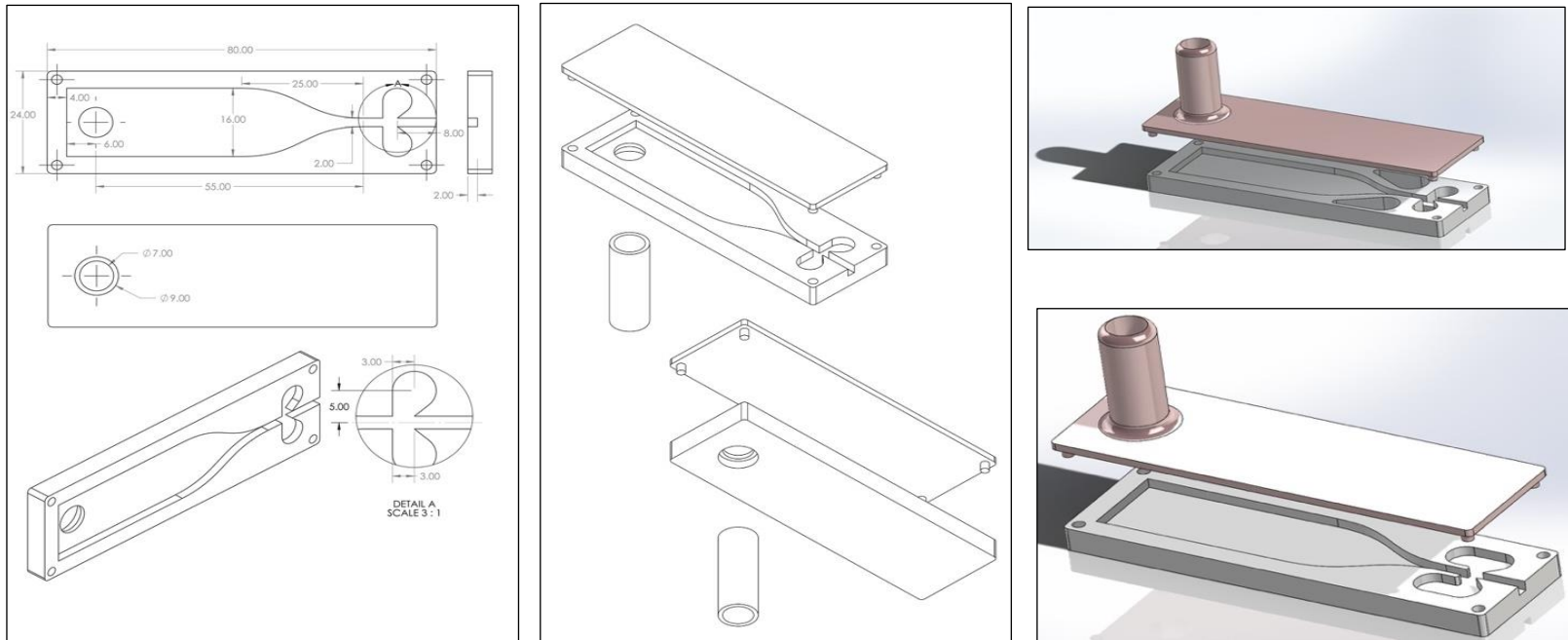

Figure: A CAD design of the fluid ultrasonic generator.

* Beeken (1969) "Fluid Ultrasonic Generator" US patent #3432804

Preliminary Results

- Preliminary acoustic characterization → verified ability to produce ultrasound tones
- Variations of the design for generating multiple tones to cover a broad ultrasound frequency range being evaluated

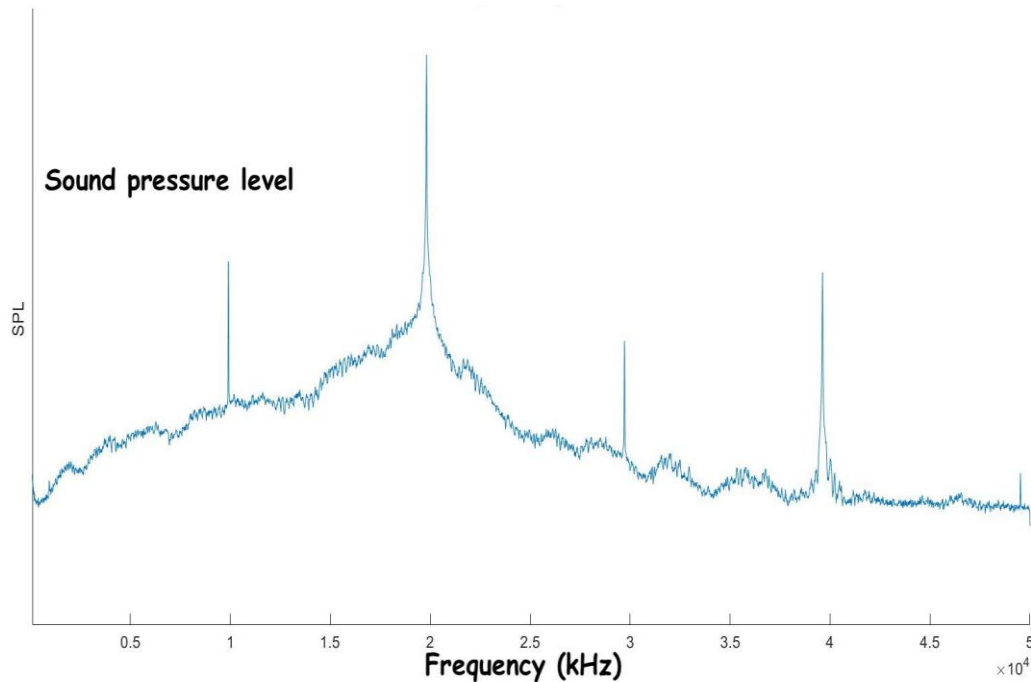

Figure: Preliminary acoustic measurements for the first prototype of the ultrasonic whistle - single resonator



Figure: design variations to cover a large ultrasound frequency range

Acknowledgement

Acknowledgement

This material is based upon work supported by the U.S. Department of Energy's Office of Energy Efficiency and Renewable Energy (EERE) under the Wind Energy Technology Office Award Number DE-EE0008731

Disclaimer

This report was prepared as an account of work sponsored by an agency of the United States Government. Neither the United States Government nor any agency thereof, nor any of their employees, makes any warranty, express or implied, or assumes any legal liability or responsibility for the accuracy, completeness, or usefulness of any information, apparatus, product, or process disclosed, or represents that its use would not infringe privately owned rights. Reference herein to any specific commercial product, process, or service by trade name, trademark, manufacturer, or otherwise does not necessarily constitute or imply its endorsement, recommendation, or favoring by the United States Government or any agency thereof. The views and opinions of authors expressed herein do not necessarily state or reflect those of the United States Government or any agency thereof.

