

# Development of an Adaptable Monitoring Package for Marine Renewable Energy Projects

Brian Polagye and James Joslin

Northwest National Marine Renewable Energy Center

Andy Stewart

Applied Physics Laboratory

University of Washington

Developments in Research on Environmental Effects

April 9, 2013



# Motivation for Environmental Research

**Satisfy Resource Agency Mandates**



**Identify Commercial-Scale Impacts**



**Pre-empt Impacts by Design**



# Priority Areas for Pilot-Scale Monitoring

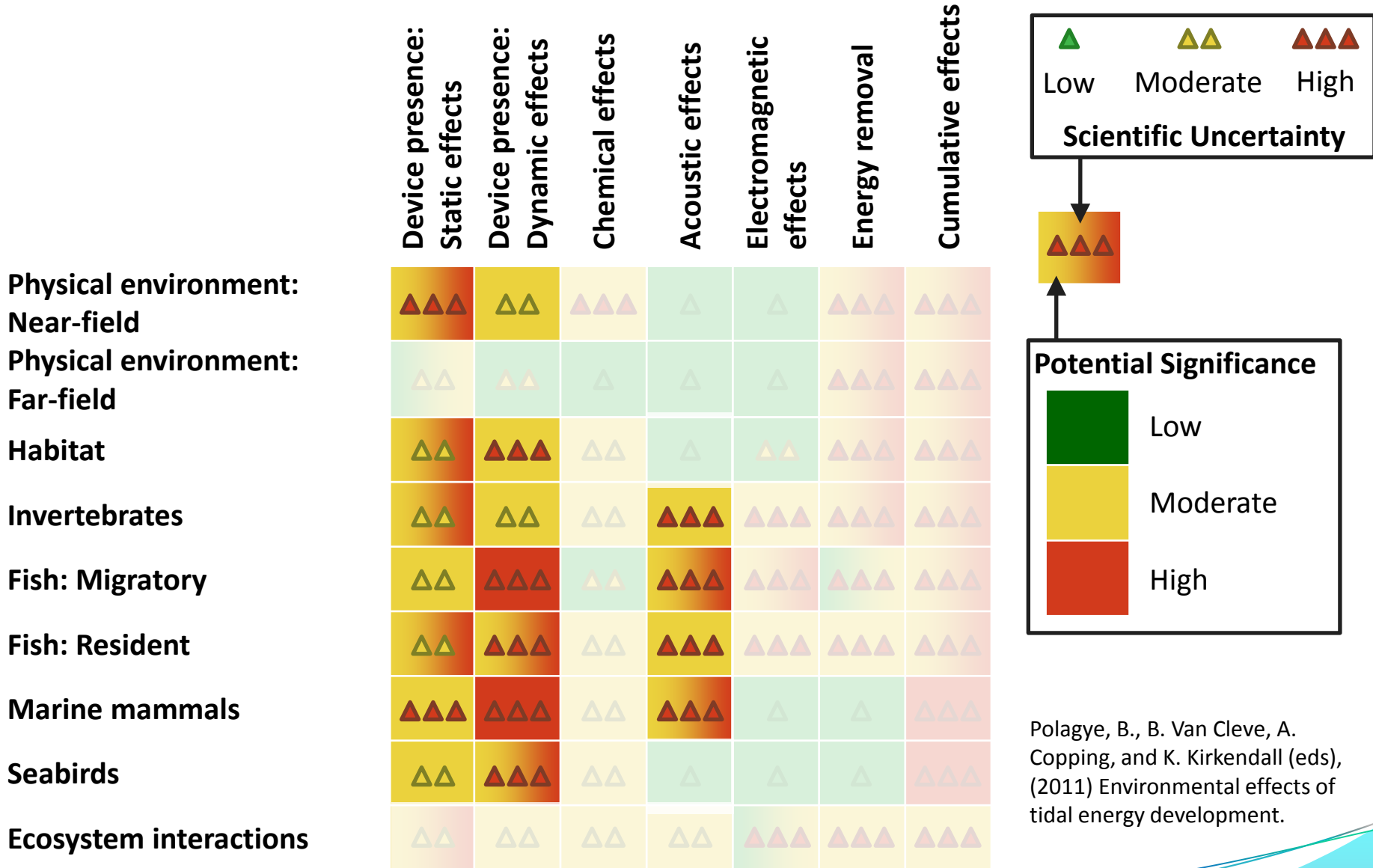

Polagye, B., B. Van Cleve, A. Copping, and K. Kirkendall (eds), (2011) Environmental effects of tidal energy development.



# Capabilities: Stereo Optical Tracking

Joslin, J., B. Polagye, and S. Parker-Stetter (*in prep*)  
Development of a Hybrid Optical-Acoustical Camera System for Monitoring Hydrokinetic Turbines.

Left Camera Image



Right Camera Image

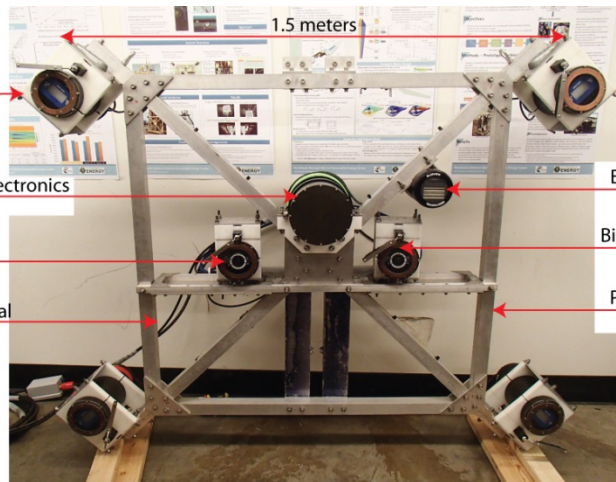

3 Dimensional Target Triangulation

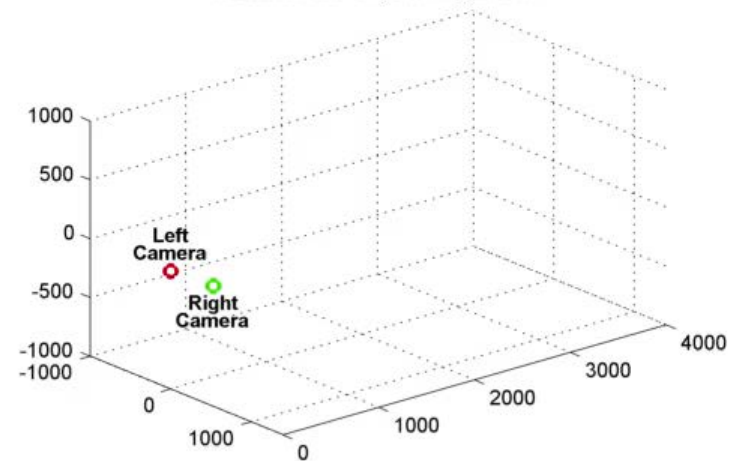

# Capabilities: Endurance Test Imagery

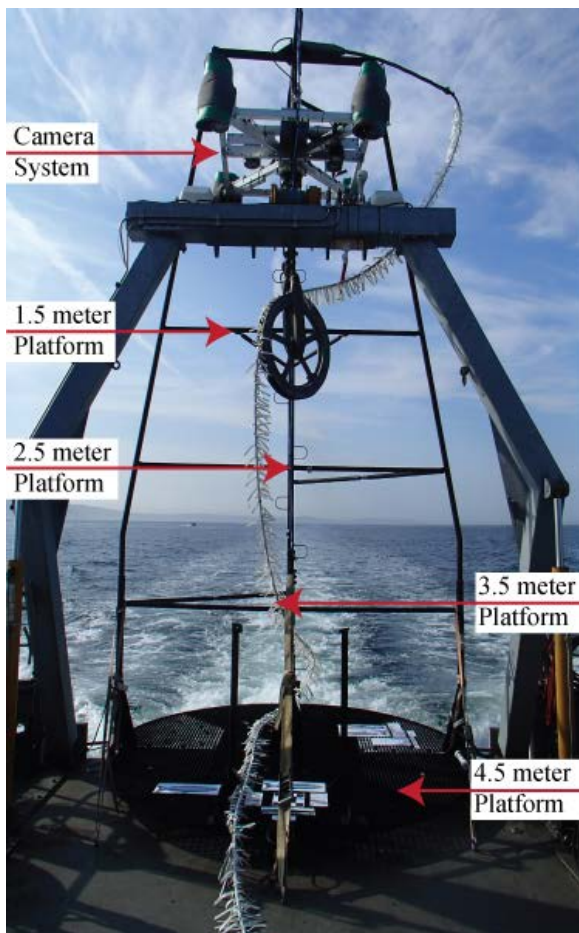

# Challenge: Power and Data Requirements

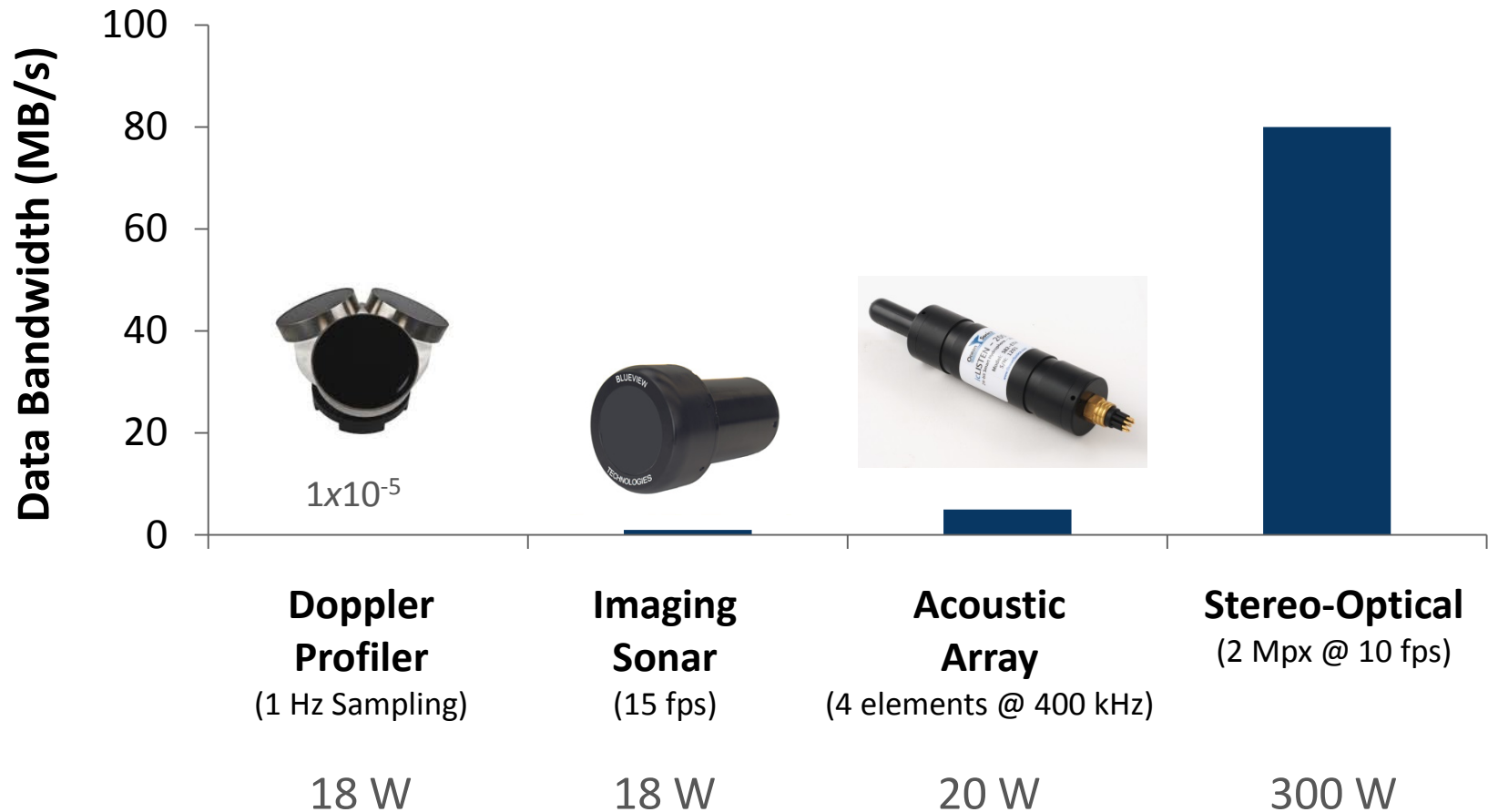

# “Solution”: Cabled Monitoring Packages

- Export cables for marine renewable energy converters often have auxiliary power and communications channels
- Ability to leverage infrastructure from ocean observing initiatives

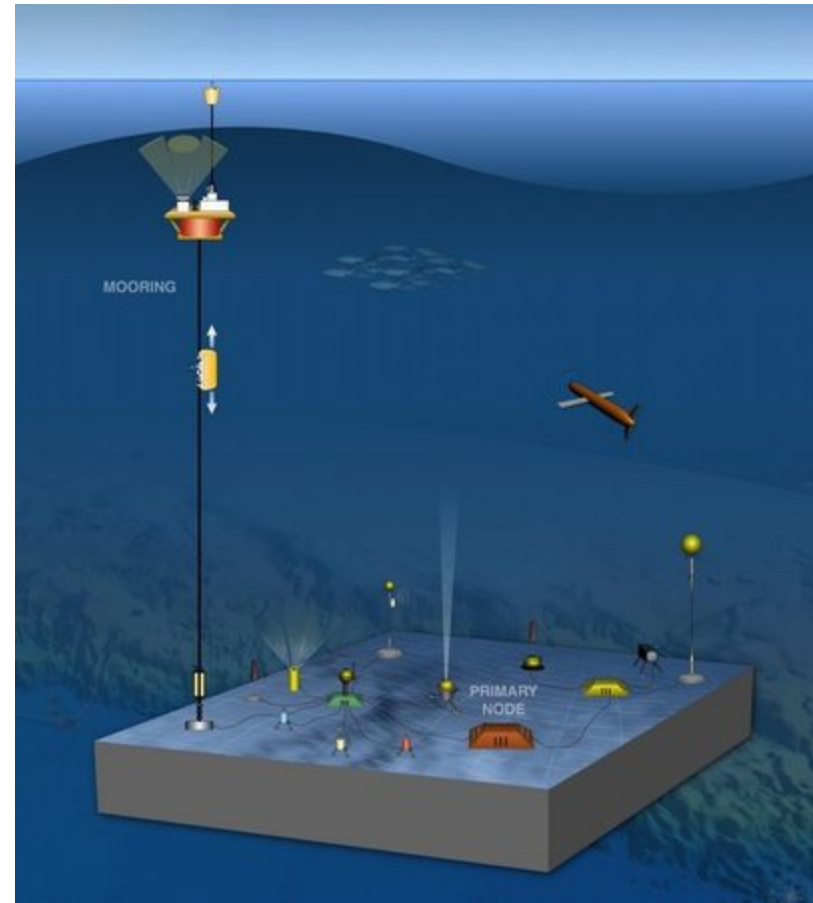

*Regional Scale Nodes*

# Challenges to Cabled Monitoring at Marine Renewable Energy Projects

## Data Volumes

*Easy to generate 100's of TB of data*



**Well-Posed  
Hypothesis Testing**

*Project-Specific*

## Adaptive Monitoring

*Need to be able to physically reconfigure instruments*



**Enabling  
Infrastructure**

*Generalized*





# Design Specifications / Wish List

- High power (kW) and data bandwidth (Gbps) for instrumentation
- Recover and redeploy in harsh environments (without the use of divers or heavy work-class ROVs)
- Do not disturb the marine renewable energy device being observed
- Achieve all of the above at low cost



# Adaptable Monitoring Package

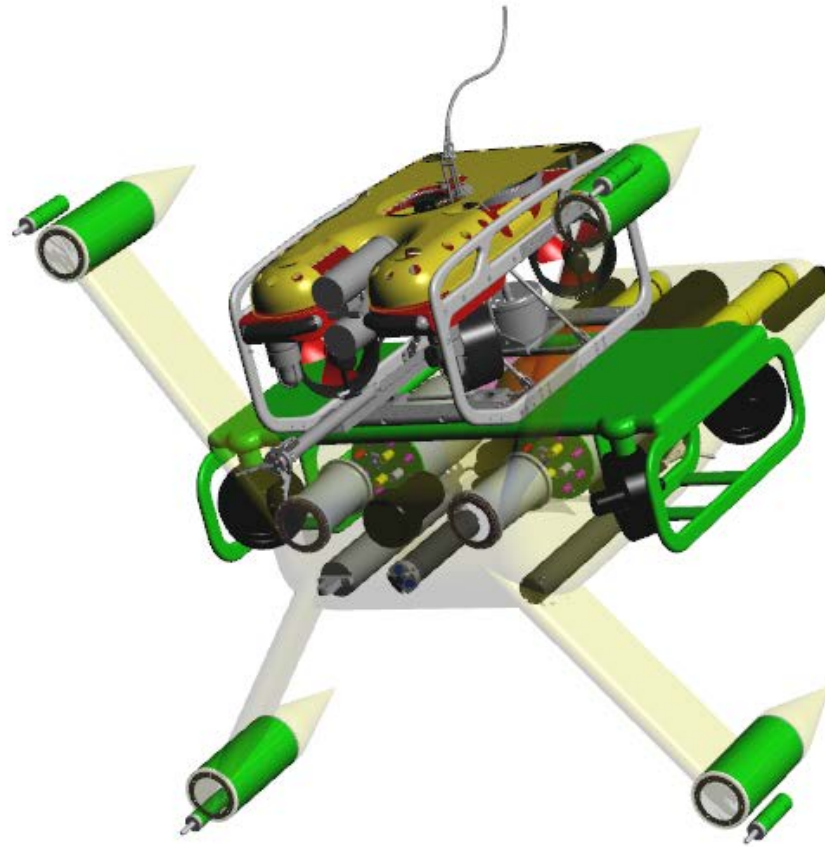

# Deployment Sequence

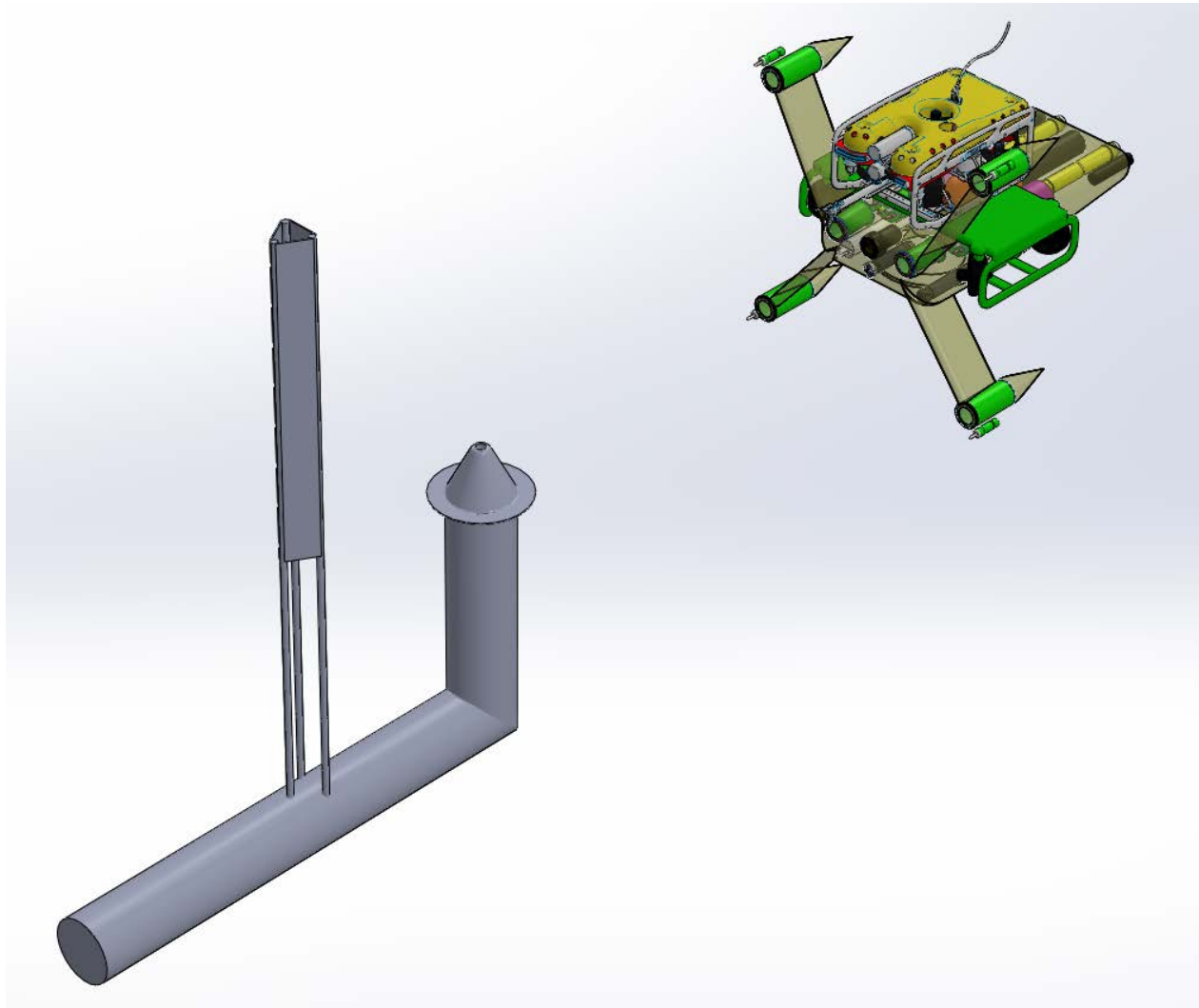

# Deployment Sequence

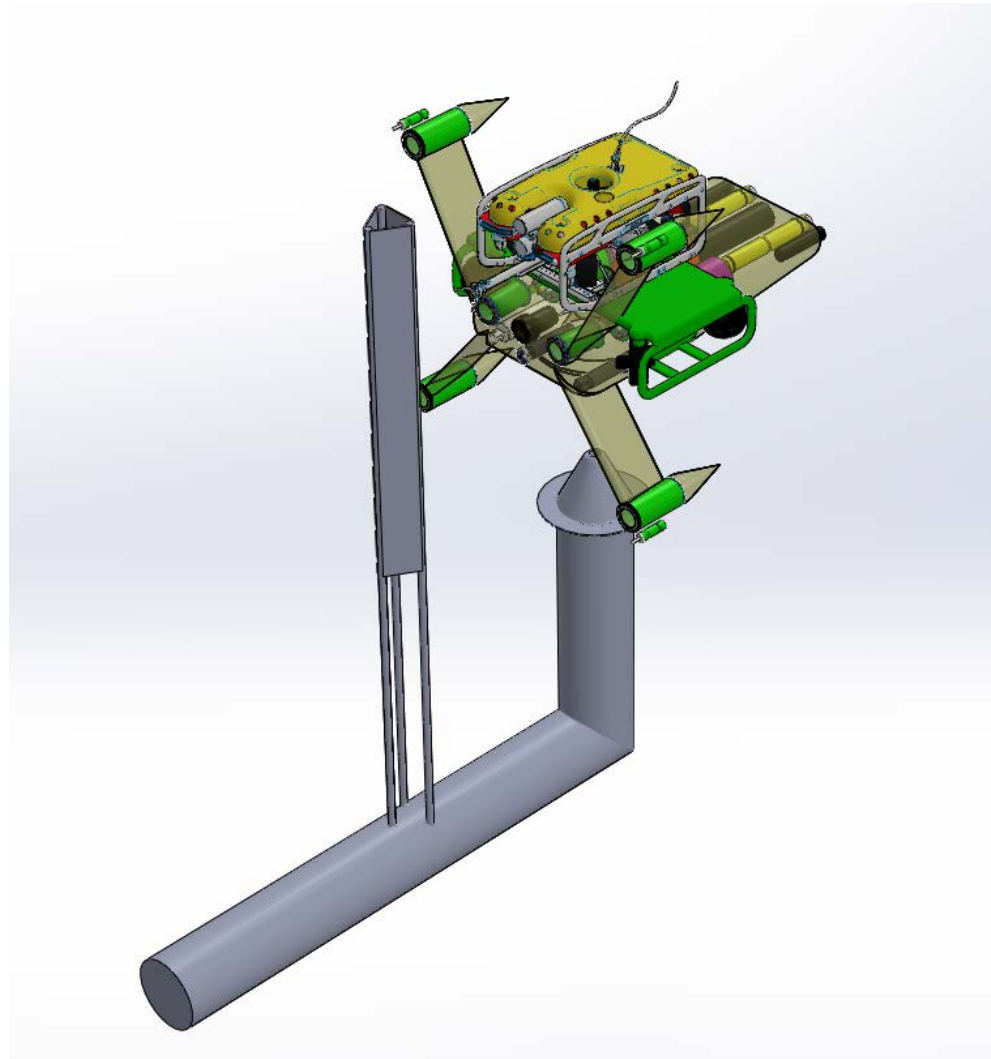

# Deployment Sequence

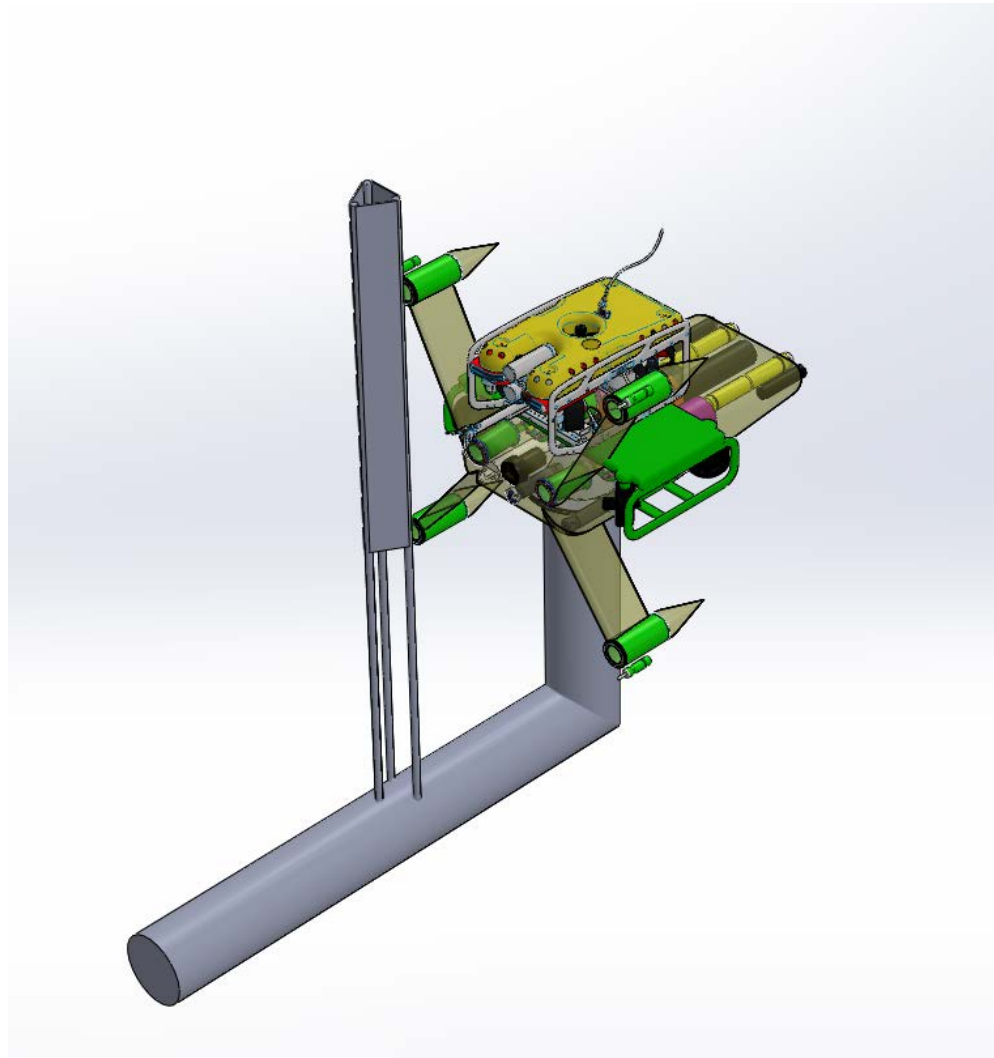

# Deployment Sequence

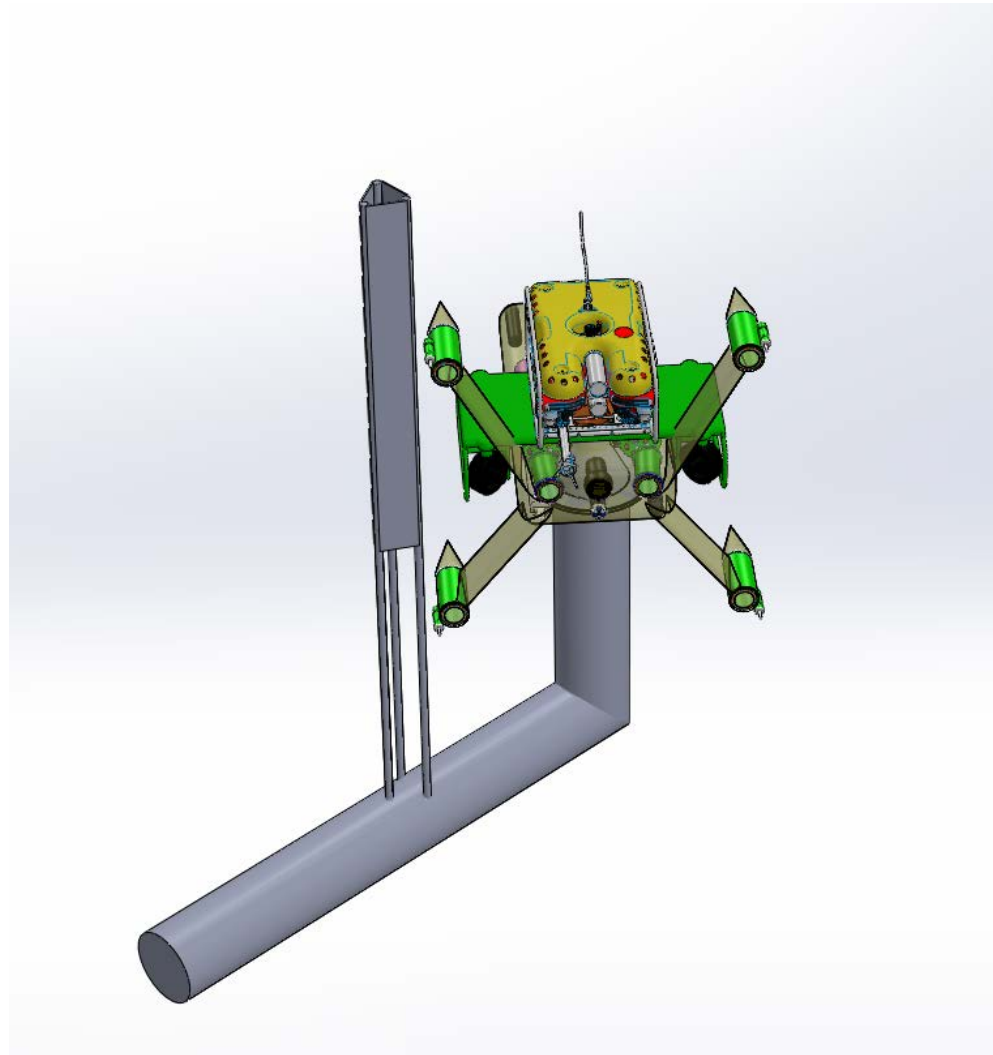

# Deployment Sequence

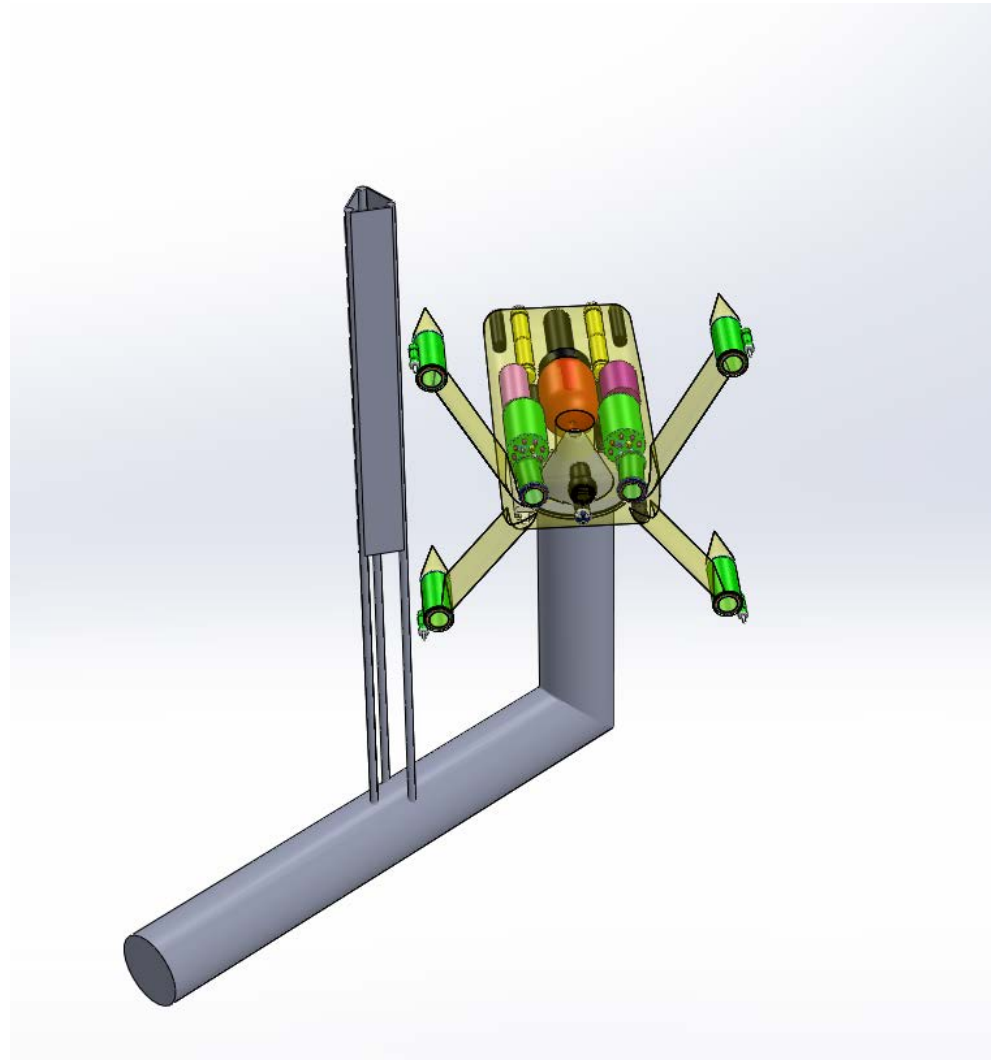

# Concept Strengths

- **Suitable for operation in high-energy wave and tidal environments**
- **Integrates with commercial-off-the-shelf inspection-class ROVs**
- **Single interface between monitoring instrumentation and marine renewable energy converters being studied**
- **All instrumentation recovered as a single, short operation from a common connection**





# Next Steps

- **Drag reduction studies**
- **Scale operations testing (tank)**
- **Full-scale operations testing (Puget Sound)**
- **Deployment as critical infrastructure for the Pacific Marine Energy Center**

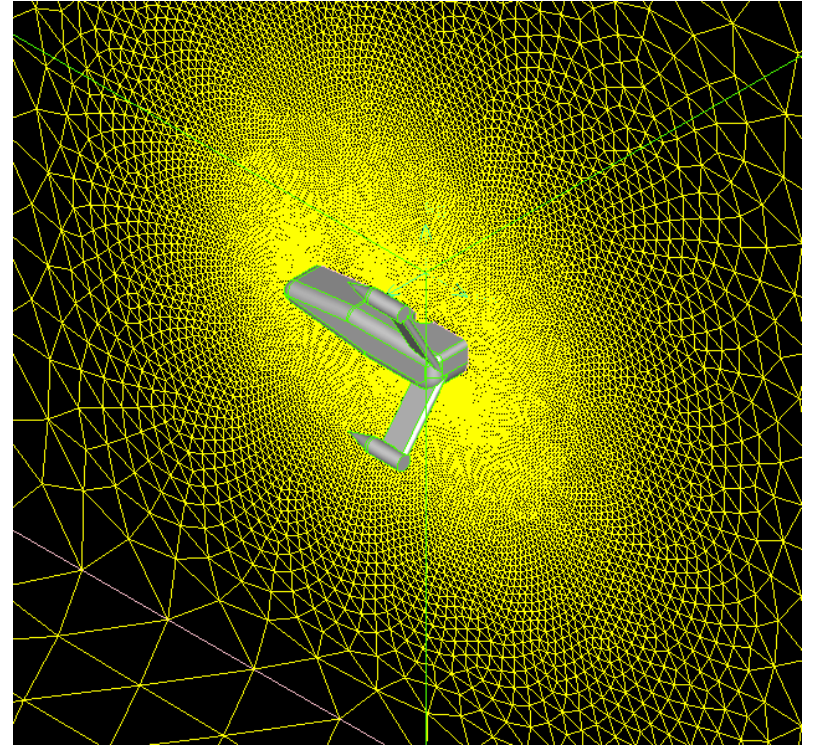

*CFD Mesh of AMP*

# Questions?



This material is based upon work supported by the Department of Energy under Award Number DE-FG36-08G018179.

