

Fish interaction with ORPC TidGen™ in Cobscook Bay

Gayle Zydlewski, University of Maine



Development of an ELAM Fish Behavior Model

Gayle Zydlewski, University of Maine

Mark Grippo, Argonne National Laboratory

Acknowledgments

- Zydlewski Lab
 - James McCleave
 - Haley Viehman
 - Garrett Staines
 - Jeffrey Vieser
 - Megan Altenritter
 - Haixue Shen
 - Matthew Altenritter
 - Matthew Dzaugis
 - Patrick Erbland
 - Brittney Fleenor
 - Alexander Jensen
 - Amy Wyman
- Chris Bartlett
- Fishermen and community partners.
- UMaine's Sustainability Solutions Initiative
- ORPC



Award EPS-0904155



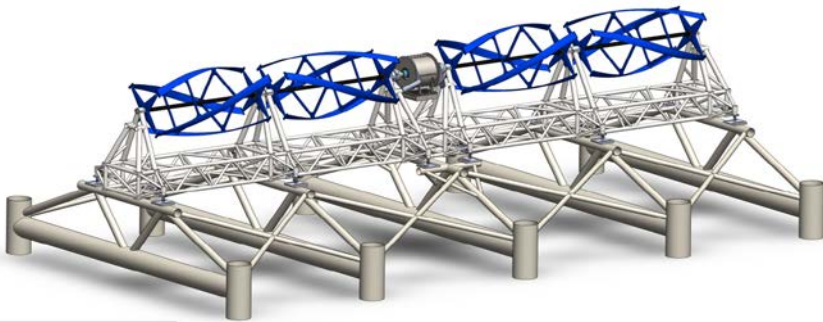
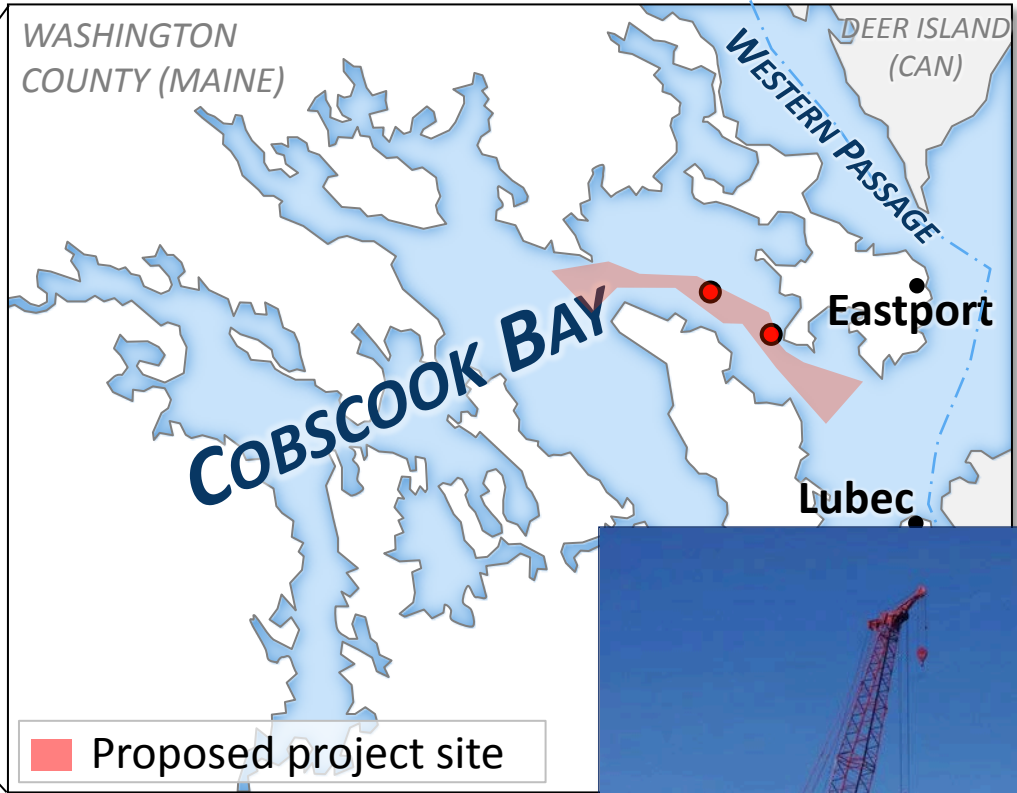
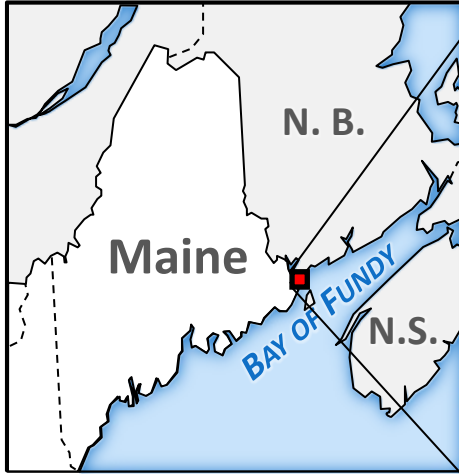

Broad scale changes
in distribution and abundance

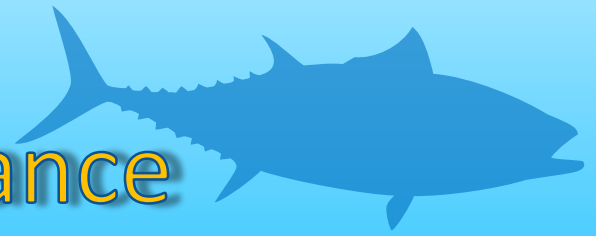

Individual evasion/avoidance

Individual interactions with blades

Individual evasion/avoidance

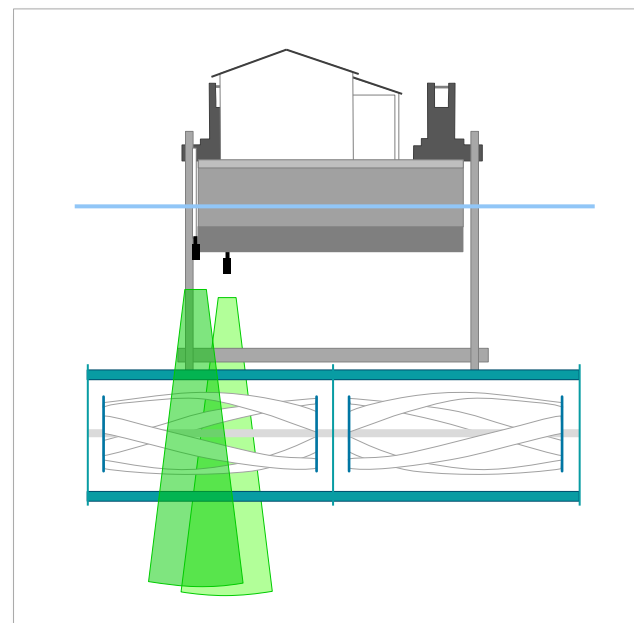
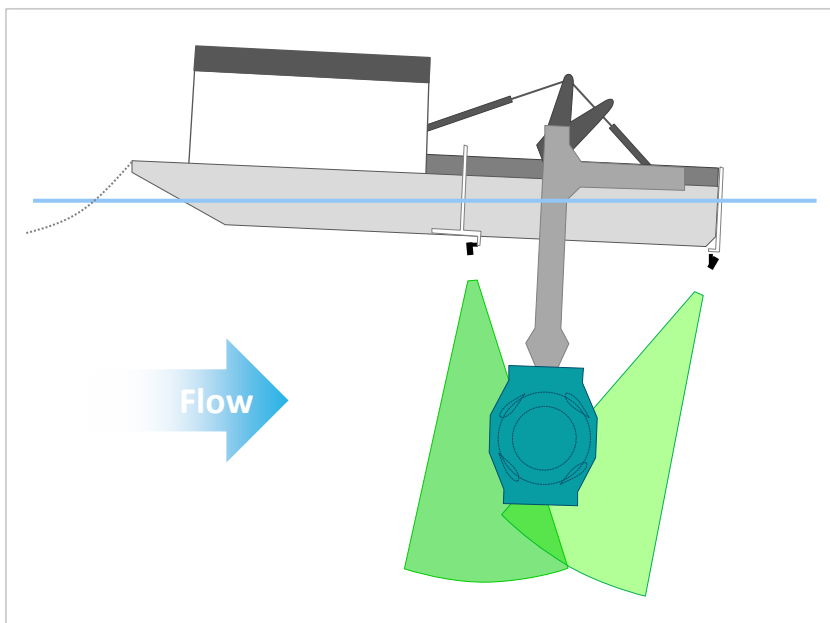
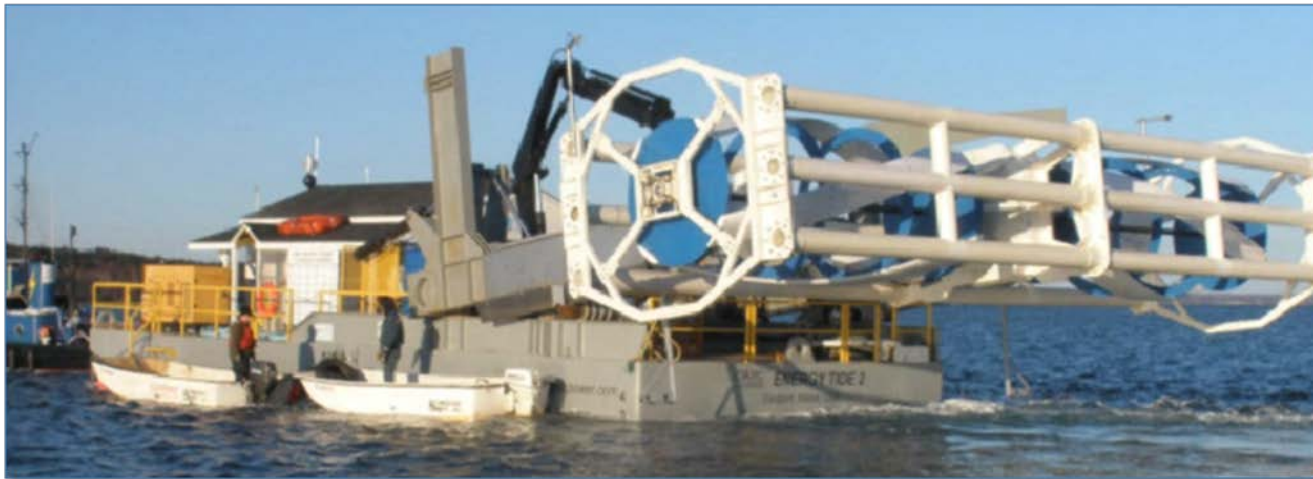

Example DIDSON Footage

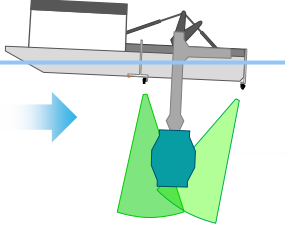

Upstream
(approach)

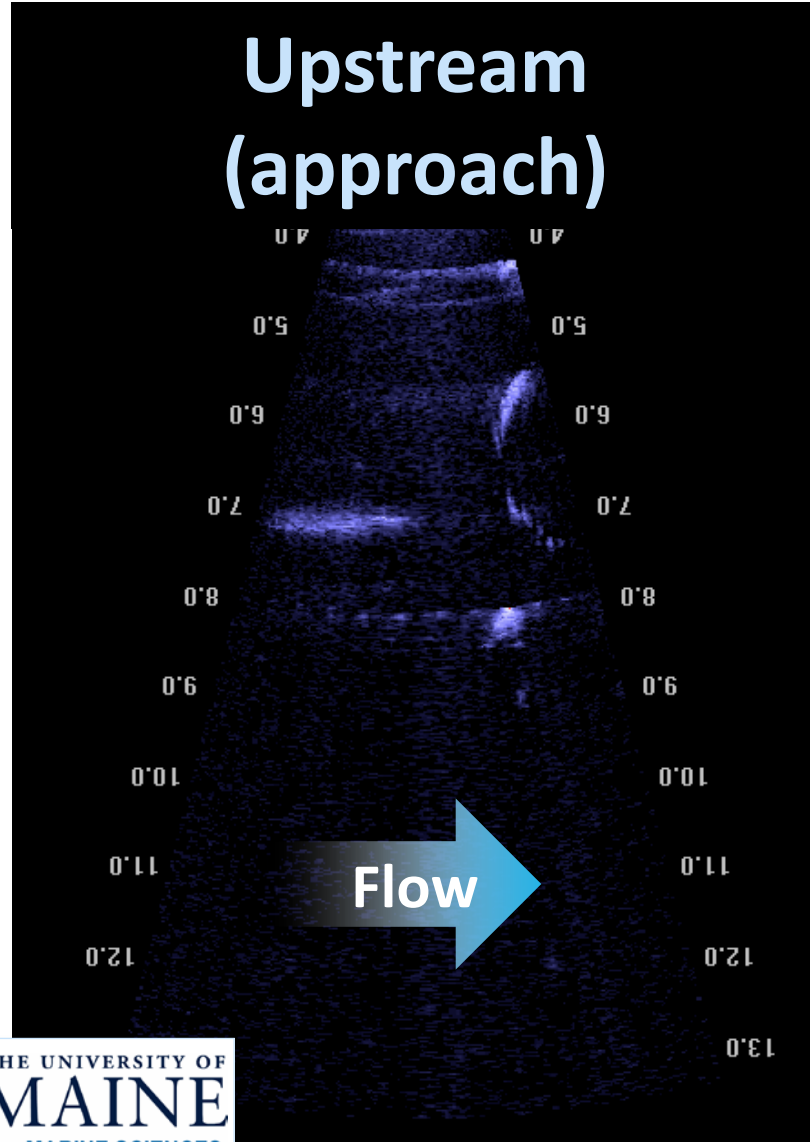

Downstream
(depart)

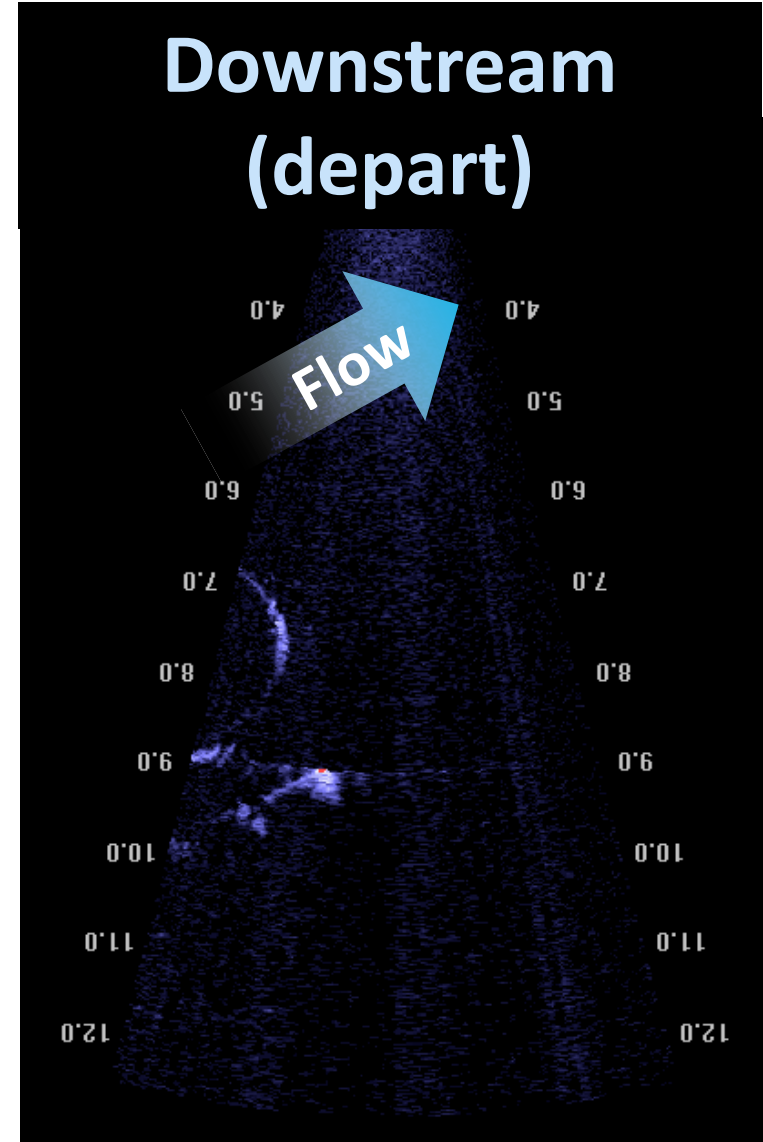

Individual Behavior

- Pass By

- Through Turbine:
 - Into Turbine
 - Out of turbine

- Active Avoidance:
 - Above
 - Reverse
 - Below

- In Wake

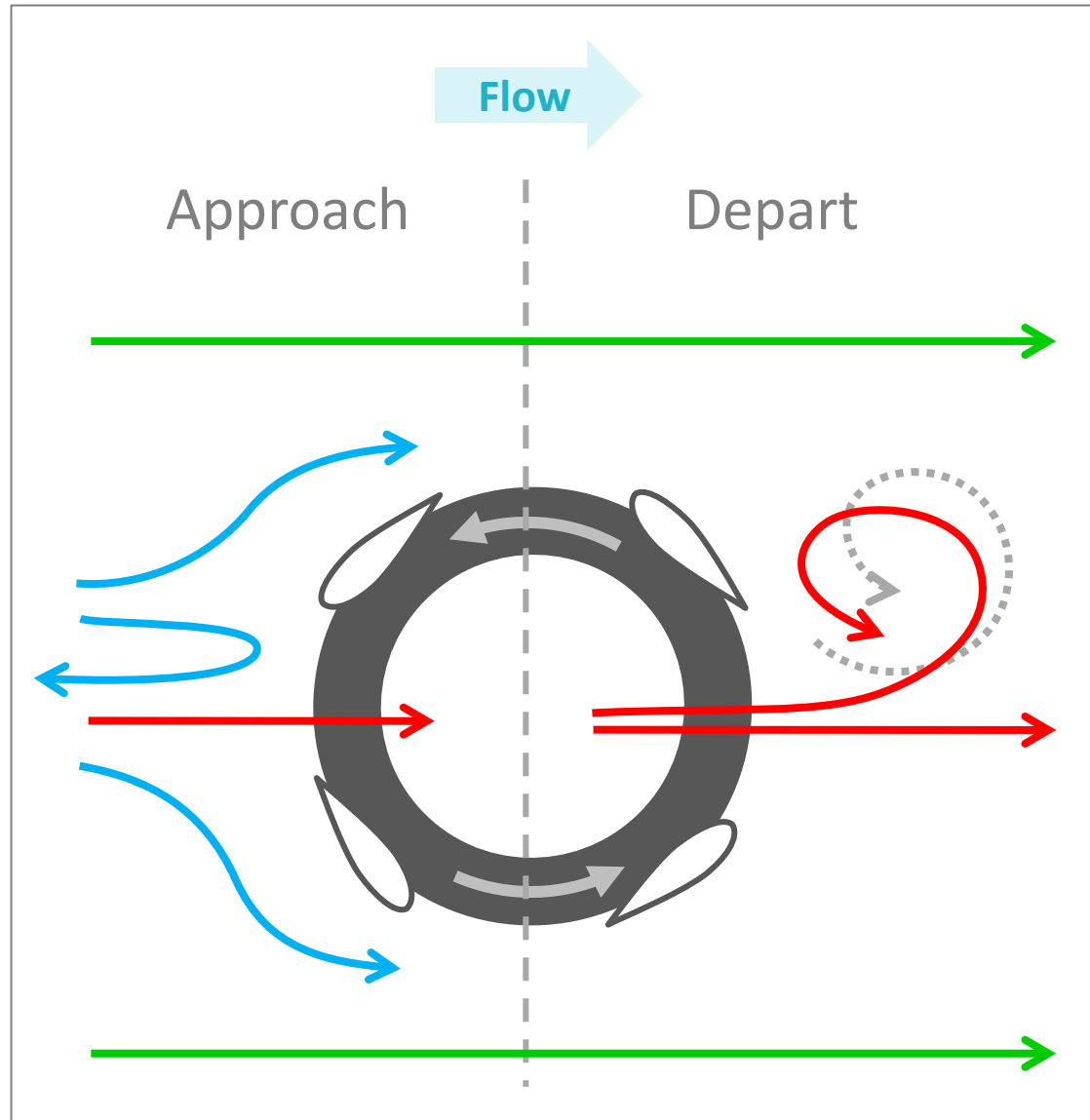

Viehman and Zydlewski. In revision. *Estuaries and Coasts*.

Behavior by Size, Day v. Night

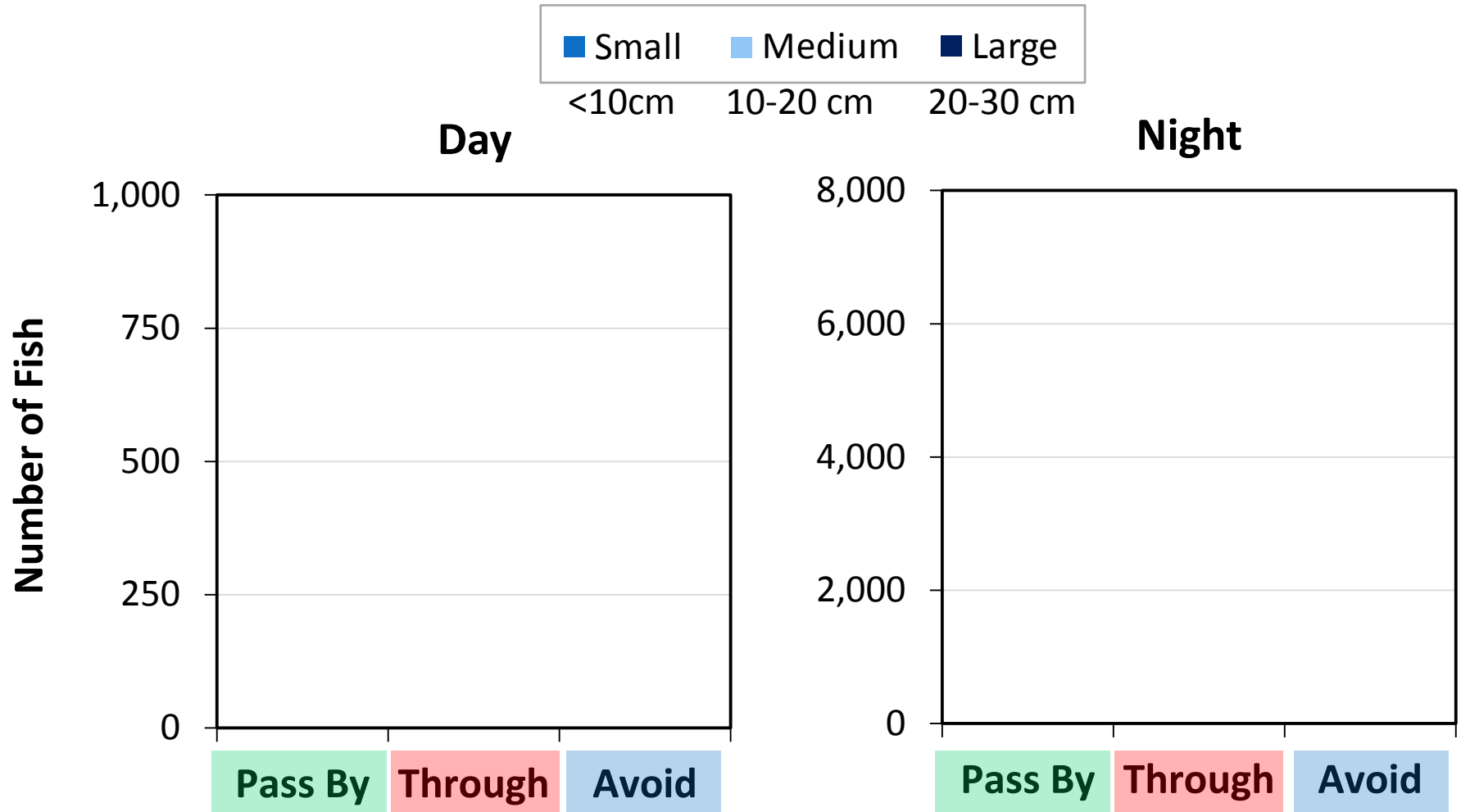

(when turbine is moving)

Viehman and Zydlewski. In revision. *Estuaries and Coasts*.



Individual evasion/avoidance

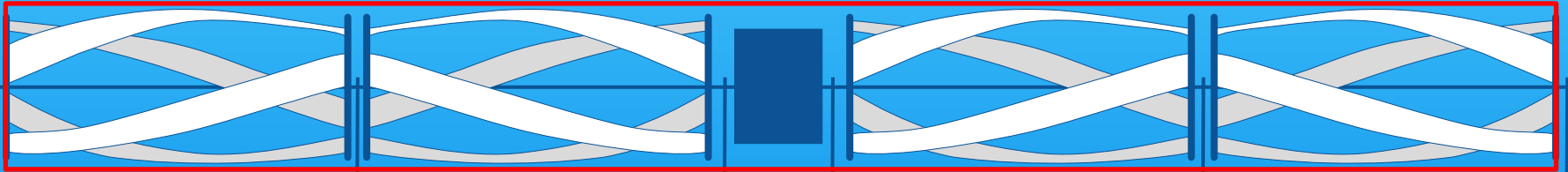

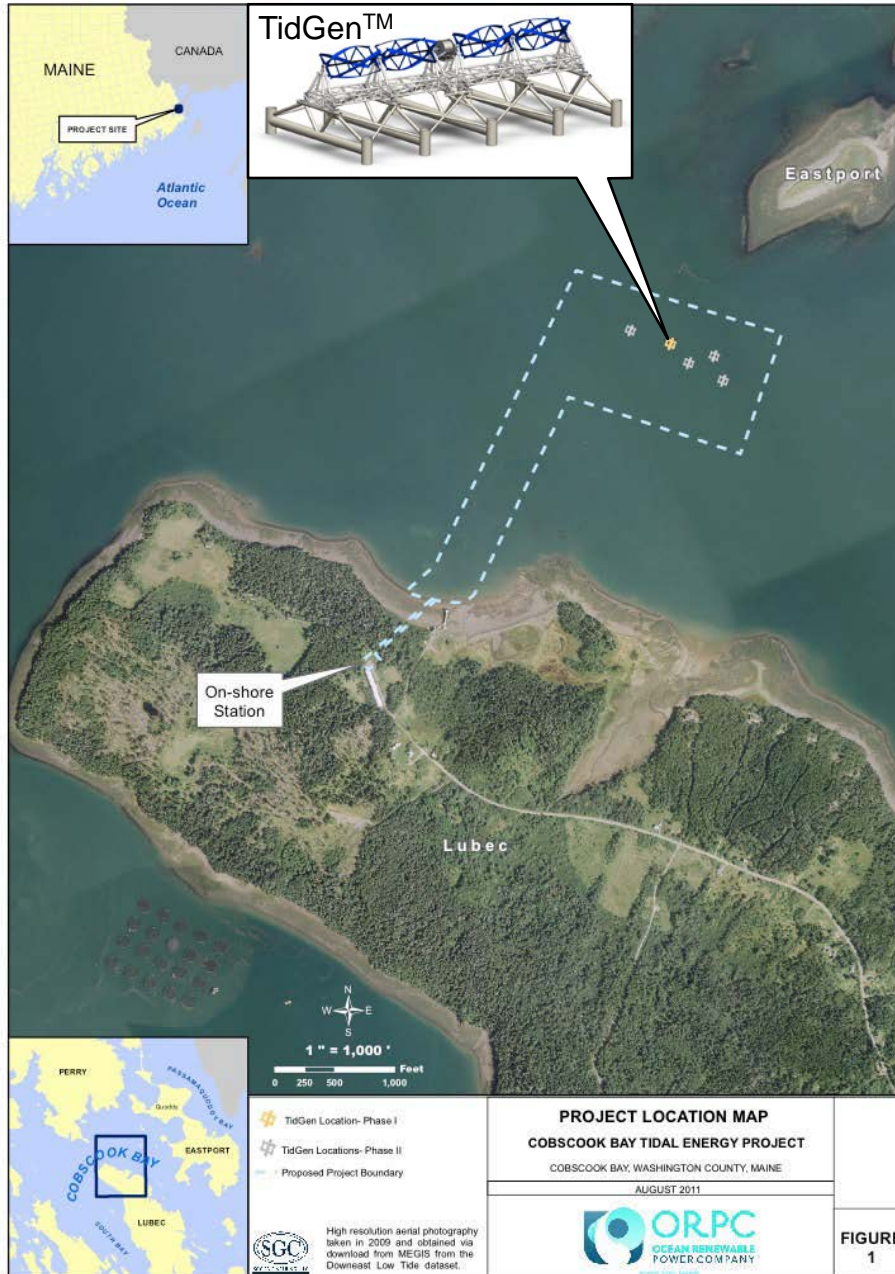

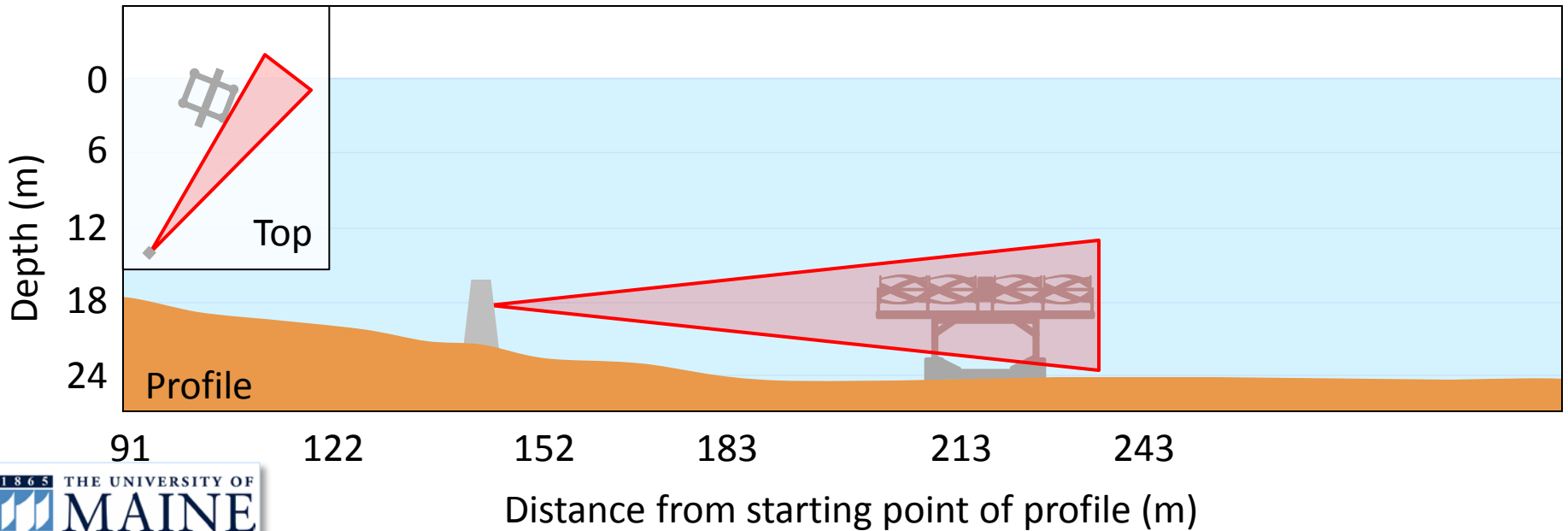
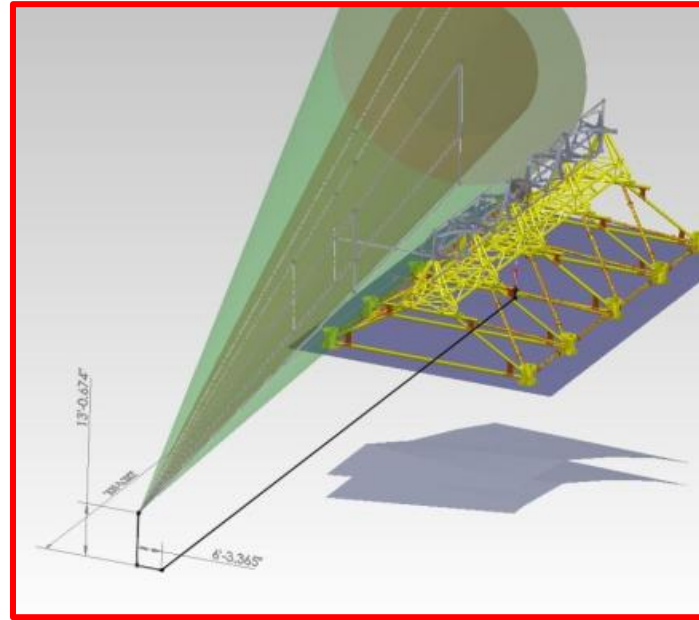
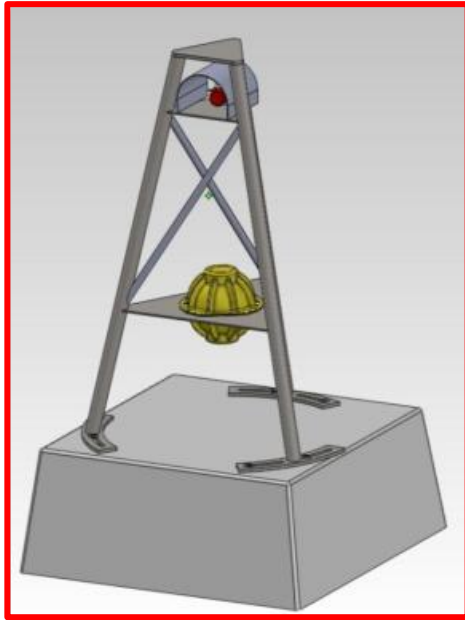

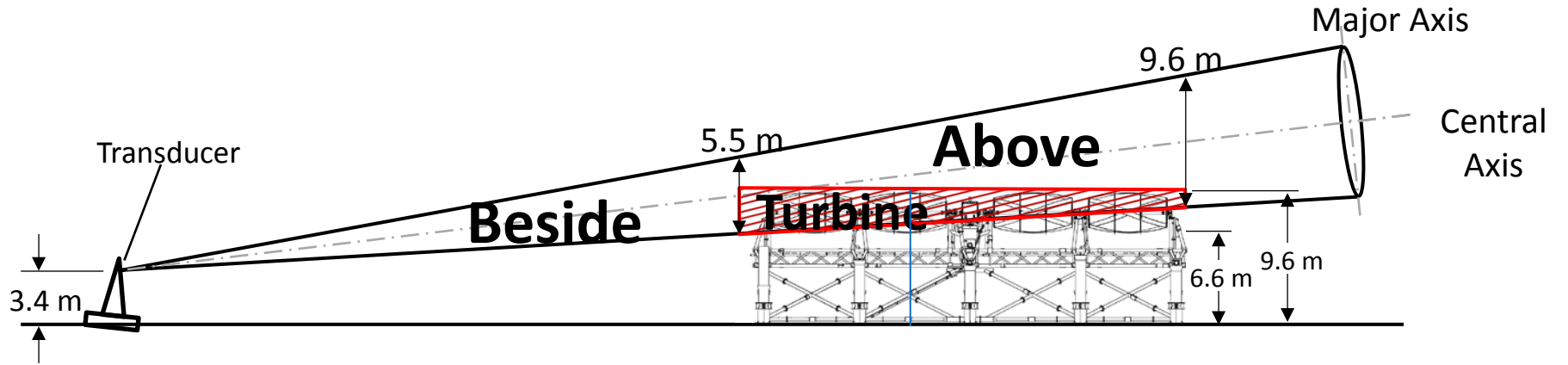

Types of Data: Horizontal Movement

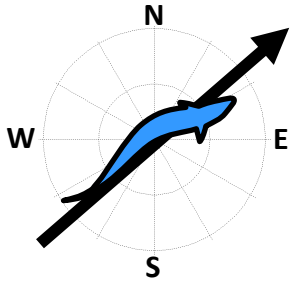
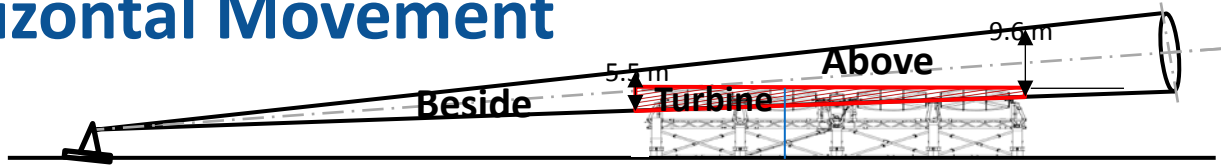

Beside

Above

Turbine

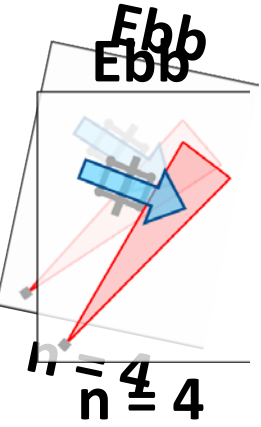
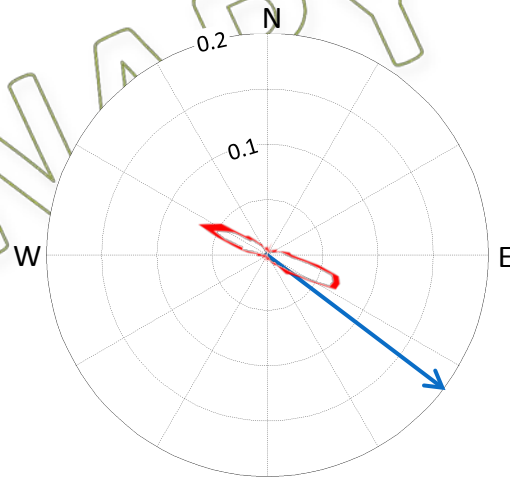
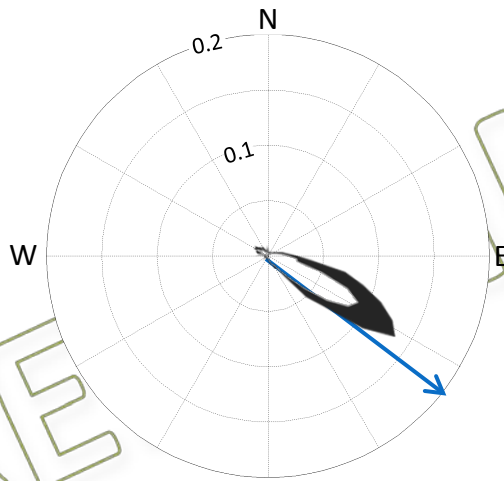
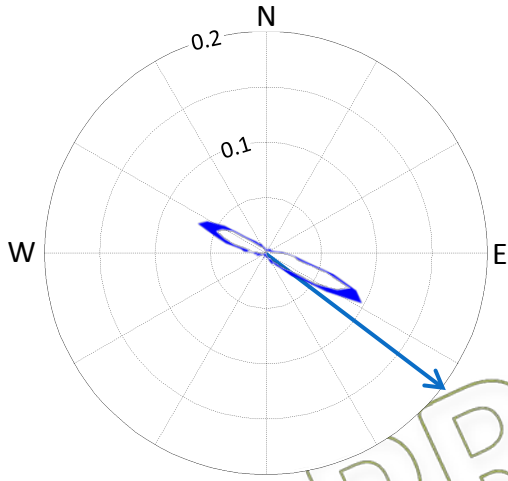

Flood

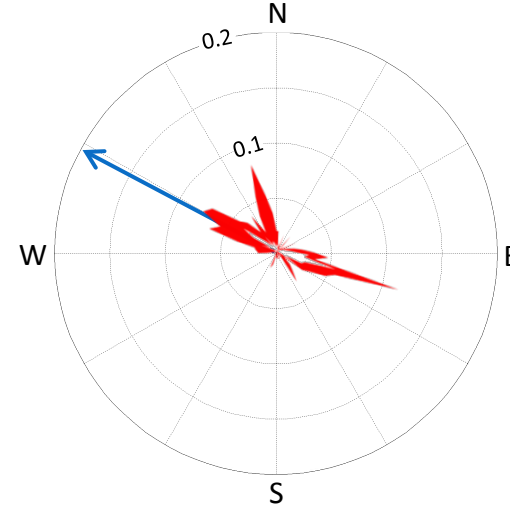
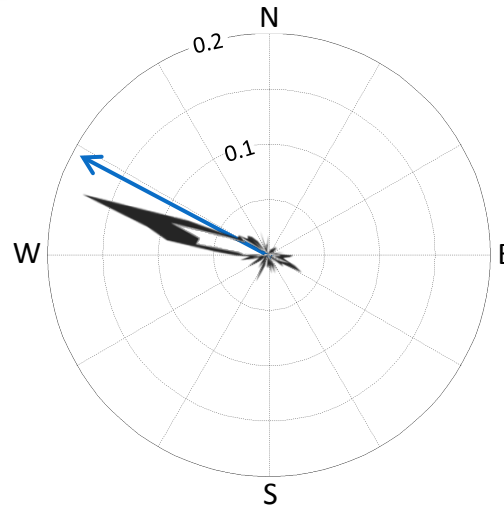
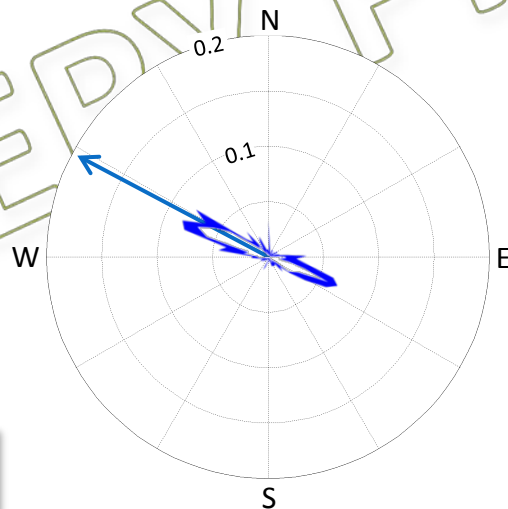

n = 3

Broad scale changes in distribution and abundance

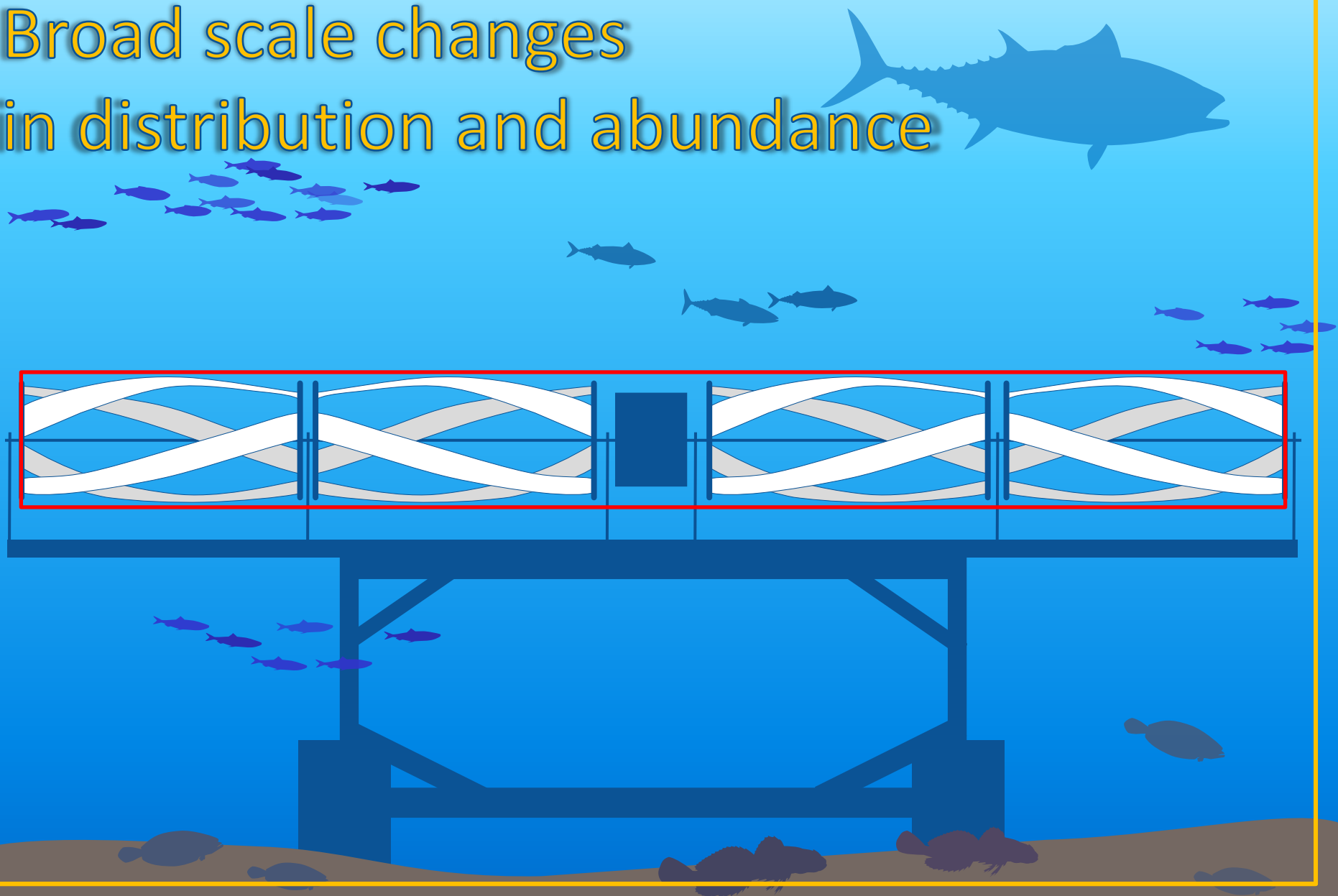

Broad Scale: Study Design

- Wide-angle, single-beam echosounder
- Before-After-Control-Impact

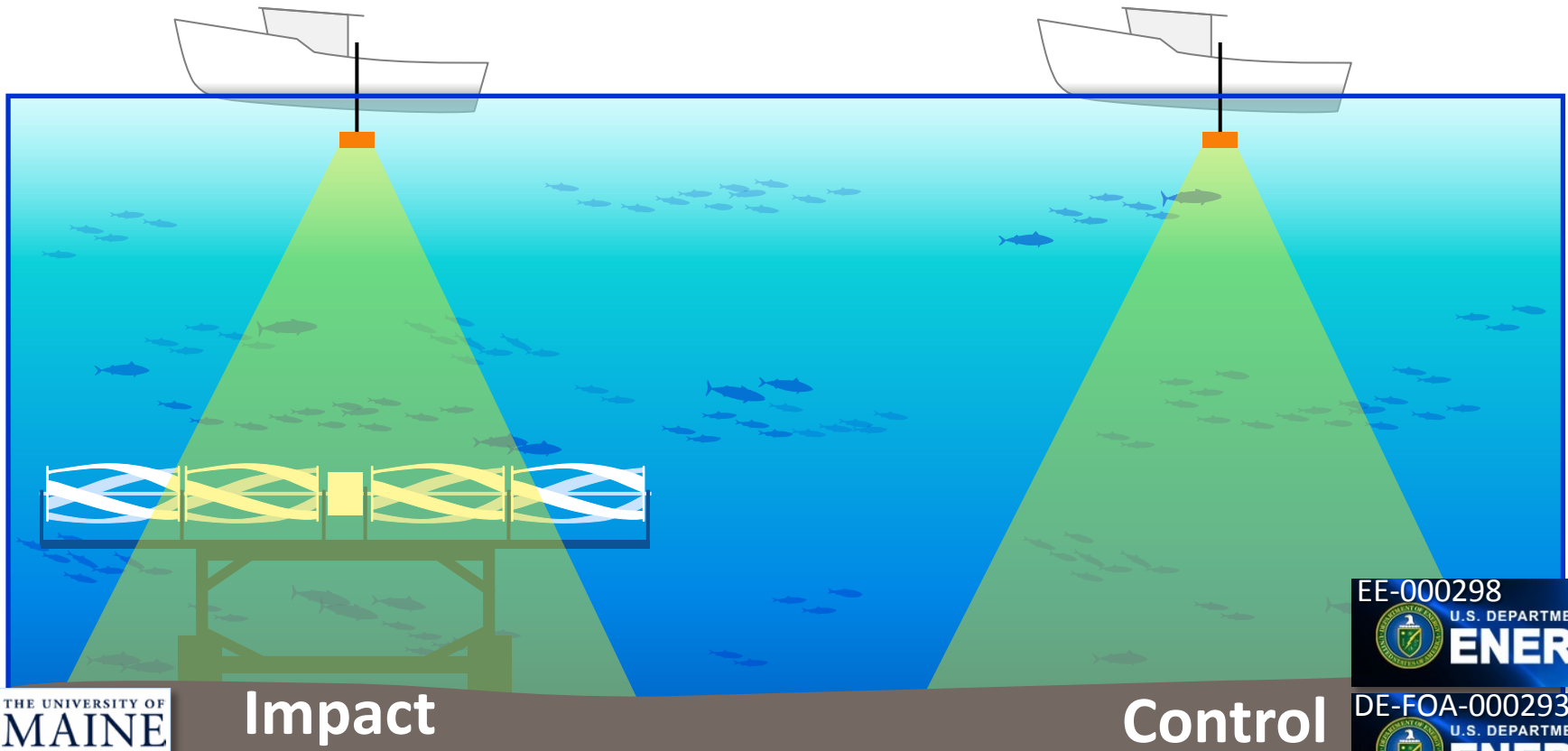

Impact

Control

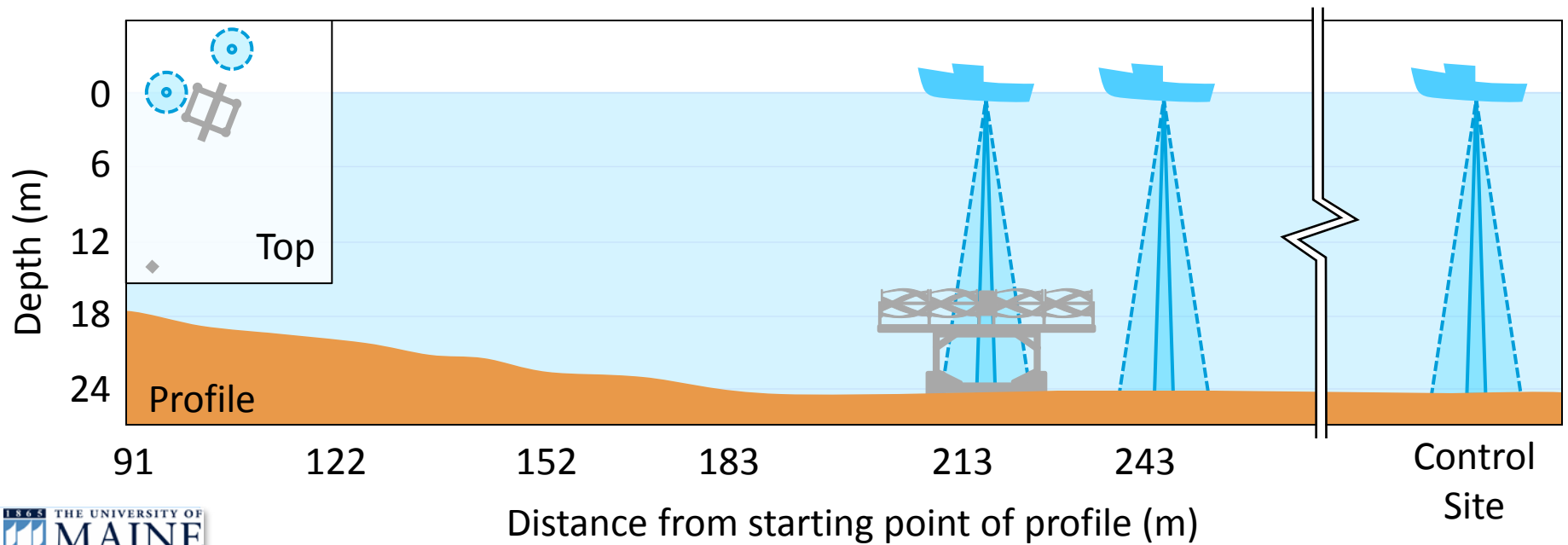
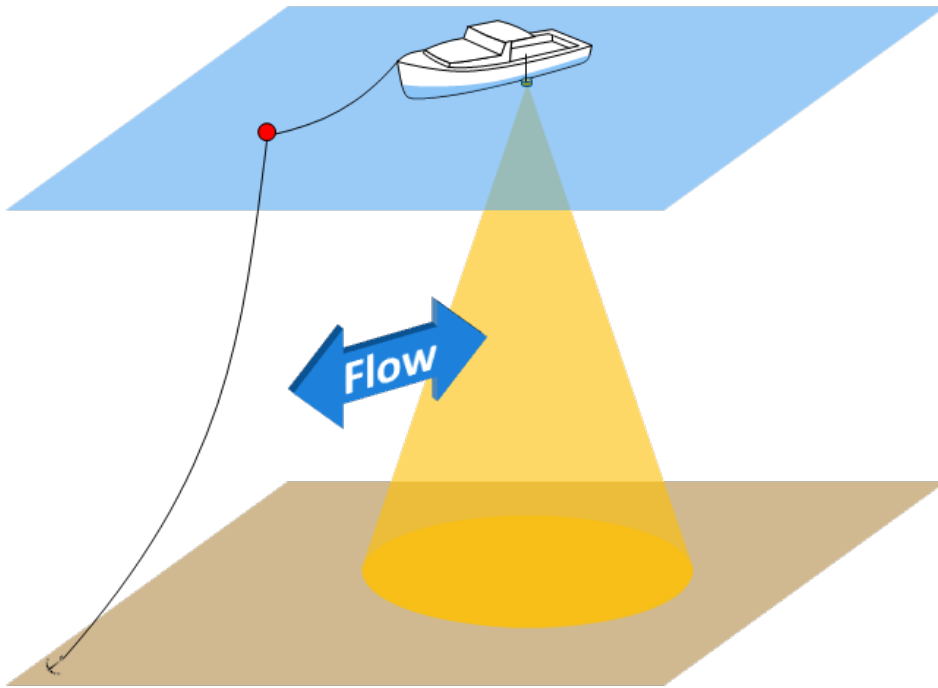

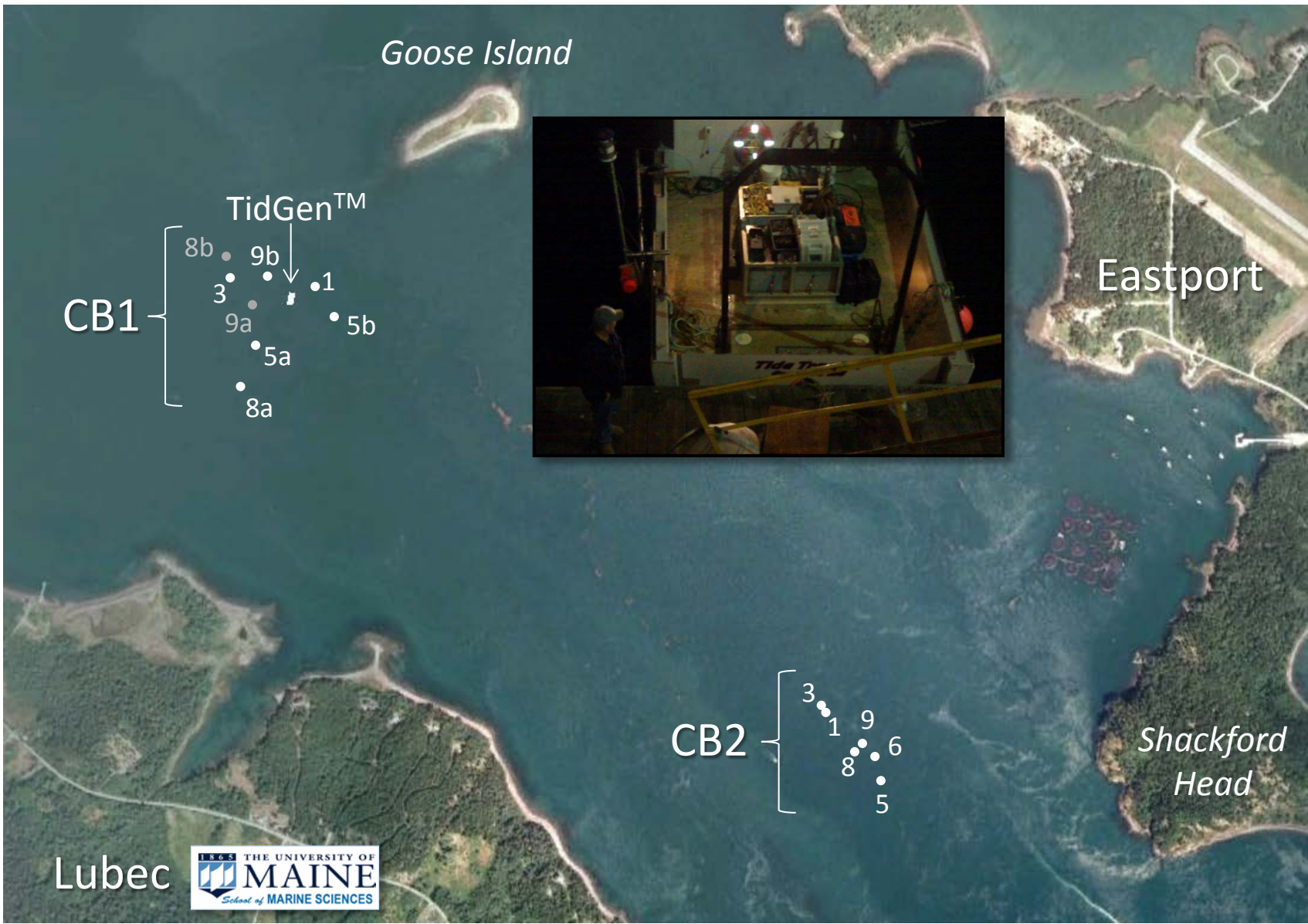

Year	Jan	Feb	Mar	April	May	June	July	Aug	Sept	Oct	Nov	Dec
2010					1, 2			1, 2	1, 2	1, 2	1, 2	
2011			1, 2		1, 2	1, 2		1, 2	1, 2		1, 2	
2012	1, 2		1, 2		1a, 1b, 2	2		1a, 1b, 2	1a, 1b, 2			

Vertical Distribution

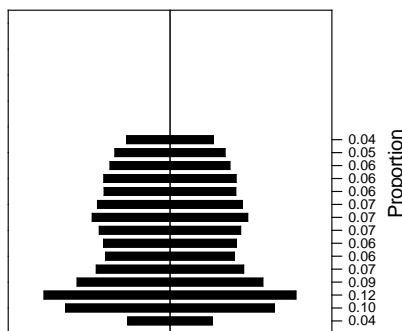
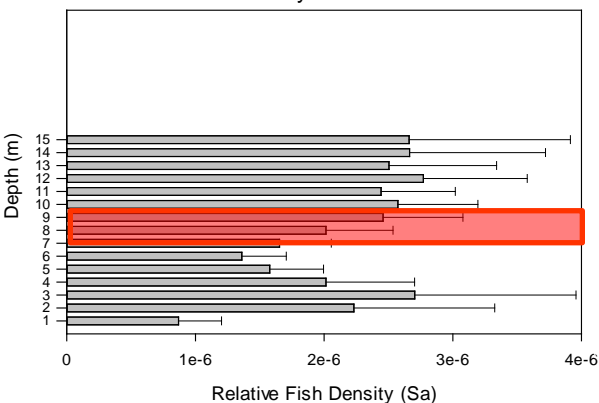
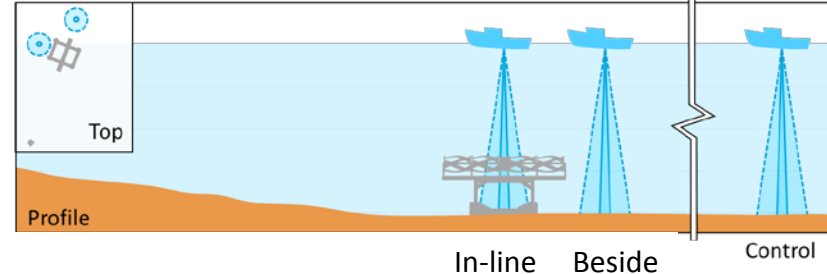

May 2012
'Beside'

May 2012
'In-line'

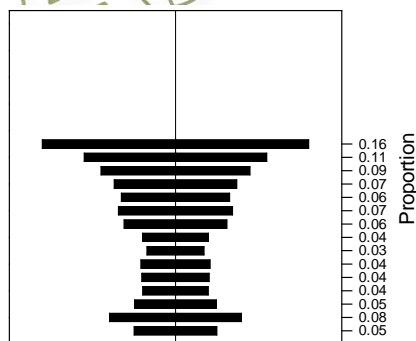
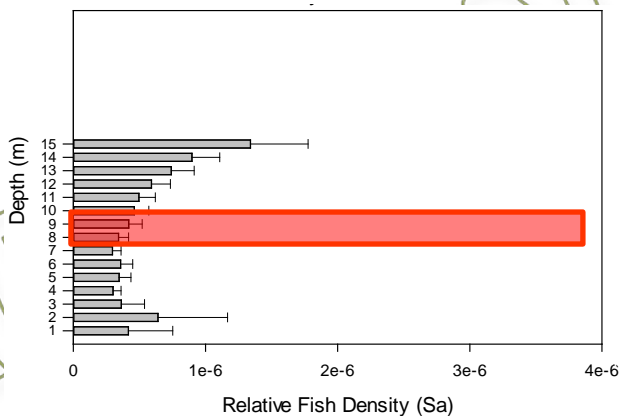

May
Control

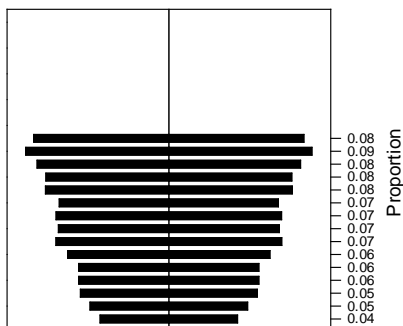
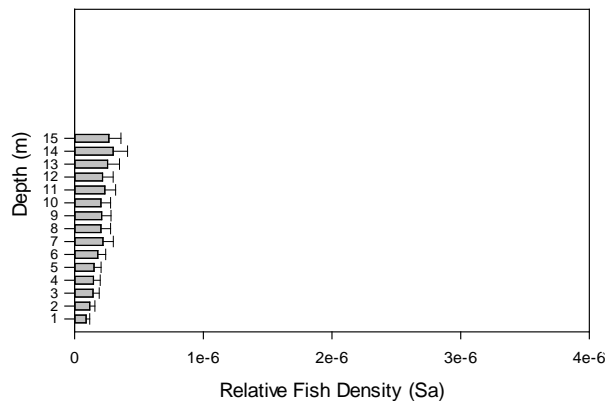

PRELIMINARY

PRELIMINARY

Site Abundance (relative density)

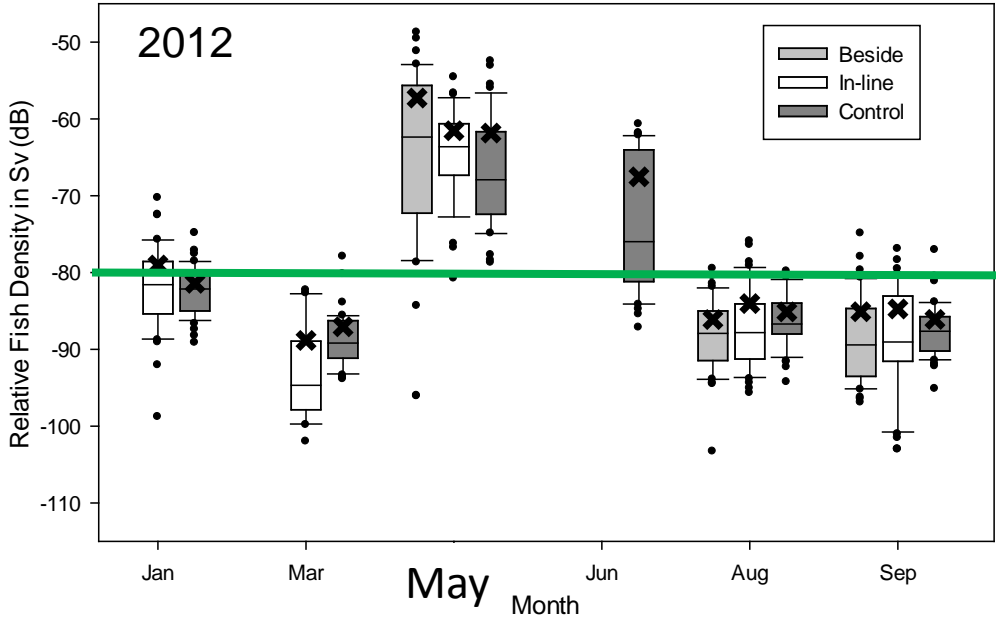
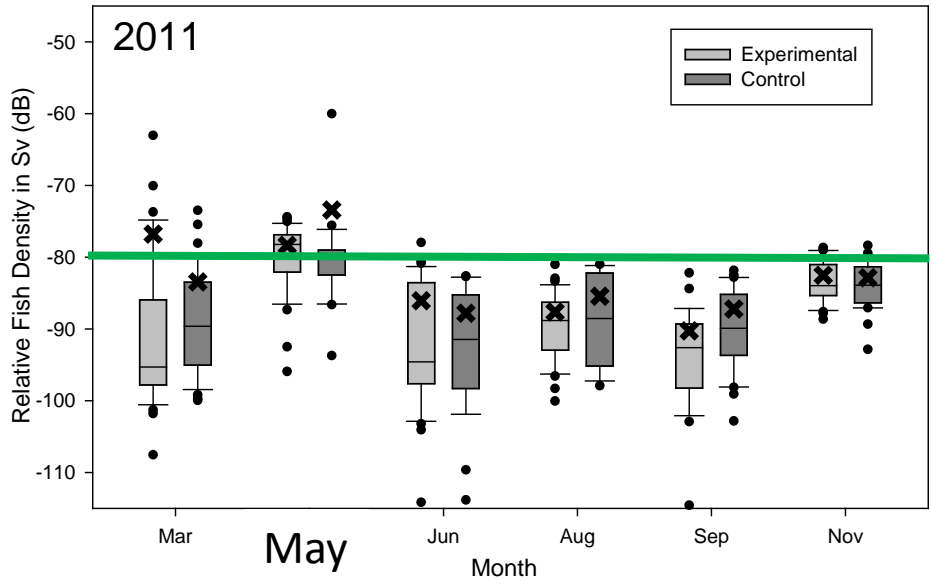
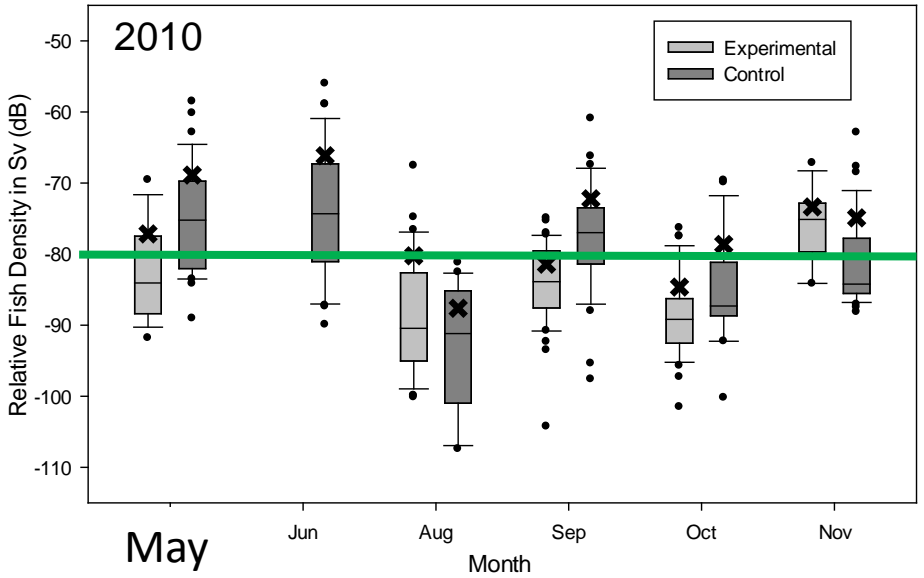

EVEN BroadER scale



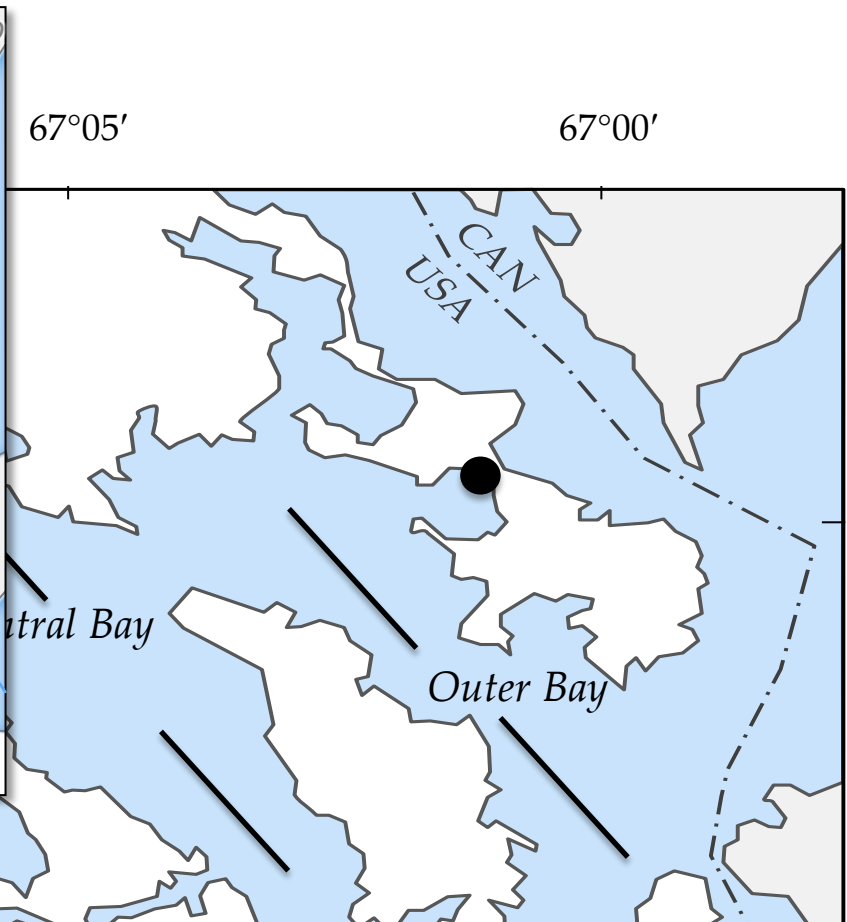
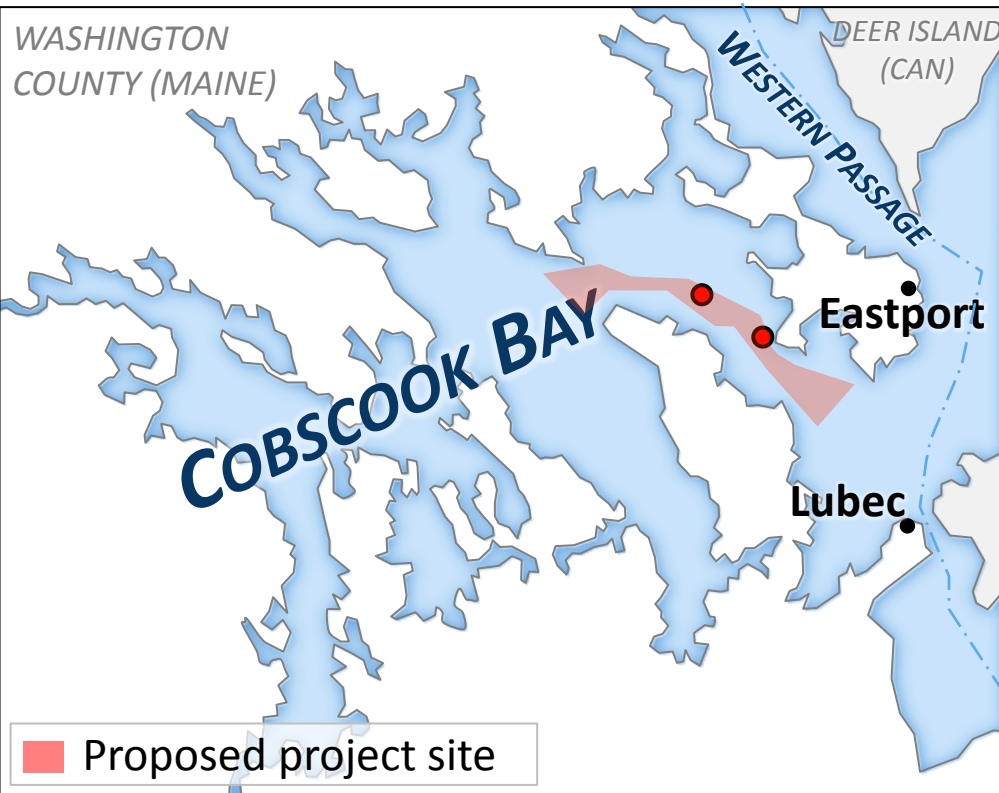

Fish interaction with ORPC TidGen™ in Cobscook Bay

Gayle Zydlewski, University of Maine



Development of an ELAM Fish Behavior Model

Gayle Zydlewski, University of Maine

Mark Grippo, Argonne National Laboratory



Environmental Science Division (EVS)

Advancing informed environmental decision making

Individual evasion/avoidance

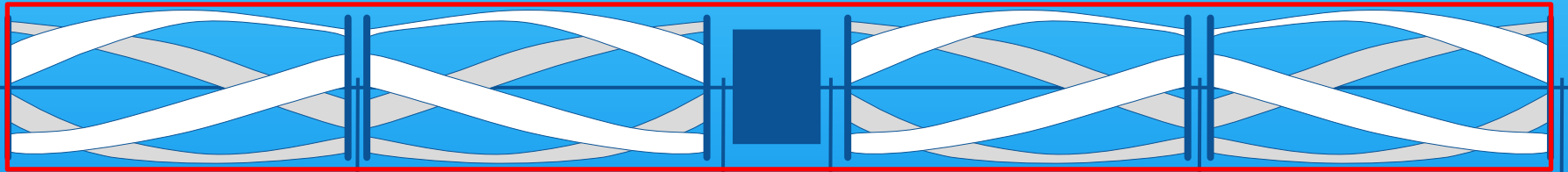

Mobile Hydroacoustics

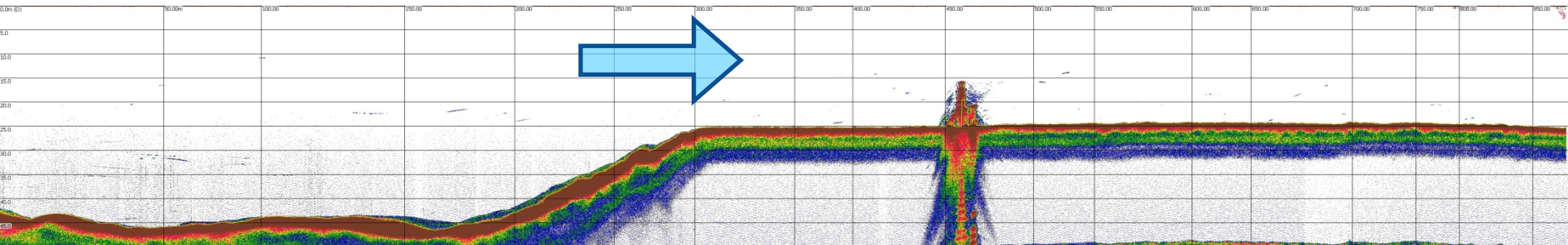
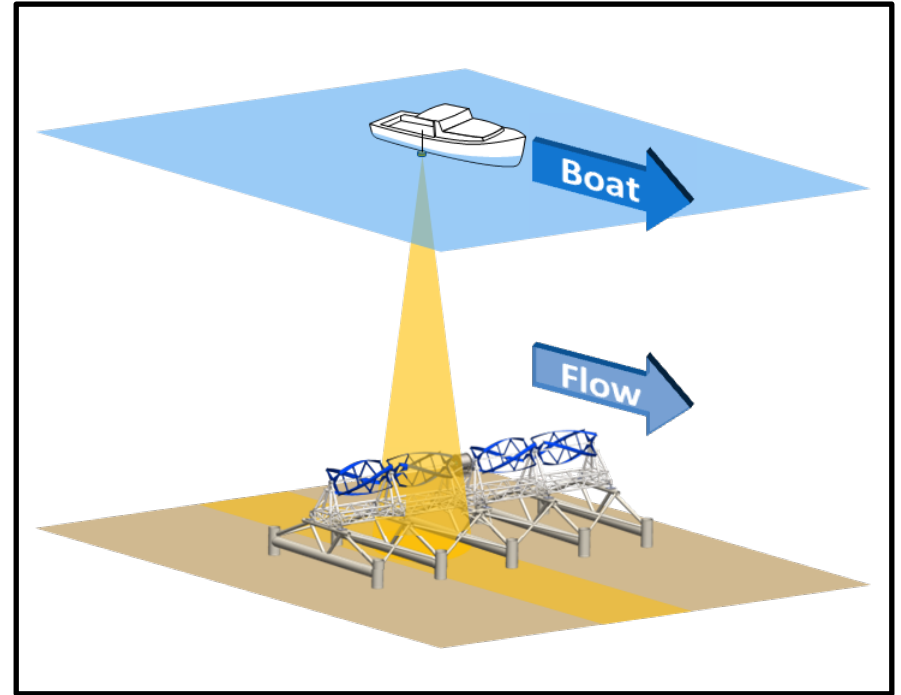
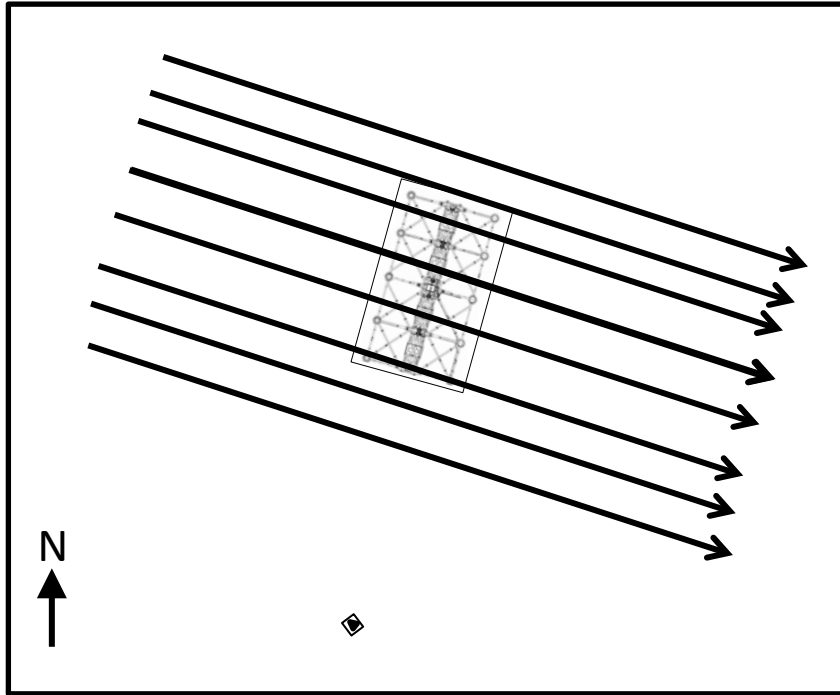

Behavioral Change Points - Avoidance and Evasion

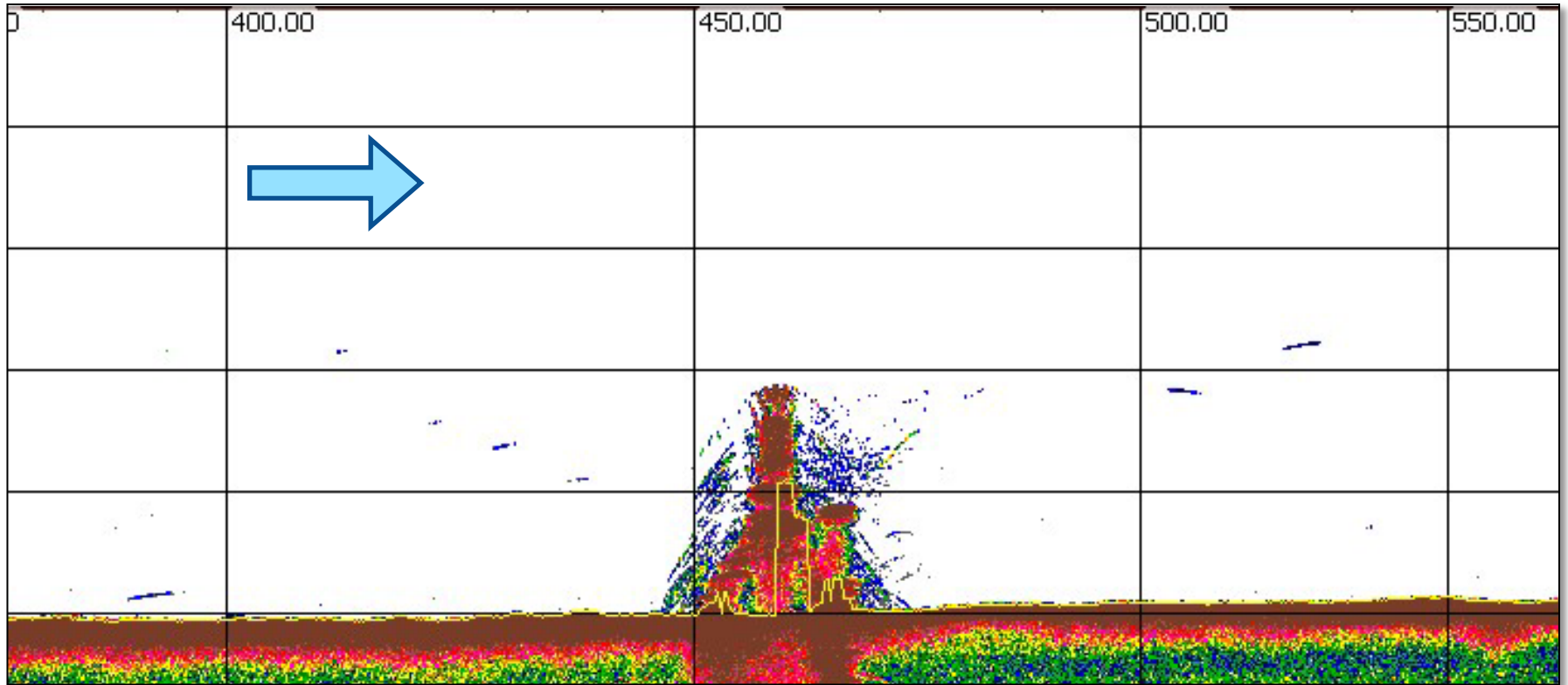

USE OF ELAM to Assess Behavioral Risks Associated with an MHK Turbine

M. Grippo
Environmental Science Division
Argonne National Laboratory

MHK Market Acceleration

The overall goal is to reduce the time and costs associated with siting and deploying MHK projects

Aid developers in meeting NEPA requirements by addressing concerns of regulatory and management agencies

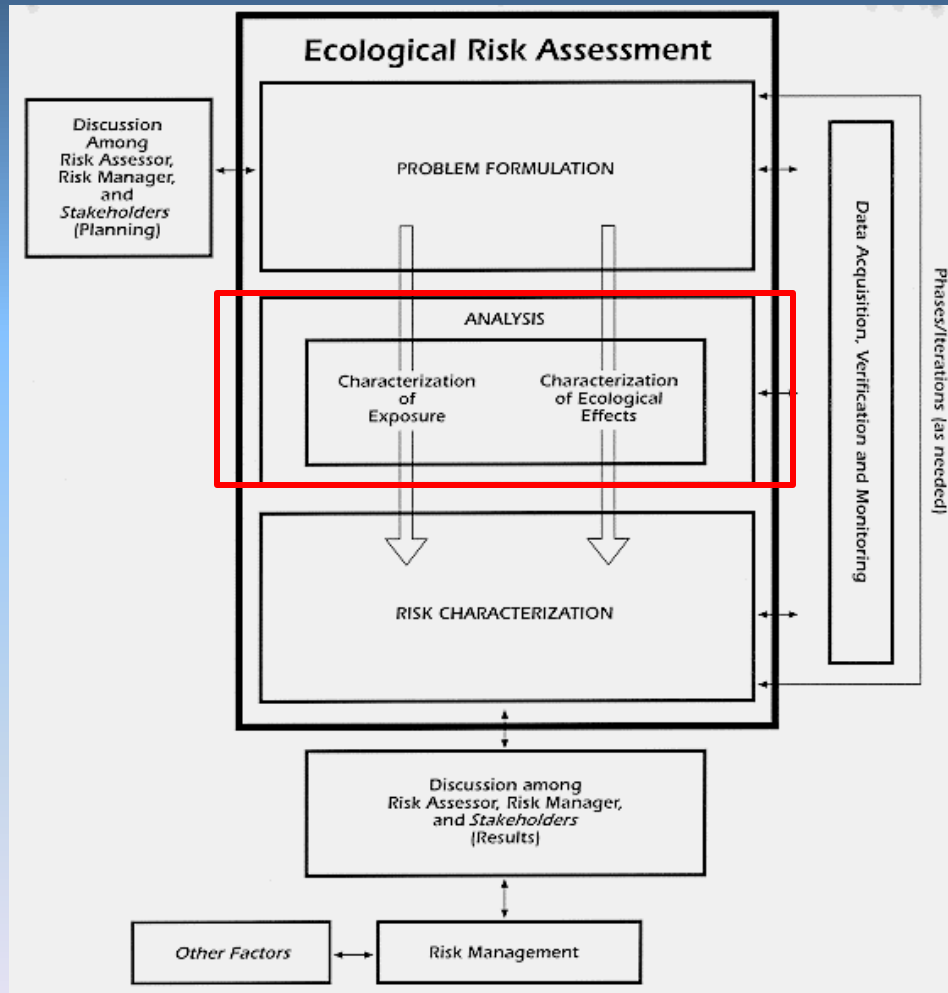

EPA RISK ASSESSMENT Analysis Phase

1. Characterization of Exposure

- Exposure of ecological receptors based on species life history and ecology

2. Characterization of Effects

- What are the effects of exposure

Source: Guidelines for Ecological Risk Assessment (EPA, 1998)

Behavioral Risk

Determining the behavioral responses of fish to MHK devices is critical to characterizing risk

- Avoidance or attraction
- Risk of blade strike
- Which species could be affected?
 - Migratory species
 - Structure oriented fish
- Do turbines occupy preferred habitat

Understanding Behavioral risk becomes even more important at full commercial build out



Mechanistic Behavior Models

- An attempt to understand the drivers of observed behavior
- Models animal movements based on various decision rules about how individual organisms respond to changing environmental variables.
- Allows one to forecast behavioral change under different environmental conditions

Mechanistic Behavior Models

Eulerian-Lagrangian-Agent Method (ELAM)

- The ELAM simulates fish behavior based primarily on hydrodynamic cues
- Developed by the US Army Corps of Engineers (USACE), Engineer Research and Development Center (ERDC; Goodwin et al. 2006)
- The ELAM has been applied to dam operations and fish bypass designs
- First application of the ELAM to MHK technology.

Method Overview

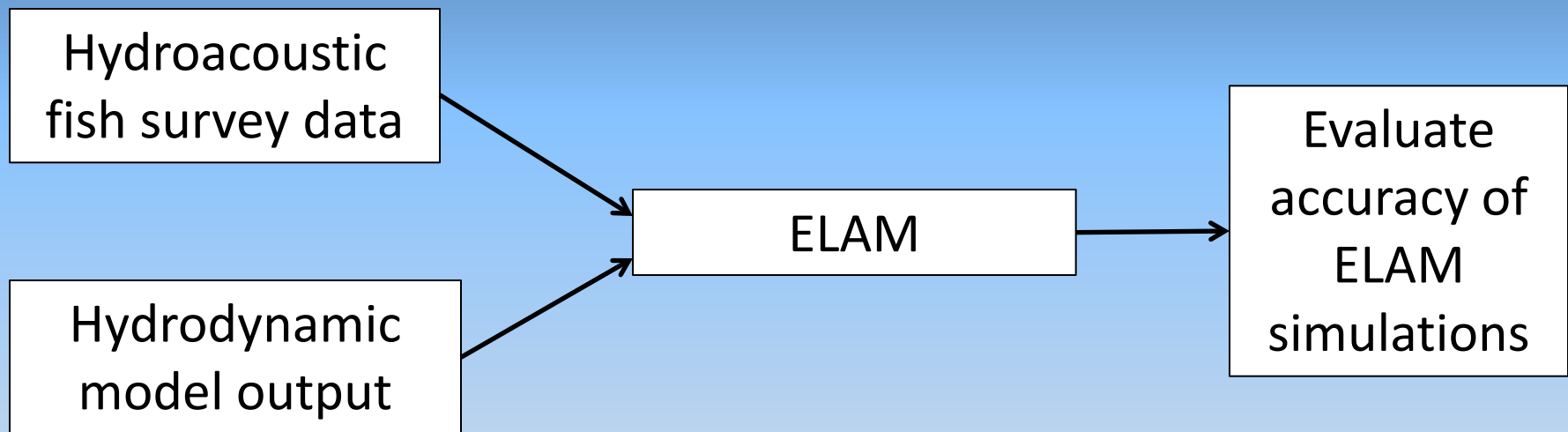

Hydrodynamic model development and initial mobile hydroacoustic surveys are ongoing

Completion by Fall 2014

Method

Hydrodynamic model development - Huijie Xue (UMaine)

- Increase spatial resolution of existing model to 1 m with 500 m upstream and downstream of the ORPC turbine
- Simulate hydrology for the time period corresponding to the mobile hydroacoustic survey

Hydrodynamic model development – Jesse Roberts (SNL)

- High resolution hydrodynamic model for Cobscook Bay using SNL-EFDC
- SNL-EFDC is used by ORPC and has wide familiarity within the MHK industry.

Method

Hydroacoustic fish data - Dr. Gayle Zydlewski (UMaine)

- Side-looking passive hydroacoustics data
- Mobile down-looking hydroacoustic drift surveys covering 100s of meters on either side of ORPC turbine
- Surveys conducted on flooding tide in spring and summer

Method

ELAM - Dr. Andrew Goodwin (US Army Engineer R&D Center)

- Synchronize the fish position data and the hydrodynamic model output
- Evaluate whether the ELAM simulates actual fish density and movement patterns more accurately than treating the fish as passive particles
- Refine to increase the correspondence between real-world fish data and ELAM model patterns

Ecological Risk Evaluation

- Place ELAM analysis results in an ecological risk context
 - characterization of exposure
 - inform the probability of blade strike
- Characterization of effects
 - Assess the nature and magnitude of movement changes
 - before and after encountering the ORPC turbine
 - with and without the turbines
- The analysis will include species specific evaluations



Potential Applications of the ELAM

- The modeled response of fish to a single MHK device would provide information on the potential responses of fish to an array of turbines
- Forecast fish responses to alternative turbine designs, turbine locations within the channel, and turbine configurations within an array
- Evaluate alternatives that may minimize impacts to fish movement behavior

Acknowledgements

Jocelyn Brown-Saracino
US Department of Energy

Hoyt Battey
US Department of Energy

Ocean Renewable Power Company